

# Cylinder Actuator for Knife Gate Valves

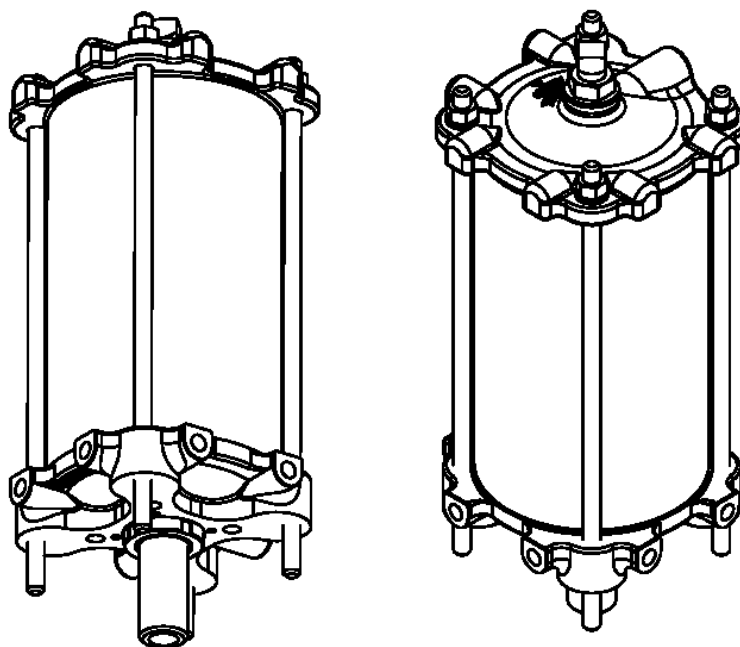

Instruction **D11066**  
April 2022

## Instructions

These instructions are for use by personnel who are responsible for the installation, operation and maintenance of DeZURIK valves, actuators or accessories.

## Safety Messages

All safety messages in the instructions are identified by a general warning sign and the signal word CAUTION, WARNING or DANGER. These messages indicate procedures to avoid injury or death.

Safety label(s) on the product indicate hazards that can cause injury or death. If a safety label becomes difficult to see or read, or if a label has been removed, please contact DeZURIK for replacement label(s).

---

### **⚠WARNING**

**Personnel involved in the installation or maintenance of valves should be constantly alert to potential emission of pipeline material and take appropriate safety precautions. Always wear suitable protection when dealing with hazardous pipeline materials. Handle valves which have been removed from service with suitable protection for any potential pipeline material in the valve.**

---

## Inspection

Your DeZURIK product has been packaged to provide protection during shipment; however, items can be damaged in transport. Carefully inspect the unit for damage upon arrival and file a claim with the carrier if damage is apparent.

## Parts

Replaceable wear parts are listed on the assembly drawing. These parts can be stocked to minimize downtime. Order parts from your local DeZURIK sales representative or directly from DeZURIK. When ordering parts please provide the following information:

**If the valve has a data plate:** please include the 7-digit part number with either 4-digit revision number (example: 9999999R000) or 8-digit serial number (example: S1900001) whichever is applicable. The data plate will be attached to the valve assembly. Also, include the part name, the assembly drawing number, the balloon number and the quantity stated on the assembly drawing.

**If there isn't any data plate visible on the valve:** please include valve model number, part name, and item number from the assembly drawing. You may contact your local DeZURIK Representative to help you identify your valve.

## DeZURIK Service

DeZURIK service personnel are available to maintain and repair all DeZURIK products. DeZURIK also offers customized training programs and consultation services. For more information, contact your local DeZURIK sales representative or visit our website at [DeZURIK.com](http://DeZURIK.com).

## Table of Contents

Description .....	4
Lubrication .....	4
Adjustments .....	4
Aligning the Cylinder .....	4
Valve Support.....	4
Cylinder Stroke Adjustment.....	5
Component Identification Drawing.....	6
Cartridge Rebuild.....	7
Disassembling the Cartridge .....	7
Reassembling the Cartridge.....	7
Cartridge Assembly Replacement .....	8
Cylinder Inspection .....	9
Disassembling the Cylinder.....	9
Reassembling the Cylinder .....	10
Troubleshooting .....	11

## Description

The cylinder used with DeZURIK Knife Gate Valves is a pneumatic double-acting cylinder that has a recommended supply pressure between 60 and 100 psi. Cylinder pressure should never exceed 100 psi. Cylinder can operate at less than 60 psi when valve thrust requirements allow. Use proper cylinder sizing to determine operating pressure.

### ⚠ WARNING

**This cylinder is a pressure vessel. Pressure in the cylinders can cause personal injury or equipment damage. Release pressure from both ends of the cylinder before servicing.**

## Lubrication

The cylinder only requires lubrication when reassembling a unit that has been disassembled. When reassembling, lubricate the Piston Seal (C11), Piston Wear Rings (C12), Piston (C10) grooves and inside wall of Cylinder Tube (C13) with Dow Corning No. 44 lubricant, or for cylinders that are for -40°F to -58°F (-40°C to -50°C) environments, lubricate with Dow Corning No. 55 lubricant.

## Adjustments

### Aligning the Cylinder

To work properly, the Piston Rod (C14) and gate must be aligned. The mounting holes in the cylinder and yoke are designed to allow for adjustment. Visually check the alignment with the valve in the open and close positions, and adjust as needed.

1. Align the Piston Rod (C14) and the gate with each other.
2. Check the Piston Rod (C14) and gate alignment in the valve open and closed positions.
3. Adjust the cylinder position if needed.

**Note:** Oversized mounting holes in the cylinder and yoke allow for adjustment.

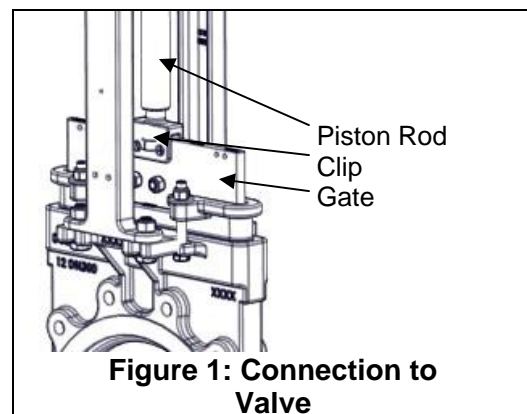

### Valve Support

The valve may be mounted in any position around the pipeline, however it is best to mount the valve with the cylinder in a vertical position. If the valve is installed with the cylinder in a position other than vertical, the customer must provide support on valves that are 8 inches and larger. Support can be provided on the outer surfaces of the legs, close to the cylinder. See the installation drawing for dimension location of the support.

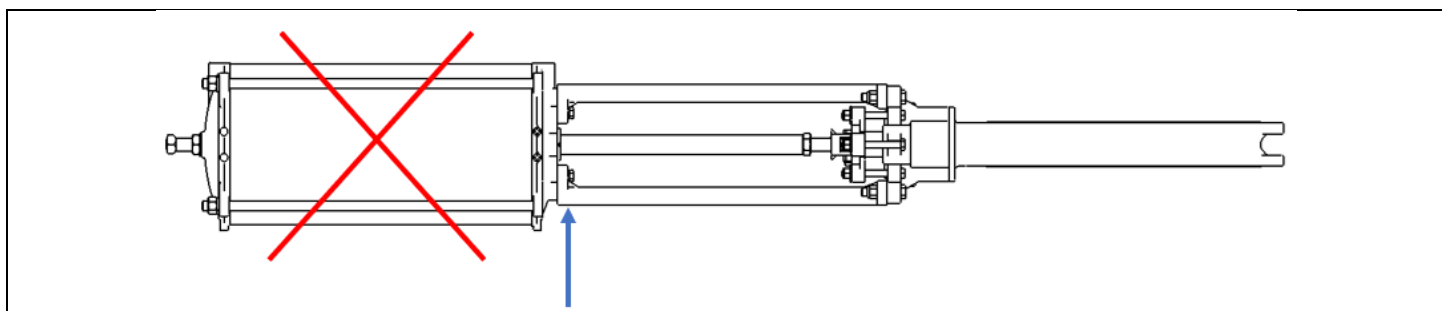

**NOTICE**

Do not mount supports on the Cylinder Tube (C13).

---

***Cylinder Stroke Adjustment***

The Adjusting Screw (C21) in the cylinder acts as the cylinder stroke adjustment. Adjust the screw so that the actuator does not pull the gate off the seat ring when the valve is fully opened.

To adjust the closed position:

1. Close the valve.
2. Turn the clip into the piston rod (C14) until the cylinder has a minimum of 1/16" stroke remaining and tighten jam nut.
3. Open the valve and adjust the adjusting screw (C21) until the gate is clear of the flow port but fully on the seat ring. Tighten Jam nut (C22).

## Component Identification Drawing

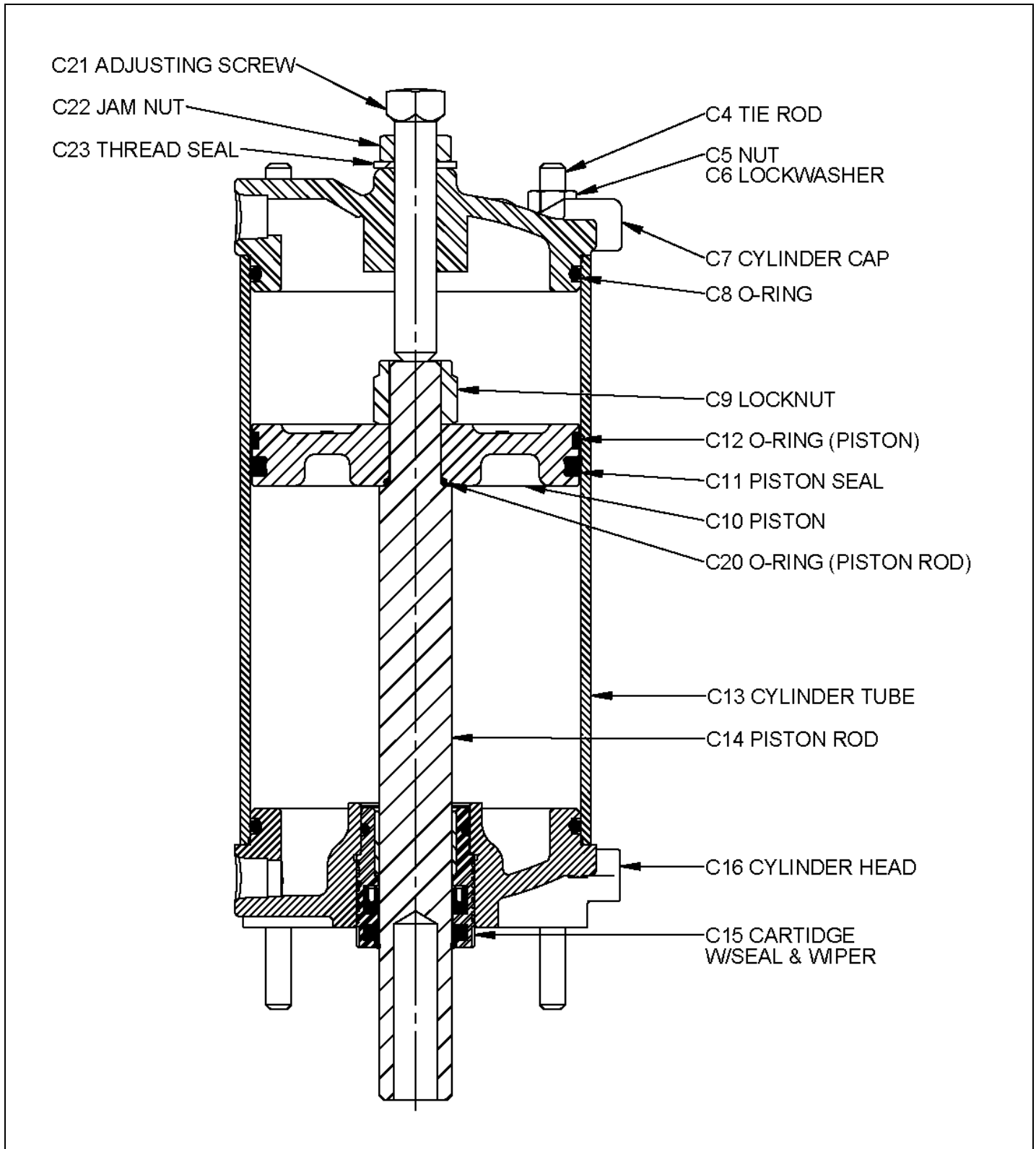

Figure 3: Component Identification

## Cartridge Rebuild

To repair a cylinder actuator with the rod seal and wiper damaged by outside contaminants on the piston rod (C14) during the retracting stroke.

---

**▲WARNING**

**This cylinder is a pressure-containing vessel! Removing any parts while under pressure could cause personal injury or equipment damage. Release the pressure from both ends of the cylinder before attempting disassembly or repair.**

---

See Figure 4. The Rod U Cup Seal (C15C) and Rod Wiper Seal (C15B) are installed in the Cartridge (C15A), along with an O-ring (C15D).

### ***Disassembling the Cartridge***

1. Shut off the air supply
2. Remove the Cylinder Cartridge (C15A) by unscrewing it from the Cylinder Head (C16) with a spanner wrench.
3. Once Cylinder Cartridge (C15A) is threaded free from the Cylinder Head (C16), slide Cylinder Cartridge (C15A) all the way down the Piston Rod (C14) and off.
4. Remove the Rod Wiper Seal (C15B), Rod U Cup Seal (C15C) and O-ring (C15D) from the Cylinder Cartridge (C15A).

### ***Reassembling the Cartridge***

1. Clean the Cylinder Cartridge (C15A) grooves and lubricate with Dow Corning Number 44 lubricant, or Dow Corning Number 55 in cylinders for -40°F to -58°F (-40°C to -50°C)° service.
2. Insert the Rod U Cup Seal (C15C) into its groove, with the cup facing inwards similar to Figure 4.
3. Insert Rod Wiper Seal (C15B) into its groove.
4. Place O-ring (C15D) into its outer groove.
5. Carefully slide assembled Cylinder Cartridge (C15A), in proper orientation, onto Piston Rod (C14) and screw Cylinder Cartridge (C15A) into the Cylinder Head (C16).
6. Mount cylinder onto valve and perform cylinder stroke adjustment as needed.

## Cartridge Assembly Replacement

**⚠WARNING**

This cylinder is a pressure-containing vessel! Removing any parts while under pressure could cause personal injury or equipment damage. Release the pressure from both ends of the cylinder before attempting disassembly or repair.

1. To replace the Cylinder Cartridge Assembly (C15) shut off the air supply.
2. Remove the Cylinder Cartridge Assembly (C15) by unscrewing it from the Cylinder Head (C16) with a spanner wrench.
3. Once Cylinder Cartridge Assembly (C15) is threaded free from the Cylinder Head (C16), slide Cylinder Cartridge Assembly (C15) all the way down the Piston Rod (C14) and off.
4. Replace it with a new Cylinder Cartridge Assembly (C15).

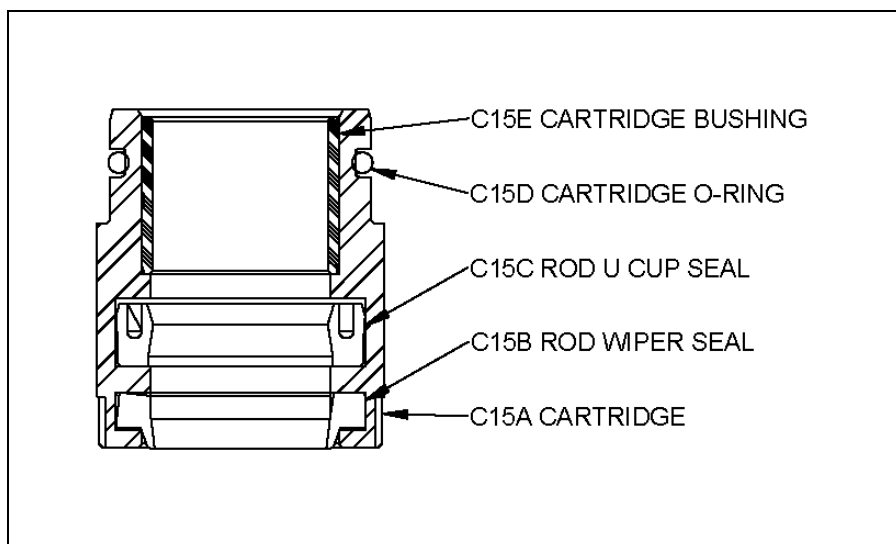

Figure 4: Cartridge Assembly (C15)



## Cylinder Inspection

### ⚠ WARNING

This cylinder is a pressure-containing vessel! Removing any parts while under pressure could cause personal injury or equipment damage. Release the pressure from both ends of the cylinder before attempting disassembly or repair.

### Disassembling the Cylinder

1. Shut off the air/fluid supply to the cylinder and relieve pipeline and cylinder pressure.
2. Disconnect the air supply lines

**Note:** When flexible tubing is used, only one swivel connector is used on each piece of tubing. The swivel connector is located on the end of the tubing attached to the cylinder port.

3. Remove the Nuts (C5) and Washers (C6) from the Tie-Rods (C4).
4. Remove the Cylinder Cap (C7) and remove the O-ring (C8) from the Cylinder Cap (C7).
5. Remove the Cylinder Tube (C13), Piston Seal (C11) and Piston Wear Ring (C12). Clean the parts and the grooves in the Piston (C10). See Figure 5.

**Note:** Rotating the Cylinder Tube (C13) while pulling makes it easier to get it off the Piston (C10).

6. Remove the Piston Rod (C14) assembly and remove the O-ring (C8) from the Cylinder Head (C16).
7. Remove Cylinder Cartridge Assembly (C15). Use a spanner wrench to unscrew the Cylinder Cartridge Assembly (C15) out of the Cylinder Head (C16). See Figure 6.
8. Clean all parts thoroughly. Replace damaged parts.

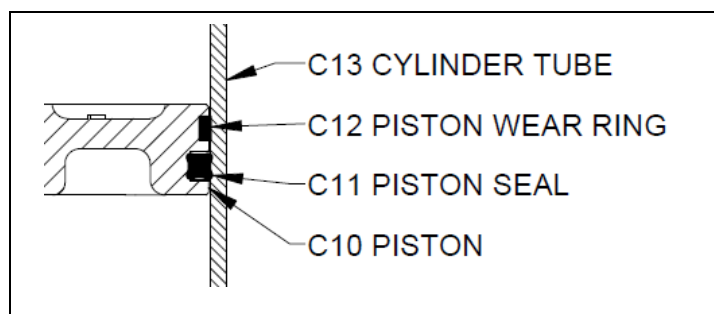

Figure 5 – Piston Seal

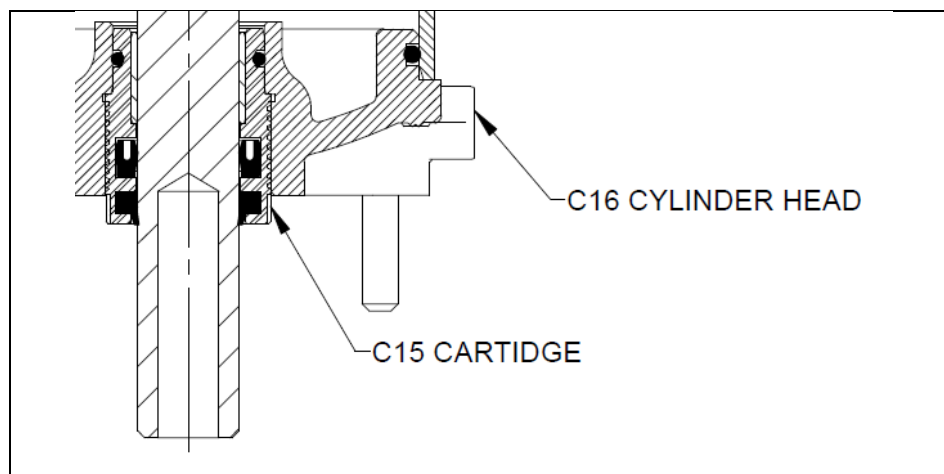
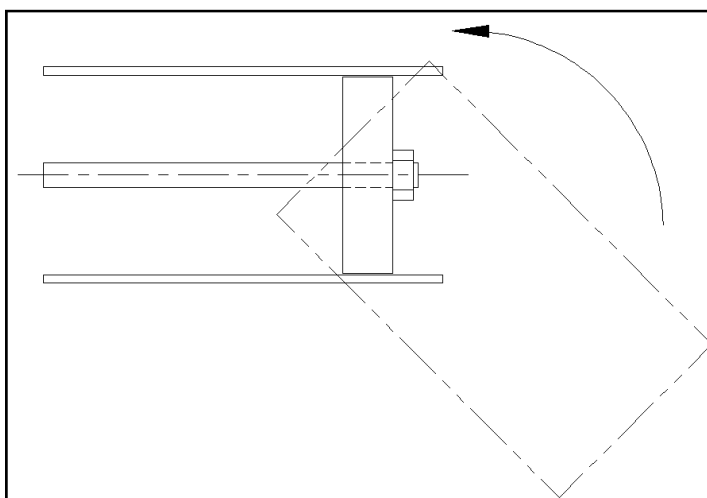

Figure 6 – Cylinder Head and Cartridge

**Reassembling the Cylinder**

1. Clean bore of Cylinder Head (C16) and lubricate with Dow Corning Number 44 lubricant, or Dow Corning Number 55 on cylinders used in  $-40^{\circ}\text{F}$  to  $-58^{\circ}\text{F}$  ( $-40^{\circ}\text{C}$  to  $-50^{\circ}\text{C}$ ) service.
2. Lubricate the O-ring (C8) and place it on the Cylinder Head (C16).
3. Clean and thread in Cylinder Cartridge (C15) in to the Cylinder Head (C16).
4. Carefully install the Piston Rod (C14).
5. Lubricate the Piston Seal (C11), Piston Wear Ring (C12) and cylinder groove with Dow Corning Number 44 lubricant and place the Piston Seal (C11) and Piston Wear Ring (C12) on the Piston (C10). For cylinders for  $-40^{\circ}\text{F}$  to  $-58^{\circ}\text{F}$  ( $-40^{\circ}\text{C}$  to  $-50^{\circ}\text{C}$ ) service applications, a Piston Seal (C11) is not used and Dow Corning No. 55 lubricant should be applied.
6. Carefully slide the Cylinder Tube (C13) over the Piston (C10). The Piston Seal (C11) must be well lubricated. Start the Cylinder Tube (C13) at a  $45^{\circ}$  angle and rotate it into position onto the Piston (C10). See Figure 7.
7. Lubricate the O-ring (C8) and place it on the Cylinder Cap (C7).
8. Place the Cylinder Cap (C7) on the Cylinder Tube (C13) and place the Washers (C6) and Nuts (C5) on the Tie-Rods (C4). Tighten the Nuts (C5) to the torque listed in Table A.

**Figure 7—Assembling Cylinder**

## Troubleshooting

<i>Condition</i>		<i>Possible Cause</i>	<i>Corrective Action</i>
External Leakage	Cartridge leak	Worn or damaged piston rod or cartridge	Replace piston rod if surface is rough Replace piston rod and rebuild or replace cartridge if worn
		Cylinder tube seal leak	Loose tie rods
	Excessive pressure		Reduce pressure below maximum pressure of 100 psi
	Damaged O-rings	Replace O-rings and torque tie rod nuts. See Table A	
Internal Leakage	Piston seal leakage	Piston seal wear	Replace seal O-ring as required
		Cylinder drifts	Pressurize one side of the cylinder piston and disconnect air/fluid line at opposite port. If no leakage, find cause of cylinder drift in other component parts in the circuit
Cylinder Fails to Move the Load	Pressure is too low		Check pressure at cylinder, make sure it is to circuit requirements
	Piston seal leakage		Cycle cylinder by operating the valve, watch air flow at valve exhaust ports at end of cylinder stroke. Replace piston seals if flow is excessive.
	Cylinder is undersized for the load		Replace cylinder with one of a larger bore size
	Piston rod broken		Contact your local DeZURIK representative to order new piston rod
Erratic or Chatter Operation	Load misalignment, excessive friction at cartridge or piston		Correct alignment of cylinder to load
	Load requirements are too closely sized to cylinder		Install larger cylinder
	Static and kinetic friction		Install speed control valves to provide back pressure for controlling stroke

## Limited Warranty

DeZURIK, Inc. ("Seller") manufactured products, auxiliaries and parts thereof that we manufacture for a period of twenty-four (24) months from date of shipment from Seller's factory, are warranted to the original purchaser only against defective workmanship and material, but only if properly stored, installed, operated, and serviced in accordance with Seller's recommendations and instructions.

For items proven to be defective within the warranty period, your exclusive remedy under this limited warranty is repair or replacement of the defective item, at Seller's option, FCA Incoterms 2020 Seller's facility with removal, transportation, and installation at your cost.

Products or parts manufactured by others but furnished by Seller are not covered by this limited warranty. Seller may provide repair or replacement for other's products or parts only to the extent provided in and honored by the original manufacturer's warranty to Seller, in each case subject to the limitations contained in the original manufacturer's warranty.

No claim for transportation, labor, or special or consequential damages or any other loss, cost or damage is being provided in this limited warranty. You shall be solely responsible for determining suitability for use and in no event shall Seller be liable in this respect.

This limited warranty does not warrant that any Seller product or part is resistant to corrosion, erosion, abrasion or other sources of failure, nor does Seller warrant a minimum length of service.

Your failure to give written notice to us of any alleged defect under this warranty within twenty (20) days of its discovery, or attempts by someone other than Seller or its authorized representatives to remedy the alleged defects therein, or failure to return product or parts for repair or replacement as herein provided, or failure to store, install, or operate said products and parts according to the recommendations and instructions furnished by Seller shall be a waiver by you of all rights under this limited warranty.

This limited warranty is voided by any misuse, modification, abuse or alteration of Seller's product or part, accident, fire, flood or other Act of God, or your failure to pay entire contract price when due.

The foregoing limited warranty shall be null and void if, after shipment from our factory, the item is modified in any way or a component of another manufacturer, such as but not limited to; an actuator is attached to the item by anyone other than a Seller factory authorized service personnel.

All orders accepted shall be deemed accepted subject to this limited warranty, which shall be exclusive of any other or previous warranty, and this shall be the only effective guarantee or warranty binding on Seller, despite anything to the contrary contained in the purchase order or represented by any agent or employee of Seller in writing or otherwise, notwithstanding, including but not limited to implied warranties.

THE FOREGOING REPAIR AND REPLACEMENT LIMITED WARRANTY IS IN LIEU OF ALL OTHER WARRANTIES, OBLIGATIONS AND LIABILITIES, INCLUDING, BUT NOT LIMITED TO, ALL WARRANTIES OF FITNESS FOR A PARTICULAR PURPOSE OR OF MERCHANTABILITY OR OTHERWISE, EXPRESSED OR IMPLIED IN FACT OR BY LAW, AND STATE SELLER'S ENTIRE AND EXCLUSIVE LIABILITY AND YOUR EXCLUSIVE REMEDY FOR ANY CLAIM IN CONNECTION WITH THE SALE AND FURNISHING OF SERVICES, GOODS OR PARTS, THEIR DESIGN, SUITABILITY FOR USE, INSTALLATION OR OPERATIONS. NEITHER ANY PERFORMANCE OR OTHER CONDUCT, NOR ANY ORAL OR WRITTEN INFORMATION, STATEMENT, OR ADVICE PREPARED BY SELLER OR ANY OF OUR EMPLOYEES OR AGENTS WILL CREATE A WARRANTY, OR IN ANY WAY INCREASE THE SCOPE OR DURATION OF THE LIMITED WARRANTY.

## Disclaimer

Metric fasteners should not be used with ASME Class 150/300 bolt holes and flange bolt patterns. If you use metric fasteners with ASME Class 150/300 bolt holes and flange bolt patterns, it may lead to product failure, injury, and loss of life. DeZURIK Inc. disclaims all liability associated with the use of metric fasteners with ASME Class 150/300 bolt holes and flange patterns, including but not limited to personal injury, loss of life, loss of product, production time, equipment, property damage, lost profits, consequential damages of any kind and environment damage and/or cleanup. Use of metric fasteners with ASME Class 150/300 bolt holes and flange bolt patterns is a misuse that voids all warranties and contractual assurances. If you use metric fasteners with ASME Class 150/300 bolt holes and flange bolt patterns, you do so at your sole risk and any liability associated with such use shall not be the responsibility of DeZURIK, Inc. In addition to the foregoing, DeZURIK's Manufacturer's Conditions apply.

## Limitation of Liability

IN NO EVENT SHALL SELLER BE LIABLE FOR ANY DIRECT, INDIRECT, SPECIAL, PUNITIVE, EXEMPLARY, OR CONSEQUENTIAL DAMAGES (INCLUDING, BUT NOT LIMITED TO; DAMAGE TO OR LOSS OF OTHER PROPERTY OR EQUIPMENT, BUSINESS INTERRUPTION, COST OF SUBSTITUTE PRODUCTS, LOSS OF TIME, LOSS OF PROFITS OR REVENUE, COST OF CAPITAL, LOSS OF USE, OR DIMINUTION IN VALUE) WHATSOEVER, AND SELLER'S LIABILITY, UNDER NO CIRCUMSTANCES, WILL EXCEED THE CONTRACT PRICE FOR THE GOODS AND/OR SERVICES FOR WHICH LIABILITY IS CLAIMED. ANY ACTION FOR BREACH OF CONTRACT BY YOU, OTHER THAN RIGHTS RESPECTING OUR LIMITED WARRANTY DESCRIBED ABOVE, MUST BE COMMENCED WITHIN 12 MONTHS AFTER THE DATE OF SALE.

## Sales and Service

For information about our worldwide locations, approvals, certifications and local representative:

Web site: [www.dezurik.com](http://www.dezurik.com) E-Mail: [info@dezurik.com](mailto:info@dezurik.com)



250 Riverside Ave. N., Sartell, MN 56377 • Phone: 320-259-2000 • Fax: 320-259-2227

*DeZURIK, Inc. reserves the right to incorporate our latest design and material changes without notice or obligation.*

*Design features, materials of construction and dimensional data, as described in this manual, are provided for your information only and should not be relied upon unless confirmed in writing by DeZURIK, Inc. Certified drawings are available upon request.*