

# APCO ASV-401C DUAL BODY SEWAGE COMBINATION AIR VALVES

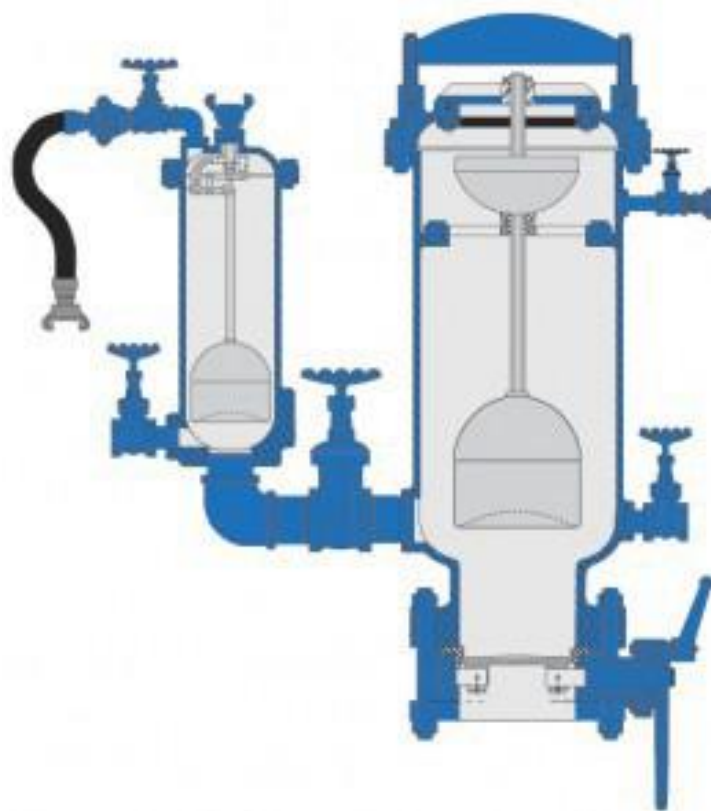

Instruction **D12026**  
March 2022

## Instructions

These instructions are for use by personnel who are responsible for the installation, operation and maintenance of DeZURIK valves, actuators or accessories.

## Safety Messages

All safety messages in the instructions are identified by a general warning sign and the signal word CAUTION, WARNING or DANGER. These messages indicate procedures to avoid injury or death.

Safety label(s) on the product indicate hazards that can cause injury or death. If a safety label becomes difficult to see or read, or if a label has been removed, please contact DeZURIK for replacement label(s).

---

### **⚠WARNING**

**Personnel involved in the installation or maintenance of valves should be constantly alert to potential emission of pipeline material and take appropriate safety precautions. Always wear suitable protection when dealing with hazardous pipeline materials. Handle valves which have been removed from service with suitable protection for any potential pipeline material in the valve.**

---

## Inspection

Your DeZURIK product has been packaged to provide protection during shipment; however, items can be damaged in transport. Carefully inspect the unit for damage upon arrival and file a claim with the carrier if damage is apparent.

## Parts

Replaceable wear parts are listed on the assembly drawing. These parts can be stocked to minimize downtime. Order parts from your local DeZURIK sales representative or directly from DeZURIK. When ordering parts please provide the following information:

**If the valve has a data plate:** please include the 7-digit part number with either 4-digit revision number (example: 9999999R000) or 8-digit serial number (example: S1900001) whichever is applicable. The data plate will be attached to the valve assembly. Also, include the part name, the assembly drawing number, the balloon number and the quantity stated on the assembly drawing.

**If there isn't any data plate visible on the valve:** please include valve model number, part name, and item number from the assembly drawing. You may contact your local DeZURIK Representative to help you identify your valve.

## DeZURIK Service

DeZURIK service personnel are available to maintain and repair all DeZURIK products. DeZURIK also offers customized training programs and consultation services. For more information, contact your local DeZURIK sales representative or visit our website at [DeZURIK.com](http://DeZURIK.com).

### Table of Contents

Description .....	4
Handling and Storage .....	4
Installation .....	4
Fusion Bonded Epoxy Coated Valves.....	4
Maintenance/Backflushing .....	5
<i>Backflushing to Force Main</i> .....	5
Sewage Air/Vacuum Valve .....	5
Maintenance/Backflushing (Continued) .....	6
Sewage Air Release Valve .....	6
Backflushing to Atmospheric or Vacuum Tank.....	7
Sewage Air Release Valve .....	7
Maintenance/Backflushing (Continued) .....	8
Disassembly Procedure.....	9
Maintenance/Backflushing (Continued) .....	10
Assembly Procedure.....	11
Sewage Air/Vacuum Valve .....	11
Operation.....	11
Drawings .....	12
Troubleshooting.....	20

# DeZURIK

## APCO ASV-401C Dual Body Sewage Combination Air Valves

---

### Description

The ASV-401C are Dual Body Sewage Combination Valves with a Sewage Air/Vacuum Valve piped (with a shut-off valve) to a Sewage Air Release Valve. Combination Air Valves vent large volumes of air when the sewage line is filled and allow air to re-enter when draining to prevent vacuum or column separation from occurring. The valve also vents pockets of air through a small orifice.

### Handling and Storage

Lifting the valve improperly may damage it. Do not fasten lifting devices to piping or attached components. Lift the valve with a sling around the flanged end of the body.

If installation will be delayed, place valve indoors in secure, weather tight storage. If temporary outside storage is unavoidable, make sure a vermin proof rain cover (water shedding tarp, etc.) is secured around/over the valve to keep off rain and mud. Skid and set the valve on a flat, solid, and well drained surface for protection from ground moisture, runoff and pooled rain water.

### Installation

Combination Sewage Air Valves are installed on all high points of a system where it has been determined Sewage Air/Vacuum and Sewage Air Release valves are needed to vent and protect a pipeline. These valves should always be installed in a vertical position. An isolation valve between this unit and the transmission (pipeline) system is recommended for inspection and backflushing.

- Before installation, remove foreign material such as weld spatter, oil, grease, and dirt from the pipeline.
- Prepare pipe ends and install valves in accordance with the pipe manufacturer's instructions for the joint used.

---

#### **NOTICE**

**Do not deflect the pipe-valve joint. Minimize bending stresses in the valve end connection with pipe loading.**

---

- Tighten the flange bolts or studs in a crisscross pattern and minimum of four stages.
- The sewage air valve and valve vault should have adequate drainage and be sufficiently protected from possible freezing conditions.
- It is recommended that the sewage air valve discharge ports be ordered threaded and piped to a drain, particularly when installed within a pumping station, to prevent the danger of flooding due to malfunction or clogging.

### Fusion Bonded Epoxy Coated Valves

---

#### **NOTICE**

**Valves with optional fusion bonded epoxy coated exterior require flat washers to be installed under the flange nuts when installing the valve to the pipeline flange. This is to prevent the coating from cracking or chipping.**

---

### Maintenance/Backflushing

The valve should be backflushed to prevent grease and scum buildup inside the valve which can prevent the valve from operating properly. Valves can be ordered with the optional backflushing attachments.

The valve should be backflushed 6 months after the initial operating date. If the initial backflushing process only takes a few minutes to clean the valve, the next backflushing can be scheduled in 12 months. If the initial backflushing process takes 15 minutes or longer to clean the valve, the next backflushing should be scheduled in 3 months.

With the exception of back flushing, Sewage Combination Air Valves are automatic in operation and require very little or no maintenance. It is recommended that they be checked visually semi-annually for leakage. A malfunction of the valve will be evident by leakage of the media out of the seating area of the exhaust port. Should a malfunction occur, the steps starting with the **Disassembly Procedure** should be taken to repair the valve.

### Backflushing to Force Main

If a clean water service is available, it must be at least 15 psi higher than the main pressure, to prevent sewage from back flowing into the potable water line. Backflush Kit hose pressure is not to exceed 200psi.

Valves **(with optional Backflush Attachment)** may be flushed back into the force main by:

#### Sewage Air/Vacuum Valve

See Figures 2, 3, & 6 for part identification

1. Leave the isolation valve between the ASV Sewage Air/Vacuum Valve and the pipeline open.
2. Connect the backflush hose (H15) to ball valve (H11) using the quick disconnect (H12).
3. Backflush for 2 – 3 minutes (or as long as it takes to flush out all the sediment).
4. Close ball valve (H11).
5. After backflushing, close the isolation valve between the ASV Sewage Air/Vacuum Valve and the pipeline.
6. Remove backflush hose (H15) and vent pressure in the valve through ball valve (H11).

---

**⚠WARNING**

**Servicing the Sewage Air/Vacuum Valve while the pipeline is under pressure can cause personal injury or equipment damage. Relieve pipeline pressure or shut off isolation valve before servicing the Sewage Air/Vacuum Valve.**

---

7. Remove cover bolts (A4) and remove the cover (A2).
8. Visually inspect the valve interior. If grease deposits interfere with the valve operation, scrape out grease deposits.

# DeZURIK

## APCO ASV-401C Dual Body Sewage Combination Air Valves

---

### Maintenance/Backflushing (Continued)

9. If the valve was leaking through the outlet port during backflushing, replace the seat (A6) before reassembling the cover (A2).
10. Reassemble cover (A2) and cover bolts (A4). Tighten cover bolts (A4) in a crisscross pattern.  
**Note:** If cover gasket (A3) is damaged, replace cover gasket (A3).
11. Slowly open isolation valve between the ASV Sewage Air/Vacuum Valve and the pipeline to place valve back in service.

### Sewage Air Release Valve

See Figures 1, 4, 5, 7, & 8 for part identification

12. Leave the isolation valve (P8) open.
13. Connect the backflush hose (H15) to ball valve (H11) using the quick disconnect (H12).
14. Backflush for 2 – 3 minutes (or as long as it takes to flush out all the sediment).
15. Close ball valve (H11).
16. Transfer the backflush hose to quick disconnect (H12) in the top of the cover (R2) and flush for 1 minute.
17. After backflushing, close isolation valve (P8).
18. Remove backflush hose (H15) and vent pressure in the valve through ball valve (H11).

---

**⚠WARNING**

**Servicing the Sewage Air Release Valve while the pipeline is under pressure can cause personal injury or equipment damage. Relieve pipeline pressure or shut off isolation valve before servicing the Sewage Air Release Valve.**

---

19. Remove cover bolts (R4) and remove the cover (R2).
20. Visually inspect the valve interior. If grease deposits interfere with the valve operation, scrape out grease deposits.
21. If the valve was leaking through the outlet port during backflushing, replace the seat (R6) and needle (R7) before reassembling the cover (R2).
22. Reassemble cover (R2) and cover bolts (R4). Tighten cover bolts (R4) in a crisscross pattern.  
**Note:** If cover gasket (R3) is damaged, replace cover gasket.
23. Slowly open isolation valve (P8) to place valve back in service.

# DeZURIK

## APCO ASV-401C Dual Body Sewage Combination Air Valves

---

### **Backflushing to Atmospheric or Vacuum Tank**

If a clean water service is not available, with 15 psi higher than the main pressure, backflush through ball valve (H14) into an atmospheric or vacuum collection tank. Backflush Kit hose pressure is not to exceed 200psi.

Valves **(with optional Backflush Attachment)** may be flushed back into tank by:

#### **Sewage Air/Vacuum Valve**

See Figures 2, 3, & 6 for part identification

1. Close isolation valve between ASV Sewage Air/Vacuum Valve and pipeline.
2. Connect ball valve (H14) to an atmospheric or vacuum collection tank.  
**Note:** If a vacuum collection tank is used, a pipe plug with a ¼" hole in it may be inserted into the outlet port of the Sewage Air/Vacuum Valve to limit the amount of air drawn back into the vacuum tank.
3. Open ball valve (H14).
4. Connect the backflush hose (H15) to ball valve (H11).
5. Backflush for 2 – 3 minutes (or as long as it takes to flush out all the sediment).
6. Close ball valve (H11).
7. After backflushing, keep isolation valve between ASV Sewage Air/Vacuum Valve and pipeline closed.
8. Remove backflush hose (H15) and vent pressure in the valve through ball valve (H11).

---

#### **⚠WARNING**

**Servicing the Sewage Air/Vacuum Valve while the pipeline is under pressure can cause personal injury or equipment damage. Relieve pipeline pressure or shut off isolation valve before servicing the Sewage Air/Vacuum Valve.**

---

9. Remove cover bolts (A4) and remove the cover (A2).
10. Visually inspect the valve interior. If grease deposits interfere with the valve operation, scrape out grease deposits.
11. If the valve was leaking through the outlet port during backflushing, replace the seat (A6) before reassembling the cover (A2).
12. Reassemble cover (A2) and cover bolts (A4). Tighten cover bolts (A4) in a crisscross pattern.  
**Note:** If cover gasket (A3) is damaged, replace cover gasket (A3).
13. Close ball valve (H14).
14. Slowly open isolation valve between ASV Sewage Air/Vacuum Valve and pipeline to place valve back in service.

#### **Sewage Air Release Valve**

See Figures 1, 4, 5, 7, & 8 for part identification

15. Close isolation valve (P8).
16. Connect ball valve (H14) to an atmospheric or vacuum collection tank.  
**Note:** If a vacuum collection tank is used, a pipe plug with a ¼" hole in it may be inserted into the outlet port of the Sewage Air/Vacuum Valve to limit the amount of air drawn back into the vacuum tank.
17. Open ball valve (H14).
18. Connect the backflush hose (H15) to ball valve (H11).

### Maintenance/Backflushing (Continued)

19. Backflush for 2 – 3 minutes (or as long as it takes to flush out all the sediment).
20. Close ball valve (H11).
21. Transfer the backflush hose to quick disconnect (H12) in the top of the cover (R2) and flush for 1 minute.
22. After backflushing, close isolation valve (P8).
23. Remove backflush hose (H15) and vent pressure in the valve through ball valve (H11).



#### **WARNING!**

**Servicing the Sewage Air Release Valve while the pipeline is under pressure can cause personal injury or equipment damage. Relieve pipeline pressure or shut off isolation valve before servicing the Sewage Air Release Valve.**

---

24. Remove cover bolts (R4) and remove the cover (R2).
25. Visually inspect the valve interior. If grease deposits interfere with the valve operation, scrape out grease deposits.
26. If the valve was leaking through the outlet port during backflushing, replace the seat (R6) and needle (R7) before reassembling the cover (R2).
27. Reassemble cover (R2) and cover bolts (R4). Tighten cover bolts (R4) in a crisscross pattern.  
**Note:** If cover gasket (R3) is damaged, replace cover gasket (R3).
28. Close ball valve (H14).
29. Slowly open isolation valve (P8) to place valve back in service.



### ***Disassembly Procedure***

#### ***Sewage Air/Vacuum Valve***

See Figures 2-3 for part identification.

---

**▲WARNING**

**Servicing the Sewage Air/Vacuum Valve while the pipeline is under pressure can cause personal injury or equipment damage. Relieve pipeline pressure or shut off isolation valve before servicing the Sewage Air/Vacuum Valve.**

---

1. Relieve pipeline pressure or shut off isolation valve at inlet to Sewage Air/Vacuum Valve before servicing the Air Valve.

---

**▲WARNING**

**Do not completely remove pipe plugs or cover bolts while the valve is under pressure.**

---

2. Slowly loosen pipe plug (A44) in body (A1) to relieve internal pressure. **Do not completely remove pipe plug while the valve is under pressure.**
3. Check to see if foreign matter or dirt is preventing upper float (A14) from seating properly against seat (A6). Clean as necessary.
4. Perform a seat test. Replace pipe plug and slowly fill valve chamber by cracking open isolation valve on inlet pipe. If seepage persists, repeat Steps 1 and 2 and proceed as follows:
5. Remove cover bolts (A4) and cover (A2).

**Note:** Internals are attached to the cover.

6. **For 4-14" (100-355mm) ASV Only:**
  - a. Remove guide plate screws (A34) and guide plate (A5).

# DeZURIK

## APCO ASV-401C Dual Body Sewage Combination Air Valves

---

### Maintenance/Backflushing (Continued)

7. If cover gasket (A3) is torn or damaged, clean flange surfaces of cover (A2) and body (A1). Replace cover gasket (A3) if necessary.
8. Remove baffle/seat screws (A34/A16).
9. Remove seat (A6) from cover (A2).
10. Inspect sealing surface of upper float (A14) and seat (A6) for nicks, wear or sediment coating from chemicals in the media. Clean or replace if necessary.
11. Inspect lower float (A15) to ensure that it is not damaged or that it does not have liquid in it.
12. Inspect all connections of linkage for excessive wear. Replace if necessary.
13. Clean all surfaces before re-assembly.

### ASR-400/450 Sewage Air Release Valve

See Figures 4-5 for part identification.

---

#### **▲WARNING**

**Servicing the Sewage Air Release Valve while the pipeline is under pressure can cause personal injury or equipment damage. Relieve pipeline pressure or shut off isolation valve before servicing the Sewage Combination Air Valve.**

---

14. Relieve pipeline pressure or shut off isolation valve at inlet to Sewage Air Release Valve.

---

#### **▲WARNING**

**Do not completely remove pipe plugs or cover bolts while the valve is under pressure.**

---

15. Loosen pipe plug (R17/R18) in cover (R2) to relieve internal pressure. **Do not completely remove pipe plug while the valve is under pressure.**
16. Remove cover bolts (R4) and cover (R2) from the valve body (R1). **Note:** All internals are attached to the cover.
17. If cover gasket (R3) is torn or damaged, clean flange surfaces of cover (R2) and body (R1). Replace cover gasket (R3) if necessary.
18. Inspect sealing surface of needle (R7) and seat (R6) for nicks, wear or sediment coating from chemicals in the media. Clean or replace if necessary.
19. Inspect float (R14) to ensure that it is not damaged or that it does not have liquid in it. Replace float (R14) if damaged.
20. Inspect all components attached to the cover (R2) for excessive wear.
21. Clean all surfaces before re-assembly.

# DeZURIK

## APCO ASV-401C Dual Body Sewage Combination Air Valves

---

### **Assembly Procedure**

#### **ASR-400/450 Sewage Air Release Valve**

See Figures 4-5 for part identification.

1. Re-assemble in the opposite order as disassembly procedure.
2. Assemble cover (R2) and attached components to body (R1), installing new cover gasket (R3) if necessary. Tighten cover bolts (R4) opposite each other in rotation.
3. Install and secure pipe plug (R17/R18) in cover (R2).
4. Open isolation valve on inlet to Sewage Air Release Valve. Valve is now back in service.

#### **Sewage Air/Vacuum Valve**

See Figures 2-3 for part identification.

5. Re-assemble in the opposite order as disassembly procedure.
6. Assemble seat (A6) and baffle (A24) (if applicable) to cover (A2) using baffle/seat screws (A34/A16).  
**For sizes 1.2"-3" Only:** Be sure that upper float (A14) is positioned such that it sits square on seat (A6). Improper positioning of baffle (A24) to cover (A2) before tightening baffle screws (A34) can result in leakage between the upper float (A14) and seat (A6).
7. **For 4-14" (100-355mm) ASV Only:**
  - a. Assemble guide plate (A5) to body (A1) using guide plate screws (A34). Be sure guide plate (A5) is placed in same orientation as removed to ensure proper alignment between the upper float (A14) and seat (A6) for sealing.
8. Assemble cover (A2) and attached components to body (A1), installing new cover gasket (A3) if necessary. Tighten cover bolts (A4) opposite each other in rotation.
9. Install and secure pipe plug (A44) in body (A1).
10. Open isolation valve on inlet to Sewage Air/Vacuum Valve.

### **Testing**

See Figures 2-5 for part identification.

11. Perform a seat test. Restore pipeline pressure and slowly fill the Sewage Air/Vacuum valve chamber by cracking open the isolation valve below the Sewage Air/Vacuum Valve. If seepage occurs once the upper float (A14) or needle (R7) is in contact with the seat (A6/R6), reference to the "Disassembly Procedure" and replace seat, needle, and/or float.

### **Operation**

Combination Sewage Air Valves prevent accumulation of air at high points within a system by exhausting large volumes of air as the system is filled and releasing accumulated pockets of air while the system is operational and under pressure. They also prevent potentially destructive vacuums from forming by admitting large quantities of air into the system. This can occur during power outage, water column separation or sudden rupture of the pipeline. Additionally, these valves allow the system to be easily drained because air will re-enter as needed.

Drawings

CONNECTING PARTS		
ITEM	DESCRIPTION	QTY
P5	NIPPLE	1
P6	NIPPLE	1
P7	ELBOW	1
P8	BALL VALVE OR GATE VALVE (See Note 1)	1

**NOTE:**  
1) A BALL VALVE IS USED FOR CLEAN WATER AND  
A GATE VALVE IS USED FOR SEWAGE VALVES.

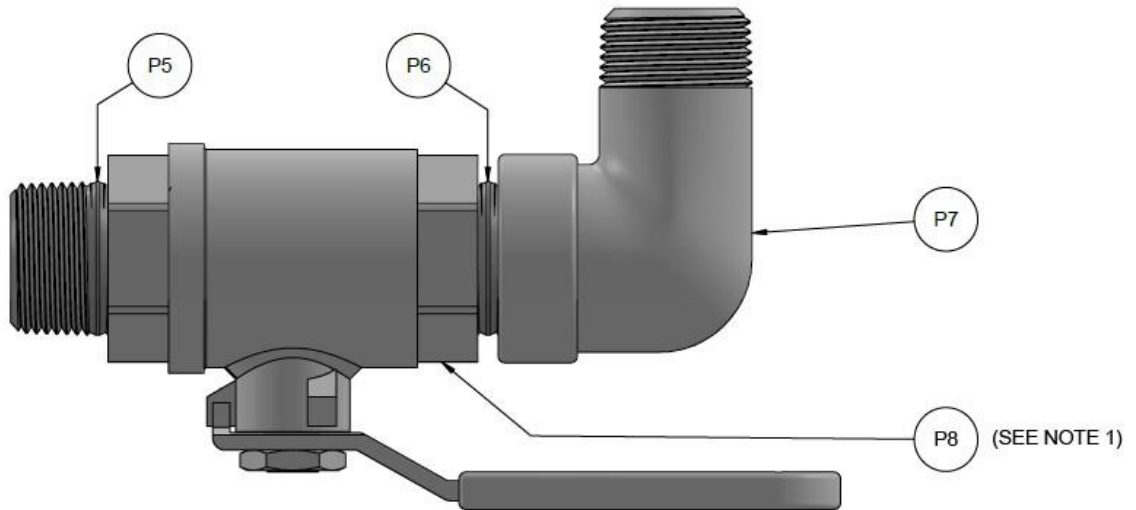

FOR 4"-24" AVV DUAL BODY AND 1.2"-14" ASV DUAL BODY ONLY

Figure 1: Connecting Parts for Dual Body ASV

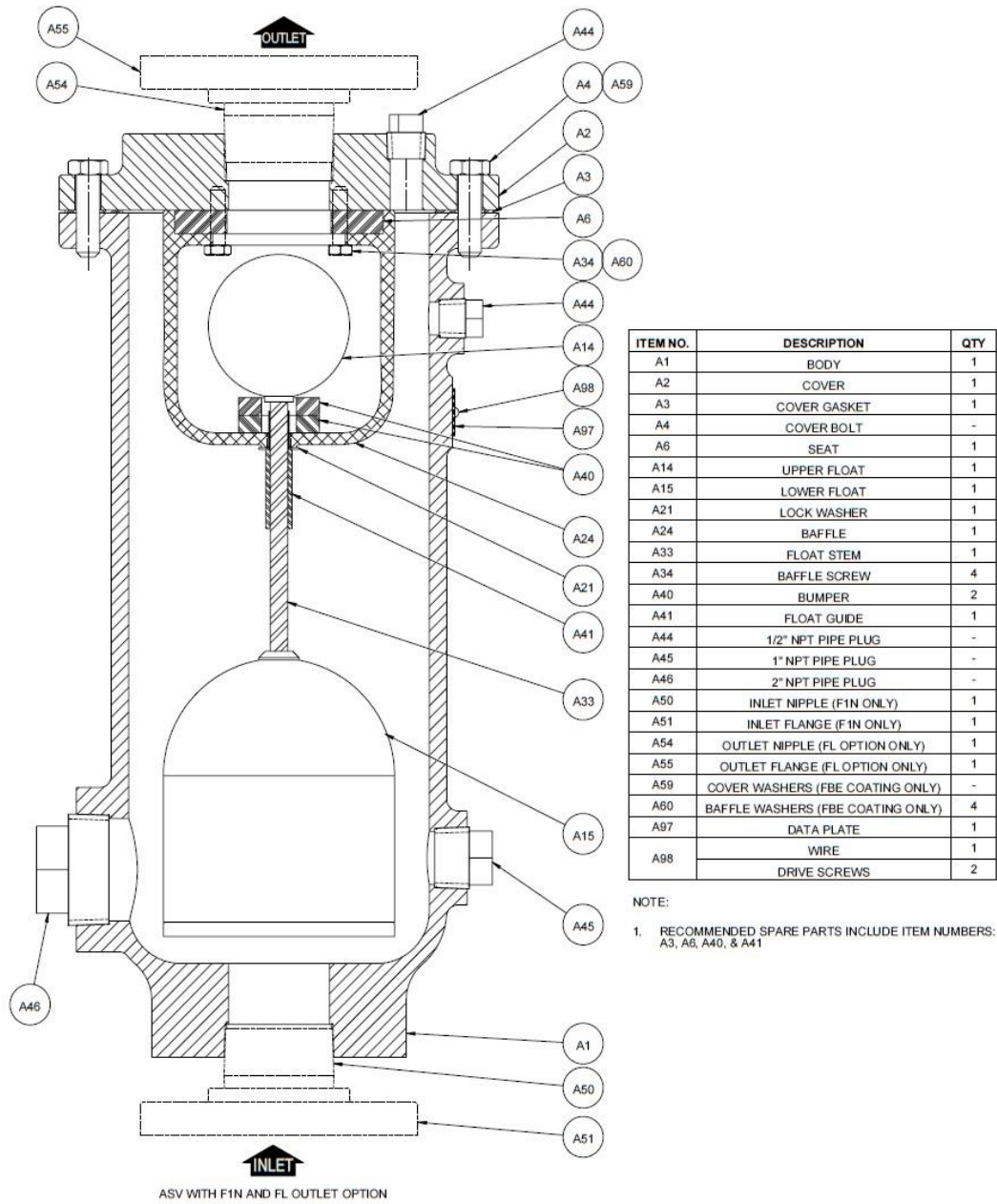
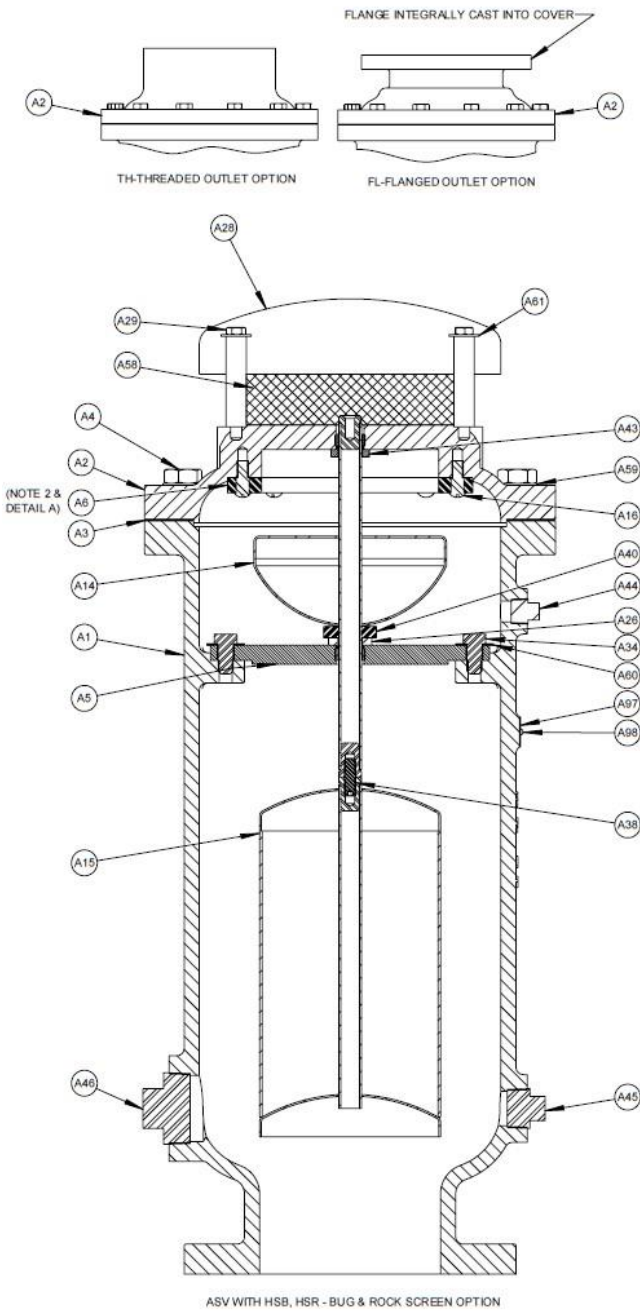

Figure 2: ASV-401 1.2-3" (25.50-80mm) Sewage Air/Vacuum Valve



ITEM NO.	DESCRIPTION	QTY.
A1	BODY	1
A2	COVER	1
A3	COVER GASKET	1
A4	COVER BOLTS	-
A5	GUIDE PLATE	1
A6	SEAT	1
A14	UPPER FLOAT	1
A15	LOWER FLOAT	1
A16	SEAT RETAINING SCREW	-
A26	LOWER GUIDE BUSHING	1
A28	HOOD	1
A29	HOOD SCREWS	4
A34	GUIDE PLATE SCREWS	2
A38	FLOAT SET SCREW	1
A40	BUMPER	1
A43	UPPER GUIDE BUSHING	1
A44	1/2" PIPE PLUG	-
A45	1" PIPE PLUG	-
A46	2" PIPE PLUG	-
A50	NIPPLE (4" F1N ONLY)	1
A51	FLANGE (4" F1N ONLY)	1
A58	BUG SCREEN (4"-14" HSR/MSB OPTION ONLY)	1
A59	COVER WASHERS (EXTERIOR FBE COATING ONLY)	-
A60	GUIDE PLATE WASHER (INTERIOR FBE COATING ONLY)	2
A61	HOOD WASHER (EXTERIOR FBE COATING ONLY)	4
A97	DATA PLATE	1
A98	DRIVE SCREWS	2

- NOTE:
1. RECOMMENDED SPARE PARTS INCLUDE ITEM NUMBERS: A3, A6, A26, A40, & A43.
  2. THE SEAT PROVIDED CAN BE EITHER SOLID RUBBER OR A METAL OVERMOLDED SEAT DEPENDING ON SIZE AND WORKING PRESSURE.

Figure 3: ASV-401 4-14" (100-355mm) Sewage Air/Vacuum Valve

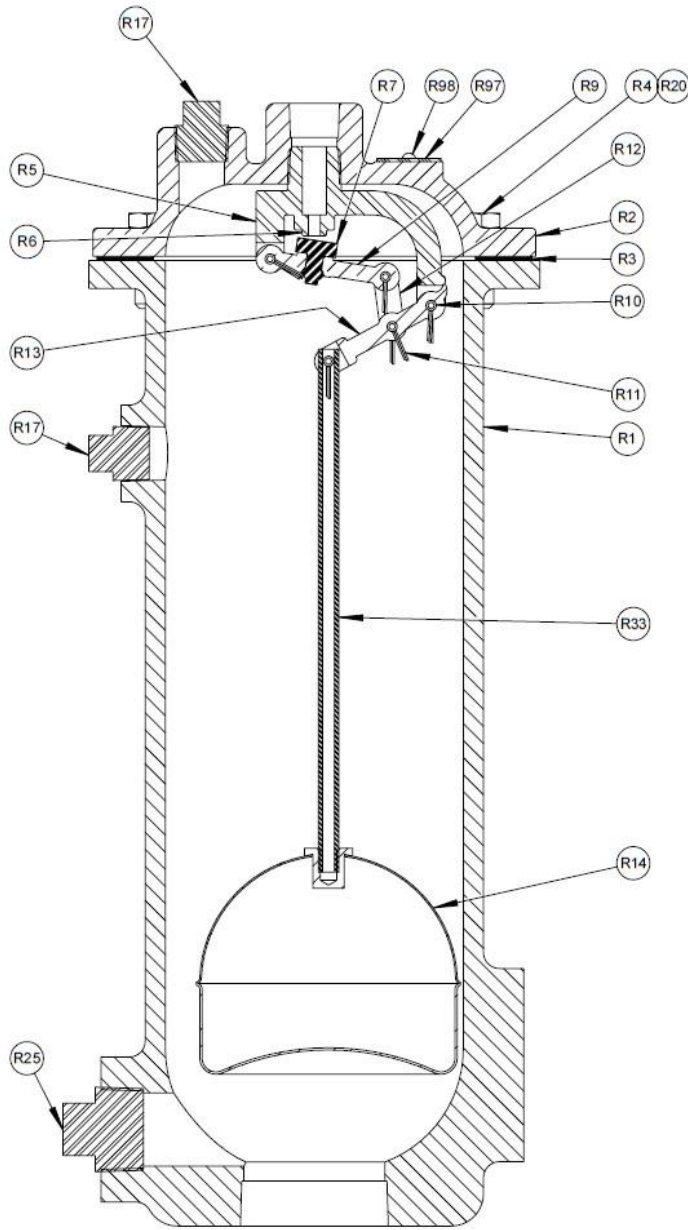

ASR 400 WITH T1 INLET SHOWN

ITEM NO.	DESCRIPTION	QTY
R1	BODY	1
R2	COVER	1
R3	COVER GASKET	1
R4	COVER BOLT	6
R5	LEVERAGE FRAME	1
R6	SEAT (5/16" ORIFICE ONLY)	1
R7	NEEDLE	1
R9	NEEDLE LEVER	1
R10	LEVER PIN	5
R11	RETAINING RING / COTTER PIN	10
R12	CONNECTING LINK	2
R13	FLOAT LEVER	1
R14	FLOAT	1
R17	1/2" NPT PIPE PLUG	-
R20	COVER WASHER (FBE ONLY)	6
R25	1" NPT PIPE PLUG	-
R33	FLOAT STEM	1
R50	NIPPLE (F1N ONLY)	1
R51	FLANGE (F1N ONLY)	1
R97	DATA PLATE	1
R98	DRIVE SCREWS	2

NOTE:  
 1. RECOMMENDED SPARE PARTS INCLUDE ITEM NUMBERS: R3, R6, R7, R10, & R11

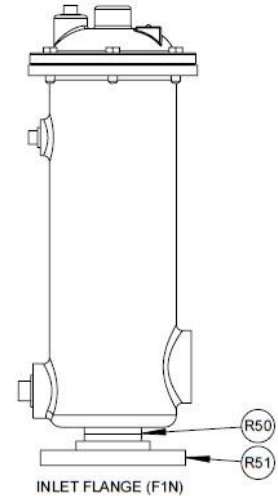
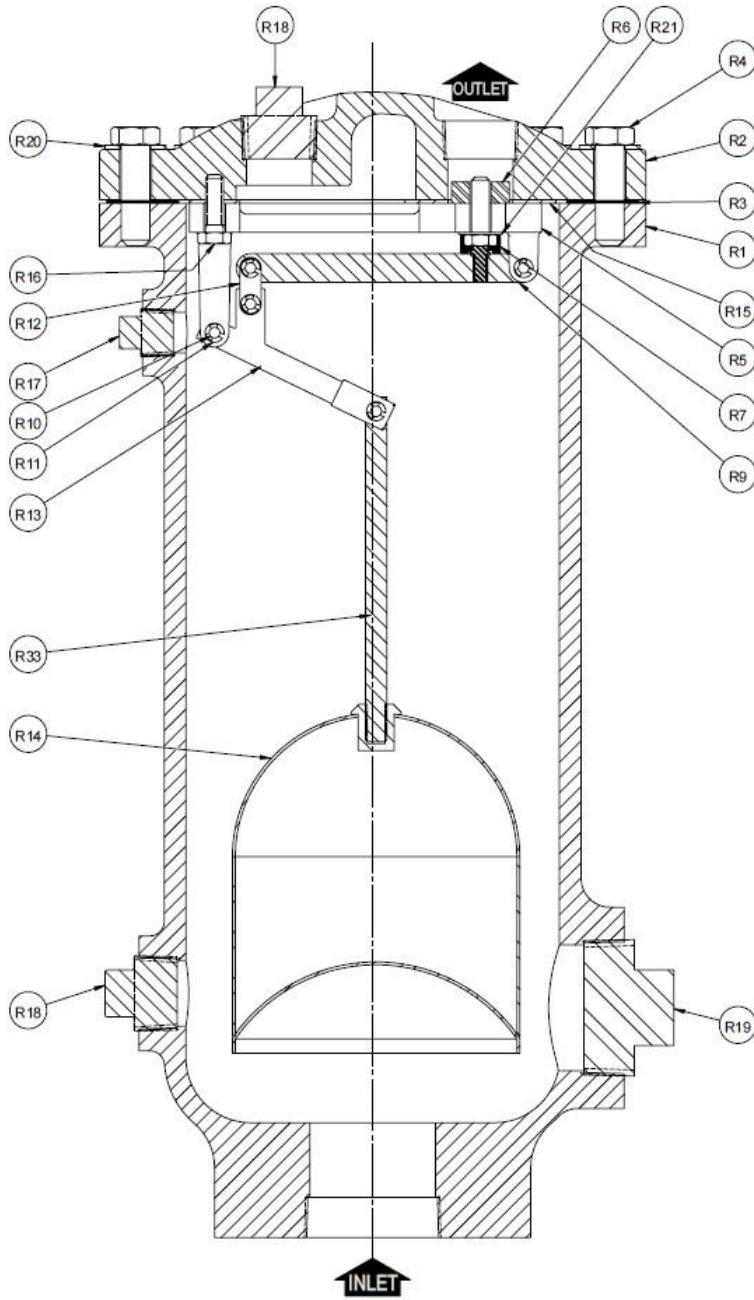

Figure 4: ASR-400 Sewage Air Release Valve



DET	DESCRIPTION	QTY
R1	BODY	1
R2	COVER	1
R3	COVER GASKET	1
R4	COVER BOLT	8
R5	LEVERAGE FRAME	1
R6	SEAT	1
R7	NEEDLE	1
R9	NEEDLE LEVER	1
R10	LEVER PIN	5
R11	RETAINING RING/COTTER PIN	10
R12	CONNECTING LINK	2
R13	FLOAT LEVER	1
R14	FLOAT	1
R15	LEVERAGE FRAME GASKET	1
R16	LEVERAGE FRAME SCREW	4
R17	1/2" NPT PIPE PLUG	-
R18	1" NPT PIPE PLUG	-
R19	2" NPT PIPE PLUG	1
R20	COVER WASHER (FBE ONLY)	8
R21	LEVERAGE FRAME WASHER	2
R33	FLOAT STEM	1
R50	NIPPLE (F1N ONLY)	1
R51	FLANGE (F1N ONLY)	1
R97	DATA PLATE	1
R98	DRIVE SCREWS	2

Note:  
 1. RECOMMENDED SPARE PARTS INCLUDE ITEM NUMBERS: R3, R6, R7, R10, R11, & R15

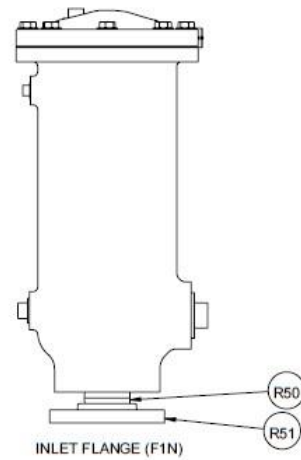
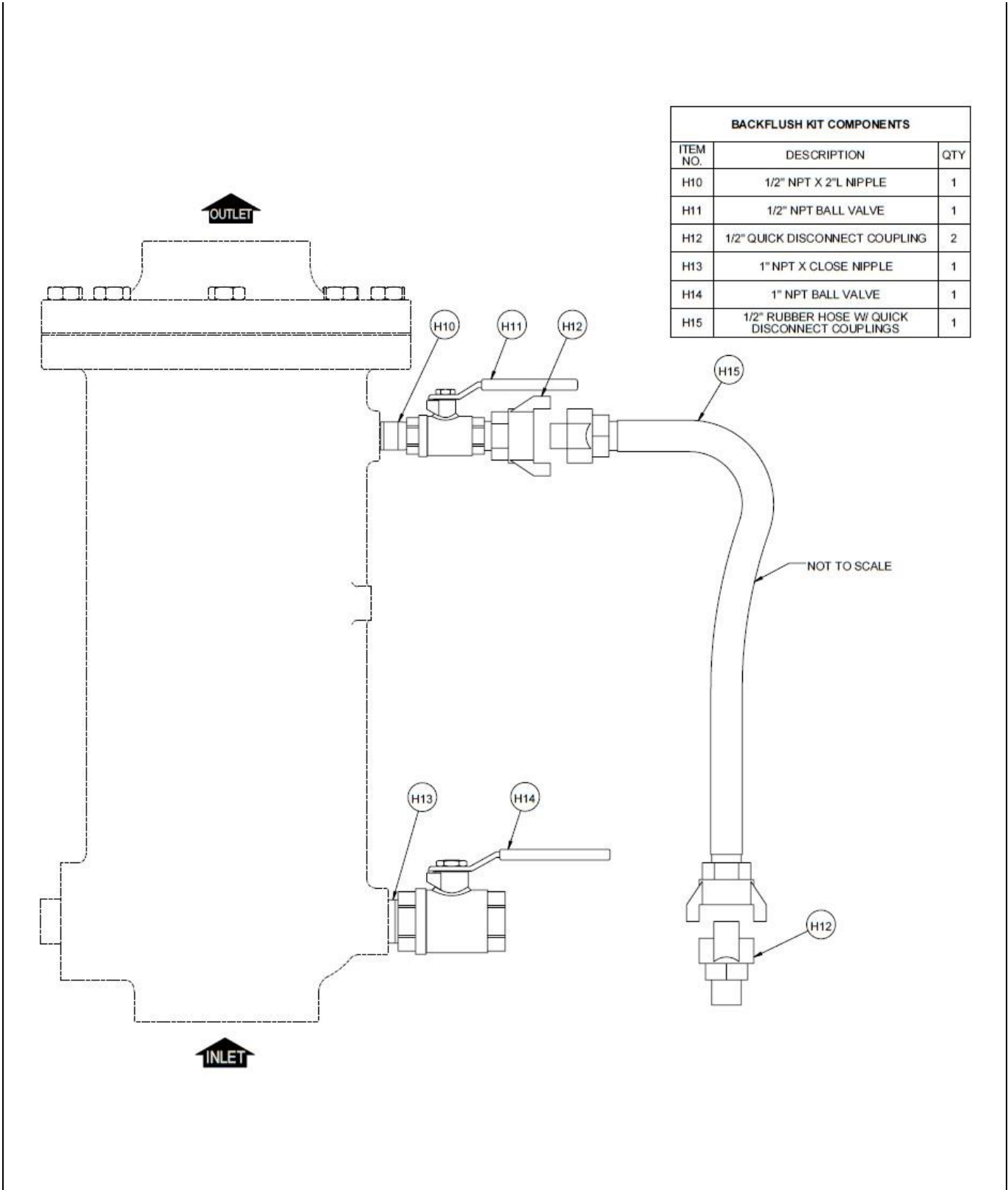

Figure 5: ASR-450 Sewage Air Release Valve





**Figure 6: ASV-401 Sewage Air/Vacuum Valve BFK Backflush Kit**

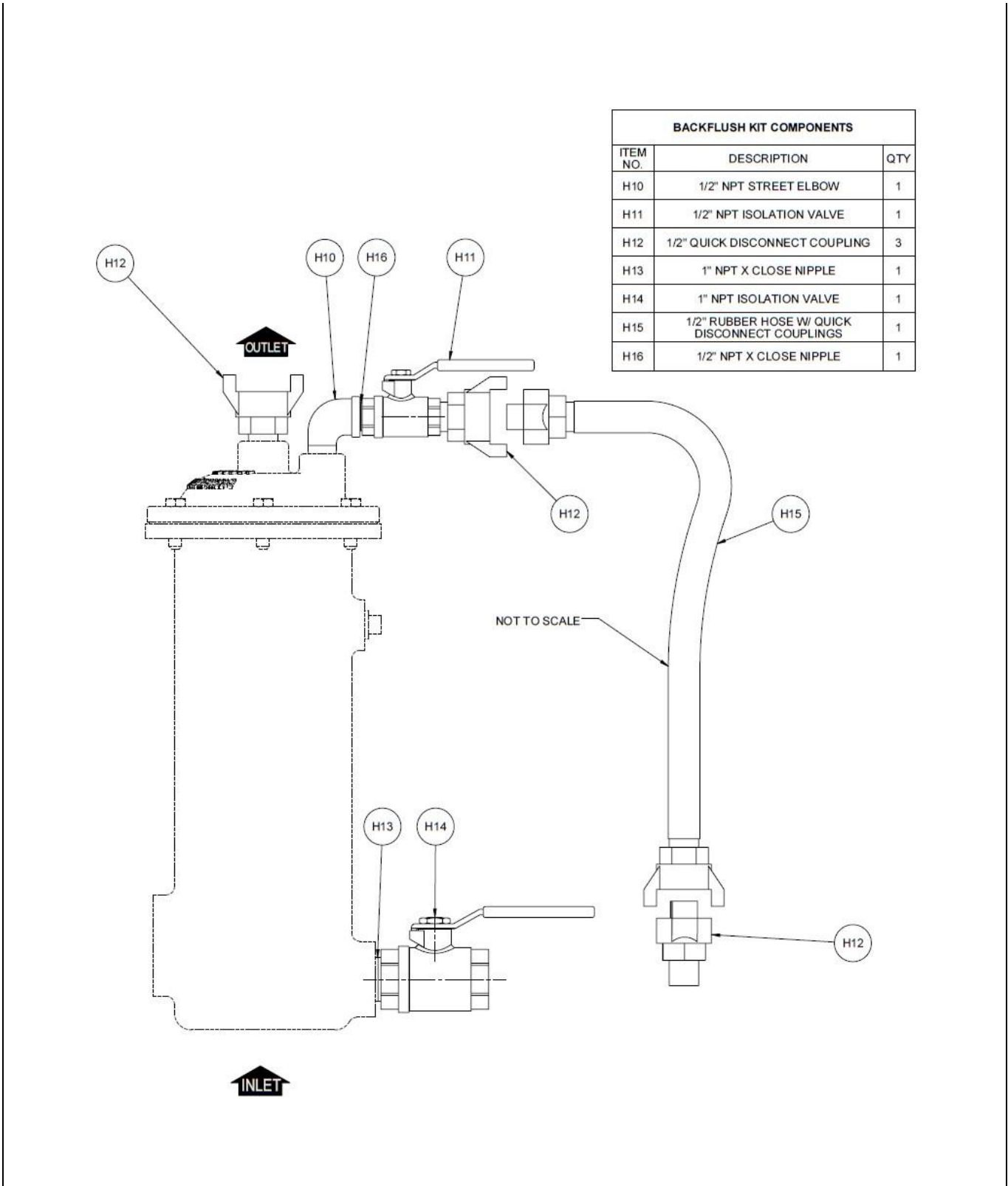
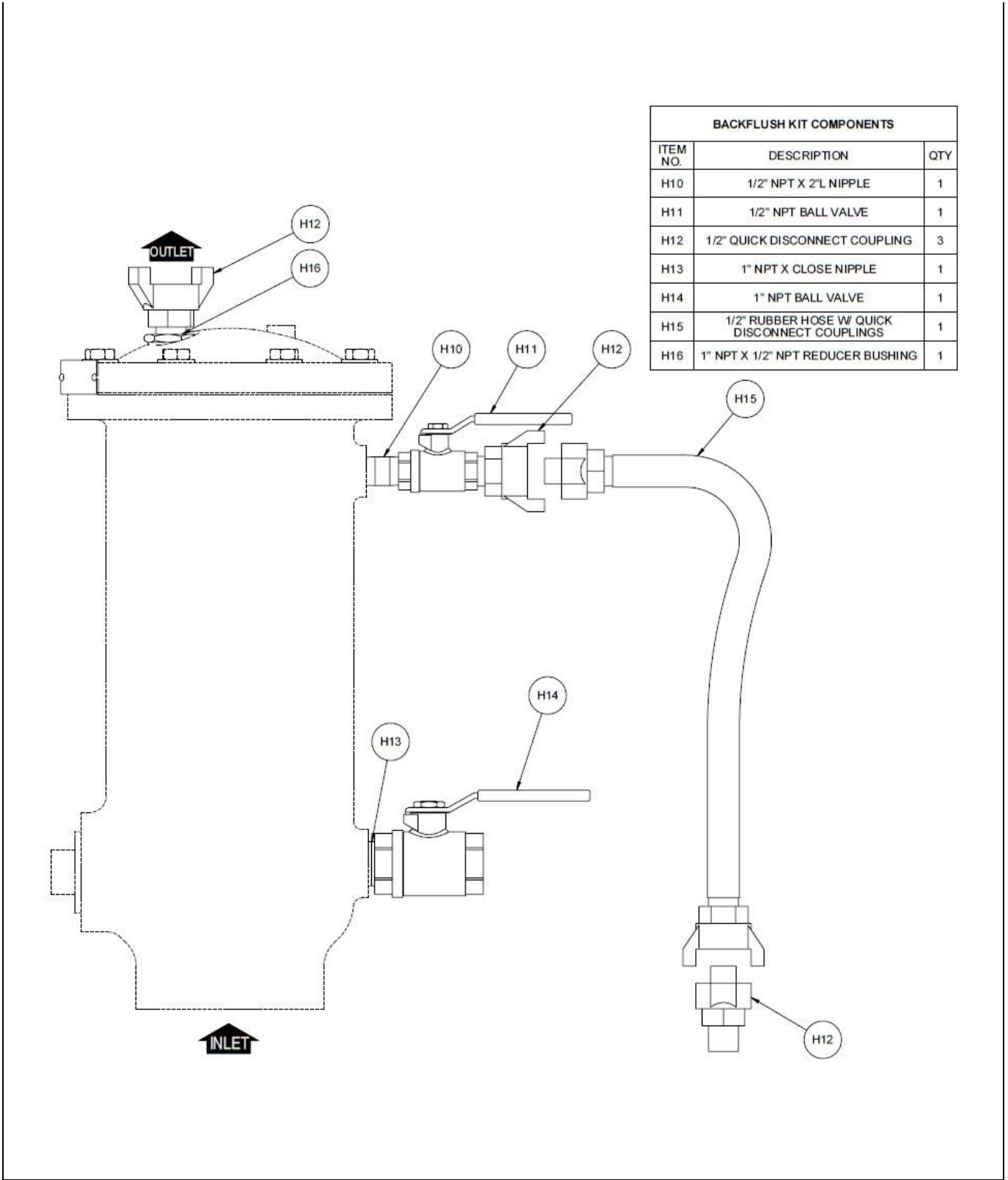

Figure 7: ASR-400 Sewage Air Release Valve BFK Backflush Kit



**Figure 8: ASR-450 Sewage Air Release Valve BFK Backflush Kit**

### Troubleshooting

Condition	Possible Cause	Corrective Action
Valve leaks at flange joint.	Loose flange bolting.	Tighten flange bolting.
	Blown flange gasket.	Replace flange gasket.
	Misalignment or damage to field piping and supports.	Adjust misalignment or repair piping or supports.
	Damaged flange face/s or improper flange connections.	Repair flange, replace valve body or adjust flange connections.
Valve leaks out of outlet port.	Line pressure is under valve working pressure.	Replace seat and/or needle with softer seat and/or needle.
	Worn needle and/or orifice.	Replace needle and/or orifice.
	Float does not move freely.	Readjust position of leverage frame to cover.
	Float has liquid in it.	Replace float.
	Dirty seat and/or upper float.	Clean seat and/or upper float.
	Worn seat and/or upper float.	Replace seat and/or upper float.
	Dirty needle and/or orifice of leverage frame.	Clean needle and/or orifice of leverage frame.
	Float stem/linkage is dirty.	Clean float stem/linkage.

## Limited Warranty

DeZURIK, Inc. ("Seller") manufactured products, auxiliaries and parts thereof that we manufacture for a period of twenty-four (24) months from date of shipment from Seller's factory, are warranted to the original purchaser only against defective workmanship and material, but only if properly stored, installed, operated, and serviced in accordance with Seller's recommendations and instructions.

For items proven to be defective within the warranty period, your exclusive remedy under this limited warranty is repair or replacement of the defective item, at Seller's option, FCA Incoterms 2020 Seller's facility with removal, transportation, and installation at your cost.

Products or parts manufactured by others but furnished by Seller are not covered by this limited warranty. Seller may provide repair or replacement for other's products or parts only to the extent provided in and honored by the original manufacturer's warranty to Seller, in each case subject to the limitations contained in the original manufacturer's warranty.

No claim for transportation, labor, or special or consequential damages or any other loss, cost or damage is being provided in this limited warranty. You shall be solely responsible for determining suitability for use and in no event shall Seller be liable in this respect.

This limited warranty does not warrant that any Seller product or part is resistant to corrosion, erosion, abrasion or other sources of failure, nor does Seller warrant a minimum length of service.

Your failure to give written notice to us of any alleged defect under this warranty within twenty (20) days of its discovery, or attempts by someone other than Seller or its authorized representatives to remedy the alleged defects therein, or failure to return product or parts for repair or replacement as herein provided, or failure to store, install, or operate said products and parts according to the recommendations and instructions furnished by Seller shall be a waiver by you of all rights under this limited warranty.

This limited warranty is voided by any misuse, modification, abuse or alteration of Seller's product or part, accident, fire, flood or other Act of God, or your failure to pay entire contract price when due.

The foregoing limited warranty shall be null and void if, after shipment from our factory, the item is modified in any way or a component of another manufacturer, such as but not limited to; an actuator is attached to the item by anyone other than a Seller factory authorized service personnel.

All orders accepted shall be deemed accepted subject to this limited warranty, which shall be exclusive of any other or previous warranty, and this shall be the only effective guarantee or warranty binding on Seller, despite anything to the contrary contained in the purchase order or represented by any agent or employee of Seller in writing or otherwise, notwithstanding, including but not limited to implied warranties.

THE FOREGOING REPAIR AND REPLACEMENT LIMITED WARRANTY IS IN LIEU OF ALL OTHER WARRANTIES, OBLIGATIONS AND LIABILITIES, INCLUDING, BUT NOT LIMITED TO, ALL WARRANTIES OF FITNESS FOR A PARTICULAR PURPOSE OR OF MERCHANTABILITY OR OTHERWISE, EXPRESSED OR IMPLIED IN FACT OR BY LAW, AND STATE SELLER'S ENTIRE AND EXCLUSIVE LIABILITY AND YOUR EXCLUSIVE REMEDY FOR ANY CLAIM IN CONNECTION WITH THE SALE AND FURNISHING OF SERVICES, GOODS OR PARTS, THEIR DESIGN, SUITABILITY FOR USE, INSTALLATION OR OPERATIONS. NEITHER ANY PERFORMANCE OR OTHER CONDUCT, NOR ANY ORAL OR WRITTEN INFORMATION, STATEMENT, OR ADVICE PREPARED BY SELLER OR ANY OF OUR EMPLOYEES OR AGENTS WILL CREATE A WARRANTY, OR IN ANY WAY INCREASE THE SCOPE OR DURATION OF THE LIMITED WARRANTY.

## Disclaimer

Metric fasteners should not be used with ASME Class 150/300 bolt holes and flange bolt patterns. If you use metric fasteners with ASME Class 150/300 bolt holes and flange bolt patterns, it may lead to product failure, injury, and loss of life. DeZURIK Inc. disclaims all liability associated with the use of metric fasteners with ASME Class 150/300 bolt holes and flange patterns, including but not limited to personal injury, loss of life, loss of product, production time, equipment, property damage, lost profits, consequential damages of any kind and environment damage and/or cleanup. Use of metric fasteners with ASME Class 150/300 bolt holes and flange bolt patterns is a misuse that voids all warranties and contractual assurances. If you use metric fasteners with ASME Class 150/300 bolt holes and flange bolt patterns, you do so at your sole risk and any liability associated with such use shall not be the responsibility of DeZURIK, Inc. In addition to the foregoing, DeZURIK's Manufacturer's Conditions apply.

## Limitation of Liability

IN NO EVENT SHALL SELLER BE LIABLE FOR ANY DIRECT, INDIRECT, SPECIAL, PUNITIVE, EXEMPLARY, OR CONSEQUENTIAL DAMAGES (INCLUDING, BUT NOT LIMITED TO; DAMAGE TO OR LOSS OF OTHER PROPERTY OR EQUIPMENT, BUSINESS INTERRUPTION, COST OF SUBSTITUTE PRODUCTS, LOSS OF TIME, LOSS OF PROFITS OR REVENUE, COST OF CAPITAL, LOSS OF USE, OR DIMINUTION IN VALUE) WHATSOEVER, AND SELLER'S LIABILITY, UNDER NO CIRCUMSTANCES, WILL EXCEED THE CONTRACT PRICE FOR THE GOODS AND/OR SERVICES FOR WHICH LIABILITY IS CLAIMED. ANY ACTION FOR BREACH OF CONTRACT BY YOU, OTHER THAN RIGHTS RESPECTING OUR LIMITED WARRANTY DESCRIBED ABOVE, MUST BE COMMENCED WITHIN 12 MONTHS AFTER THE DATE OF SALE.

## Sales and Service

For information about our worldwide locations, approvals, certifications and local representative:

Web site: [www.dezurik.com](http://www.dezurik.com) E-Mail: [info@dezurik.com](mailto:info@dezurik.com)



250 Riverside Ave. N., Sartell, MN 56377 • Phone: 320-259-2000 • Fax: 320-259-2227

*DeZURIK, Inc. reserves the right to incorporate our latest design and material changes without notice or obligation.*

*Design features, materials of construction and dimensional data, as described in this manual, are provided for your information only and should not be relied upon unless confirmed in writing by DeZURIK, Inc. Certified drawings are available upon request.*