

APCO CVS-250/250A SWING CHECK VALVES

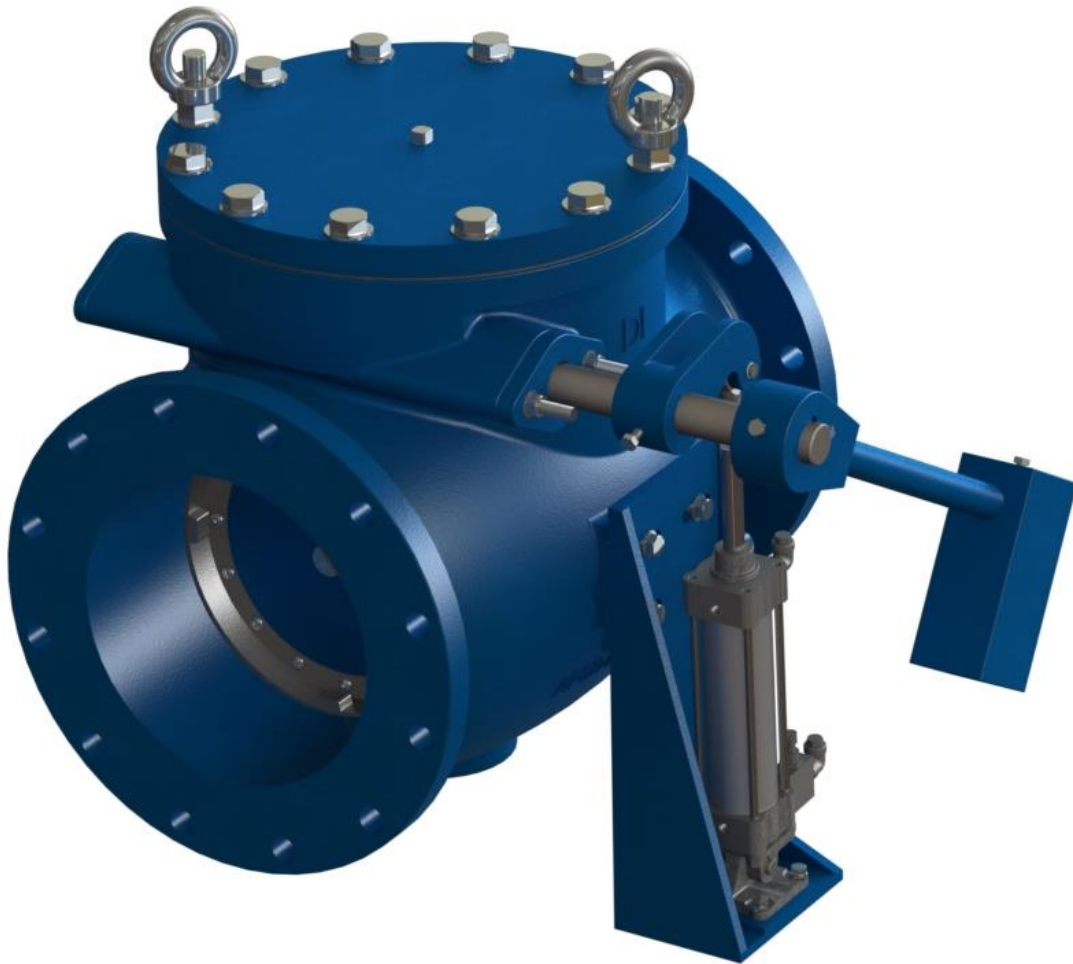

Instruction **D12003**
March 2023

Instructions

These instructions are for use by personnel who are responsible for the installation, operation and maintenance of DeZURIK valves, actuators or accessories.

Safety Messages

All safety messages in the instructions are identified by a general warning sign and the signal word CAUTION, WARNING or DANGER. These messages indicate procedures to avoid injury or death.

Safety label(s) on the product indicate hazards that can cause injury or death. If a safety label becomes difficult to see or read, or if a label has been removed, please contact DeZURIK for replacement label(s).

⚠WARNING

Personnel involved in the installation or maintenance of valves should be constantly alert to potential emission of pipeline material and take appropriate safety precautions. Always wear suitable protection when dealing with hazardous pipeline materials. Handle valves which have been removed from service with suitable protection for any potential pipeline material in the valve.

Inspection

Your DeZURIK product has been packaged to provide protection during shipment; however, items can be damaged in transport. Carefully inspect the unit for damage upon arrival and file a claim with the carrier if damage is apparent.

Parts

Replaceable wear parts are listed on the assembly drawing. These parts can be stocked to minimize downtime. Order parts from your local DeZURIK sales representative or directly from DeZURIK. When ordering parts please provide the following information:

If the valve has a data plate: please include the 7-digit part number with either 4-digit revision number (example: 9999999R000) or 8-digit serial number (example: S1900001) whichever is applicable. The data plate will be attached to the valve assembly. Also, include the part name, the assembly drawing number, the balloon number and the quantity stated on the assembly drawing.

If there isn't any data plate visible on the valve: please include valve model number, part name, and item number from the assembly drawing. You may contact your local DeZURIK Representative to help you identify your valve.

DeZURIK Service

DeZURIK service personnel are available to maintain and repair all DeZURIK products. DeZURIK also offers customized training programs and consultation services. For more information, contact your local DeZURIK sales representative or visit our website at DeZURIK.com.

Table of Contents

Description	3
Handling and Storage	3
Installation.....	3
Fusion Bonded Epoxy Coated Valves.....	4
Maintenance	4
Shaft Packing Adjustment	4
Shaft Packing Replacement	5
Disc Seat Replacement	5
Changing Counterweight or Spring Assembly to Opposite Side of Valve.....	6
Adding Air Cushion Assembly to Valve	7
Operation	8
Closure Speed Control Adjustment (Valves with Lever & Weight)	8
Closure Speed Control Adjustment (Valves with Air Cushion)	8
Start-up Procedure	9
Adjustment (Valves with Air Cushion with Lever & Weight).....	9
Adjustment (Valves with Lever & Weight).....	9
Drawings	10
Troubleshooting	14

Description

A swing check valve consists of a valve body, a cover, and a disc that is connected to a hinge. The disc swings away from the valve-seat to allow flow in the forward direction, and returns to valve-seat when upstream flow is stopped, to prevent backflow. The valve is equipped with either a lever & weight, an air cushion with lever & weight, or a lever & spring to assist with closing the valve.

Handling and Storage

Lifting the valve improperly may damage it. Do not fasten lifting devices to the lever arm actuator or through the seat opening in the body. Lift the valve with slings, chains or cables fastened around the valve body, or fastened to bolts or rods through bolt holes in the flanges.

If installation will be delayed, place valve indoors in secure, weather tight storage. If temporary outside storage is unavoidable, make sure a vermin proof rain cover (water shedding tarp, etc.) is secured around/over the equipment to keep off rain and mud. Skid and set the assembly on a flat, solid, and well drained surface for protection from ground moisture, runoff and pooled rain water.

Installation

- The APCO CVS 250/250A Swing Check Valve may be installed in a horizontal or vertical position (with the flow upward). In either case, the Counterweight Arm (B19) should be set in horizontal position. Unless otherwise specified, the valves are shipped for horizontal installation.
 - To change the counterweight arm position, loosen the Lever Arm Bolt Set Screw (B55), slide the counterweight arm assembly off the Pivot Shaft (A13), rotate the counterweight arm assembly and slide it back onto the Pivot Shaft (A13) using the appropriate keyway shown in Figure 1. See Figure 2 for component identification.

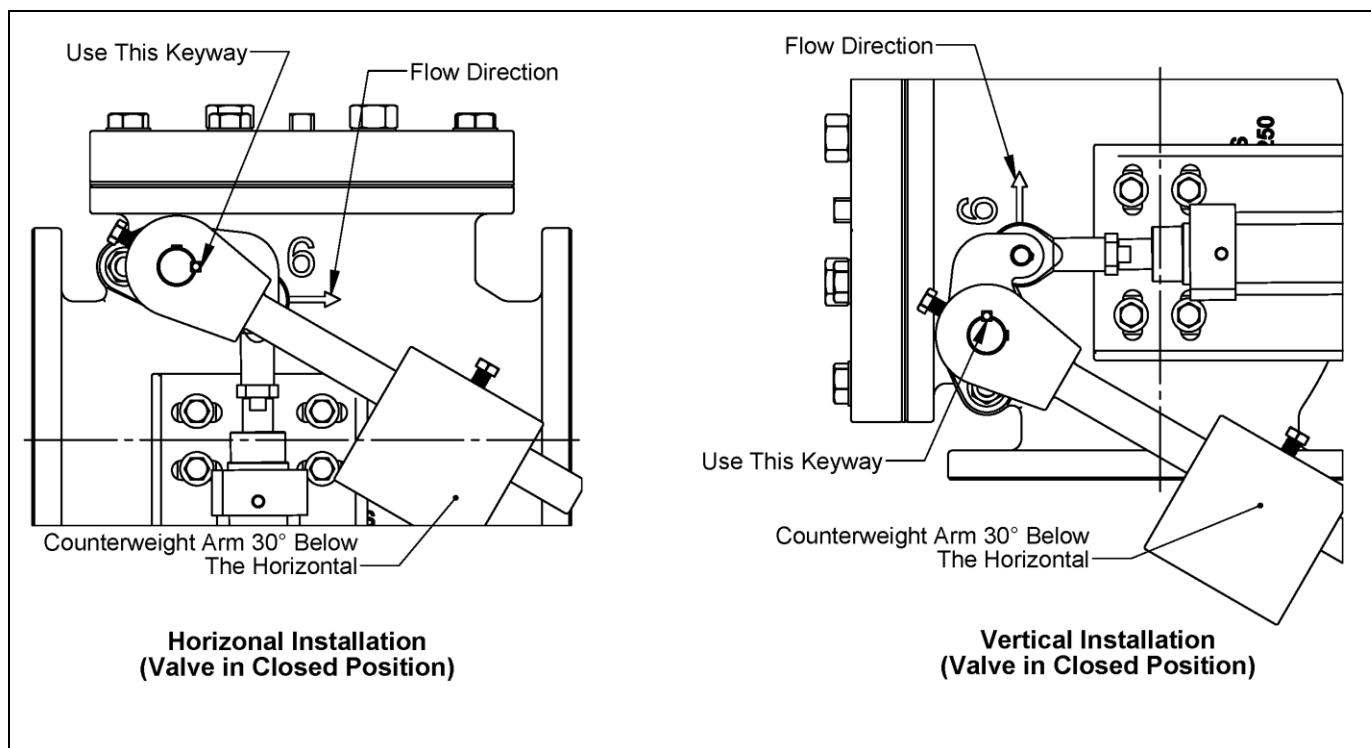

Figure 1 – Counterweight Arm Position

Installation *(Continued)*

- Before installation, remove foreign material such as weld spatter, oil, grease, and dirt from the pipeline.
- Prepare pipe ends and install valves in accordance with the pipe manufacturer's instructions for the joint used.

NOTICE

The recommendation by Manufacturers Standardization Society of the Valve and Fittings Industry (MSS SP- 92) is to install a check valve at a minimum of 10 pipe diameters of straight pipe on the downstream side from tees, fittings, increasers, or pumps and 5 pipe diameters from elbows to ensure laminar flow with minimum turbulence to minimize disc movement and premature wear. However, many facilities with smaller footprints have achieved acceptable performance in systems with the check valve installed 5 pipe diameter lengths of straight pipe from the downstream side of tees, fittings, increasers, or pumps and 3 pipe diameters lengths from elbows.

NOTICE

Do not deflect the pipe-valve joint. Minimize bending stresses in the valve end connection with pipe loading. If excessive seat leakage occurs during start-up, recheck the installation and eliminate any distortion to the valve body.

-
- Ensure the valve and pipeline flanges are concentric to ensure proper flange sealing and seat leakage control.
 - Tighten the flange bolts or studs in a crisscross pattern and minimum of four stages.

Fusion Bonded Epoxy Coated Valves

NOTICE

Valves with fusion bonded epoxy coated exterior paint require flat washers to be installed under the flange nuts when installing the valve to the pipeline flange to prevent the coating from cracking or chipping.

Maintenance

It is suggested that these valves, which do not require routine scheduled maintenance, be included as part of the normal facility equipment inspections for any malfunction while under normal usage conditions.

Shaft Packing Adjustment

Packing adjustment may be needed to optimize packing life on initial start-up.

▲WARNING

These valves may open or close, swinging the counterweight/spring lever arm without warning due to flow changes from pumps starting and stopping. Servicing or working around these valves while the pipeline is under pressure can cause personal injury or equipment damage.

Workers must be cautious when working around these valves. Relieve pipeline pressure and lockout the pumps before servicing the valve.

Tighten the gland nuts (A54) evenly only until the packing leak stops.

Caution: Do not over-tighten Packing Gland. Valve can remain open during operation if packing is too tight. After packing adjustments are made and pipeline is pressurized, visually inspect valve stroke to ensure proper operation.

Note: Do not continue tightening after leak stops. If packing leak cannot be stopped by tightening the gland nuts, the packing must be replaced.

Maintenance *(Continued)****Shaft Packing Replacement***

Removal of the valve from the line for shaft packing replacement is not required as long as the shaft is accessible.

▲WARNING

These valves may open or close, swinging the counterweight/spring loaded arm without warning due to flow changes from pumps starting and stopping. Servicing or working around these valves while the pipeline is under pressure can cause personal injury or equipment damage.

Workers must be cautious when working around these valves. Relieve pipeline pressure and lockout the pumps before servicing the valve.

1. Relieve the pressure in the pipeline and close the valve.
2. If needed, remove Counter Weight Arm Assembly (B19), Cushion Lever (B27). Then, remove the Packing Gland Nuts (A54), Washers (A50), and Packing Gland (A37) from Pivot Shaft (A13).
3. Remove the packing (A17) with a flexible packing hook or similar tool. Clean the packing area, being careful not to damage it.
4. Obtain the proper size packing from the parts list. Cut the packing rings to fit around the shaft. Install one ring at a time. Make sure it is clean and has not picked up any dirt in handling before installing it. Lubricate I.D. of each packing ring. Joints of successive rings should be staggered at least 90 degrees apart. Each ring should be firmly seated with a tamping tool. Do not depend on the packing gland entirely to seat the set of rings properly. This practice will jam the last rings installed but leave the first ones loose in the box.
5. See "Shaft Packing Adjustment" section to adjust packing after replacing.

Disc Seat Replacement**▲WARNING**

These valves may open or close, swinging the counterweight/spring loaded arm without warning due to flow changes from pumps starting and stopping. Servicing the valve while the pipeline is under pressure can cause personal injury or equipment damage.

Workers must be cautious when working around these valves. Relieve pipeline pressure and lockout the pumps before servicing the valve.

1. Relieve the pressure in the pipeline and close the valve. Lockout the pumps.
2. Remove Seat Retaining Ring (A31) from Disc (A10).
3. Remove old Disc Seat (A06) and replace with new Disc Seat.
4. Re-install Seat Retaining Ring (A31).

Maintenance *(Continued)****Changing Counterweight or Spring Assembly to Opposite Side of Valve*****▲WARNING**

These valves may open or close, swinging the counterweight/spring loaded arm without warning due to flow changes from pumps starting and stopping. Servicing or working around these valves while the pipeline is under pressure can cause personal injury or equipment damage.

Workers must be cautious when working around these valves. Relieve pipeline pressure and lockout the pumps before servicing the valve.

1. Relieve the pressure in the pipeline and close the valve. Lockout the pumps.
2. Loosen the Screw (B55) and remove the Counter Weight Arm (B19) and Weight (B29) assembly or Spring (B59) with Spring Bracket (B60). (Note that a special spring bracket may be required to change lever & spring assembly to opposite side of valve.)
3. If the valve is equipped with an Air Cylinder (B20):
 - a. Remove the Retaining Rings (B60) and Clevis Pin (B59) from the cylinder rod eye.
 - b. Remove the Cushion Cylinder (B20) and Bracket (B24) assembly from the Body (A01).
 - c. Remove the Cushion Lever (B27) from the Pivot Shaft (A13).
4. Remove the Packing Gland (A37), Packing (A17) and Studs (A49) from the Body (A01).
5. Remove the Screws (A16) and Pivot Shaft Cover (A15) from the Body (A01)
6. Remove the Eye Nuts (A64), Nuts (A52), Screws (A04), Washers (A51) and Cover (A02) from the Body (A01).
7. Loosen the Screws (A14) in the Disc Arm (A09).
8. Insert a threaded bolt (1/4-20) into the Pivot Shaft Retaining Pin (A60) and remove the pin from the pin hole in the top of the Body (A01).
9. Remove the Pivot Shaft (A13) from the Body (A01). The Packing (A17), Flanged Bushing (A12, on 4" and larger valves) and the Pivot Shaft Disc Key (A33) will be removed along with the shaft.
10. Remove the Straight Bushing (A11), on 4" and larger valves from the Body (A01) and install it on the opposite side of the body aligning it with the pin hole in the top of the body.
11. Align the Disc Arm (A09) with the holes in the Body (A01) for the Pivot Shaft (A13); insert the pivot shaft with the Pivot Shaft Disc Key (A33) with the groove and shorter keyway end first into the opposite side of the body, through the disc arm and align the pivot shaft retaining groove with the pin hole in the body.
12. Insert the Pivot Shaft Retaining Pin (A60) thru the hole in the top of the Body (A01) so the pin goes thru the Straight Bushing (A11), on 4" and larger valves in into the groove in the Pivot Shaft (A13). The pin should be flush with the top of the body.
13. Center the Disc (A10) assembly and the Body Seat (A05).
14. Tighten the Screws (A14) in the Disc Arm (A09).

Maintenance *(Continued)*

15. Slide the Flanged Bushing (A12), on 4" and larger valves over the Pivot Shaft (A13) and into the Body (A01).
16. Install one Packing Ring (A17) at a time. Make sure it is clean and has not picked up any dirt in handling before installing it. Lubricate I.D. of each packing ring. Joints of successive rings should be staggered at least 90 degrees apart. Each ring should be firmly seated with a tamping tool.
17. Install the Studs (A49), Packing Gland (A37), Washers (A50), Nuts (A54) and adjust packing.
18. Install the Pivot Shaft Cover (A15) with Screws (A16) and Washers (A50).
19. Install the Cover (A02) to the Body (A01) with Eye Nuts (A64), Nuts (A52), Screws (A04) and Washers (A51).
20. If the valve is equipped with an Air Cylinder (B20):
 - a. Install the Cushion Lever (B27) and Key (B34) on the Pivot Shaft (A13). Secure to Pivot Shaft by tightening Cushion Lever Screw.
 - b. Install the Cushion Cylinder (B20) and Bracket (B24) assembly to the Body (A01) using Hex Bolts (B21) and Washers (B22).
 - c. Install the Retaining Rings (B60) and Clevis Pin (B59) to secure the Cushion Arm to the cylinder rod eye.
21. Install Counter Weight Arm (B19) and Weight (B29) or Spring (B59) to the Pivot Shaft (A13). If equipped with lever & spring, install Spring Bracket (B60) assembly to Body (A01) using Spring Bracket Bolts (B62); then hook end of spring thru Eye Bolt (B61).

Adding Air Cushion Assembly to Valve

▲WARNING

These valves may open or close, swinging the counterweight/spring loaded arm without warning due to flow changes from pumps starting and stopping. Servicing or working around these valves while the pipeline is under pressure can cause personal injury or equipment damage.

Workers must be cautious when working around these valves. Relieve pipeline pressure and lockout the pumps before servicing the valve.

1. Relieve the pressure in the pipeline and close the valve. Lockout the pumps.
2. Loosen the Screw (B55) and remove the Counter Weight Arm (B19) and Weight (B29) assembly or Spring (B59) with Spring Bracket (B60). (Note that a special spring bracket is required to add an air cylinder to a lever & spring valve.)
3. If Clevis Pin (B59) is installed in cylinder rod eye, uninstall retaining rings (B60) and Clevis Pin
4. Install the Cushion Lever (B27) and Key (B34) on the Pivot Shaft (A13). Secure to Pivot Shaft by tightening Cushion Lever Screw.
5. Install the Cushion Cylinder (B20) and Bracket (B24) assembly to the Body (A01) using Hex Bolts (B21) and Washers (B22). If equipped with lever & spring, install Spring Bracket (B60) as shown on special assembly drawing provided.

Maintenance *(Continued)*

6. Install the Retaining Rings (B60) and Clevis Pin (B59) to secure the Cushion Arm to the cylinder rod eye.
7. Install Counter Weight Arm (B19) and Weight (B29) or Spring (B59) to the Pivot Shaft (A13). If equipped with lever & spring, then hook end of spring thru Eye Bolt (B61).

Operation

⚠WARNING

These valves may open or close, swinging the counterweight/spring loaded arm without warning due to flow changes from pumps starting and stopping. Servicing or working around these valves while the pipeline is under pressure can cause personal injury or equipment damage.

Workers must be cautious when working around these valves. Relieve pipeline pressure and lockout the pumps before servicing the valve.

The flow from the pump opens the Disc (A10) and raises the Counterweight Arm (B19). If the valve is equipped with an Air Cushion, the cylinder piston is pulled upward, drawing air freely into the cylinder through the small flow control valve. If the valve is equipped with a lever & spring, the spring (B59) is extended by the Lever Arm (B19) raising up.

When the pump is shut off, the decreased flow allows gravity to close the Disc (A10) towards the Body Seat Ring (A05). For valves equipped with a lever & weight, the weight causes the disc close faster or slower depending on its position along the lever. For valves equipped with an air cushion, the closure speed can be dampened by the air cylinder (B20). As the Disc (A10) closes, the cylinder piston is pushed downwards and the compressed air can only escape through the flow control valve on the bottom of the cylinder. The exhausting air can be adjusted with the flow control valve to suit the best performance for the installation. For valves equipped with a lever & spring, the stored energy in the extended spring (B59) causes the disc to close in addition to weight of the disc (A10).

System static pressure (downstream of the check valve) keeps the disc (A10) and disc seat (A06) closed and seated against the body seat (A05).

Closure Speed Control Adjustment (Valves with Lever & Weight)

- Faster Disc closing - Move Counterweight away from the pivot shaft.
- Slower Disc closing – Move Counterweight towards pivot shaft.

Closure Speed Control Adjustment (Valves with Air Cushion)

- Increase cushioning - Turn adjusting screw of Flow Control Valve clockwise.
- Decrease cushioning - Turn adjusting screw of Flow Control Valve counterclockwise
- Faster Disc closing - Move Counterweight away from the pivot shaft.
- Slower Disc closing – Move Counterweight towards pivot shaft.

Operation *(Continued)***Start-up Procedure**

1. Ensure the Counterweight Arm (B19) is angled 30° below the horizontal.
2. Throttle down mainline isolation valve (furnished by others) on discharge side of Swing Check Valve to approximately 1/3 open to prevent severe slamming during initial pump shutdown testing.
3. Position Counterweight (B29) midway on the lever and lock in place.
4. If valve has an Air Cushion: Turn adjusting screw of flow control valve two (2) turns counterclockwise from fully closed position.
5. Start and stop pump and observe rate of closing.

Adjustment (Valves with Air Cushion with Lever & Weight)

Condition	Adjustment
Check valve slams	Turn adjusting screw of Flow Control Valve one-half (1/2) turn clockwise. Repeat start and stop. If slam persists, continue turning adjusting screw in ½ turn increments. Be careful not to fully close Flow Control Valve.
Slam persists	Move weight towards end of lever a couple of inches. Repeat start and stop.
Slam still persists	Continue repeating above steps until satisfactory closing is achieved. Then increase opening discharge isolation valve to ½ open. Repeat start and stop pump sequence and above steps until isolation valve is full open.

Adjustment (Valves with Lever & Weight)

Condition	Adjustment
Check valve slams	Move weight towards end of lever a couple of inches. Repeat start and stop.
Slam persist	Repeat above step.

Notes:

1. Testing must be conducted carefully and adjustments made in small increments to arrive at the optimum where the swing check valve shuts off just prior to or at zero reverse flow.
2. The APCO CVS-250/250A Swing Check Valve is not a silent closing check valve.

Drawings

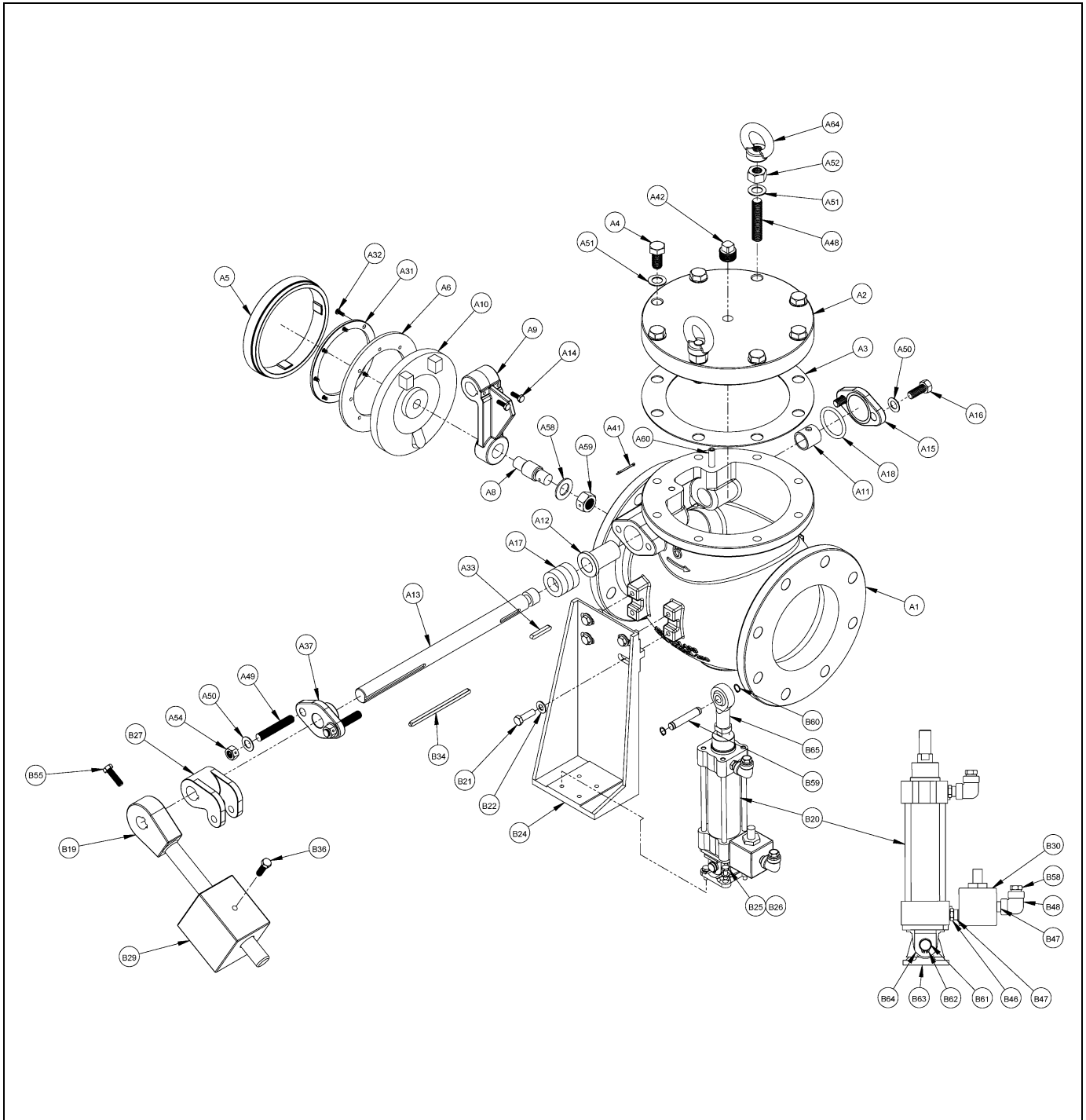

Figure 2 – APCO CVS-250/250A Swing Check Valve (with Air Cushion)

Drawings (Continued)

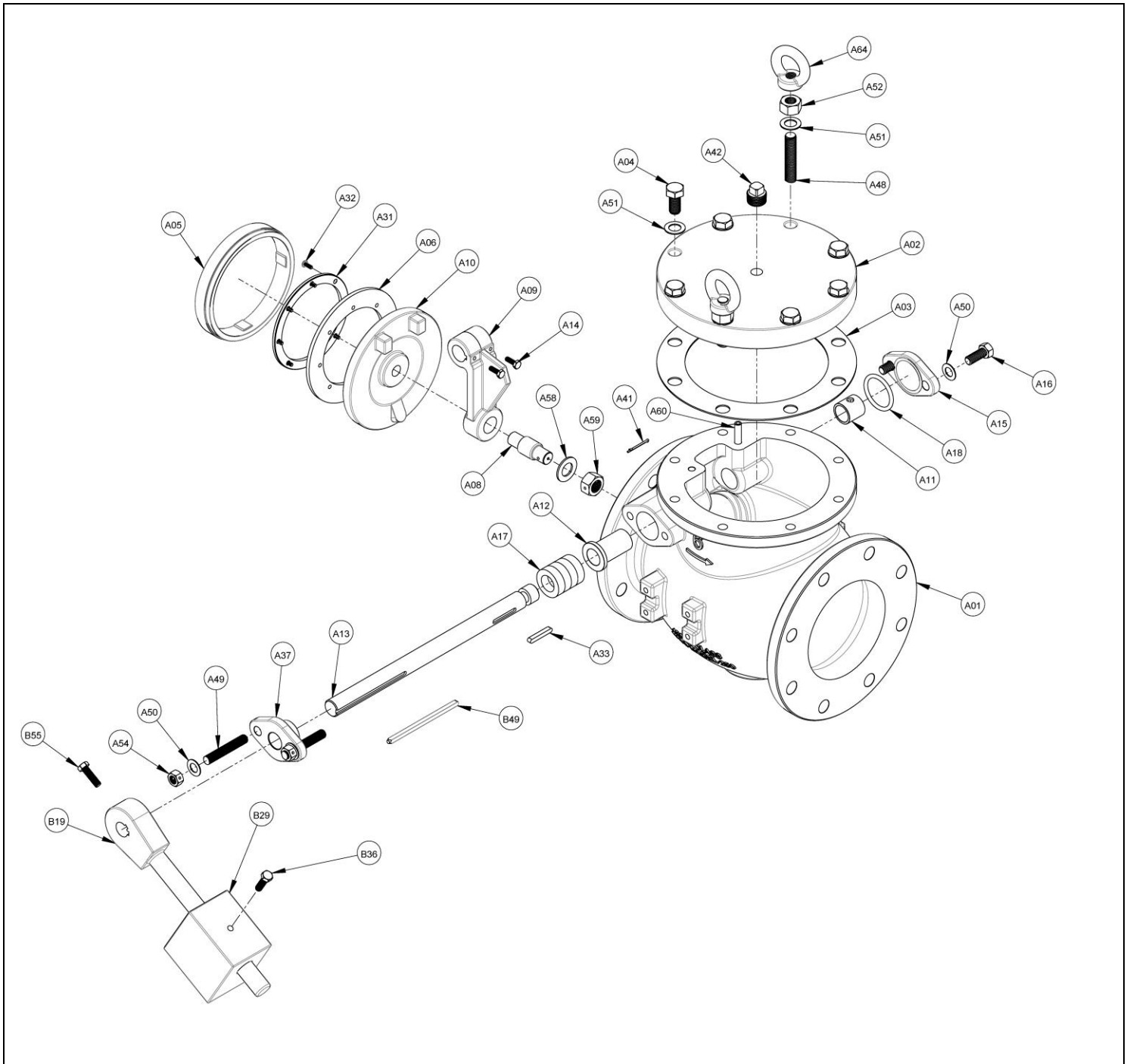

Figure 3 - CVS-250/250A Swing Check Valve (Lever & Weight)

Drawings (Continued)

Table 1 - CVS-250/250A Swing Check Valve Parts

Item Number	Description
A01	Body
A02	Cover
A03	Cover Gasket
A04	Hex Bolt
A05	Body Seat Ring
A06	Disc Seat
A08	Disc Stem
A09	Disc Arm
A10	Disc
A11	Straight Bushing
A12	Flanged Bushing
A13	Pivot Shaft
A14	Hex Bolt
A15	Pivot Shaft Cover
A16	Hex Bolt
A17	Packing
A18	Shaft Cover Seal
A31	Seat Retaining Ring
A32	Machine Screw
A33	Pivot Shaft Disc Key
A37	Packing Gland
A41	Cotter Pin
A42	Pipe Plug
A48	Stud
A49	Stud
A50	Washer
A51	Washer
A52	Hex Eye Nut
A54	Hex Nut
A58	Washer
A59	Hex Nut with Drilled Hole
A59	Spring
A60	Pivot Shaft Retaining Pin
A64	Eye Nut
A65	Cover Nut (30" & 36" only)

Note: Items A11 and A12 are not included in the 2" and 3" valve sizes.

Lever & Weight and Cylinder Parts

Item Number	Description
B19	Counter Weight Arm Assembly
B20	Cylinder Assembly (Air Cushion only)
B21	Hex Bolt (Air Cushion only)
B22	Washer (Air Cushion only)
B24	Cylinder Bracket (Air Cushion only)
B25	Hex Bolt
B26	Split Washer
B27	Cushion Lever (Air Cushion only)
B29	Counter Weight
B30	Flow Control Valve
B34	Pivot Shaft Key (Air Cushion only)
B36	Counterweight Arm Retaining Screw
B46	Reducer Bushing (8"-42")
B47	Pipe Nipple
B48	Pipe Elbow
B55	Lever Arm Bolt (Weighted Lever only)
B58	Air Breather
B59	Cushion Lever Clevis Pin (Air Cushion only)
B60	Retaining Ring (Air Cushion only)
B61	Clevis Pin (Air Cushion only)
B62	Retaining Ring (Air Cushion only)
B63	Male Clevis Bracket (Air Cushion only)
B64	Female Clevis Bracket (Air Cushion only)
B65	Yoke (Air Cushion only)

Note: Items B30, B46, B47, B48, B58, B61, B62, B63 & B64 are included with B20 Cylinder Assembly.

Drawings (Continued)

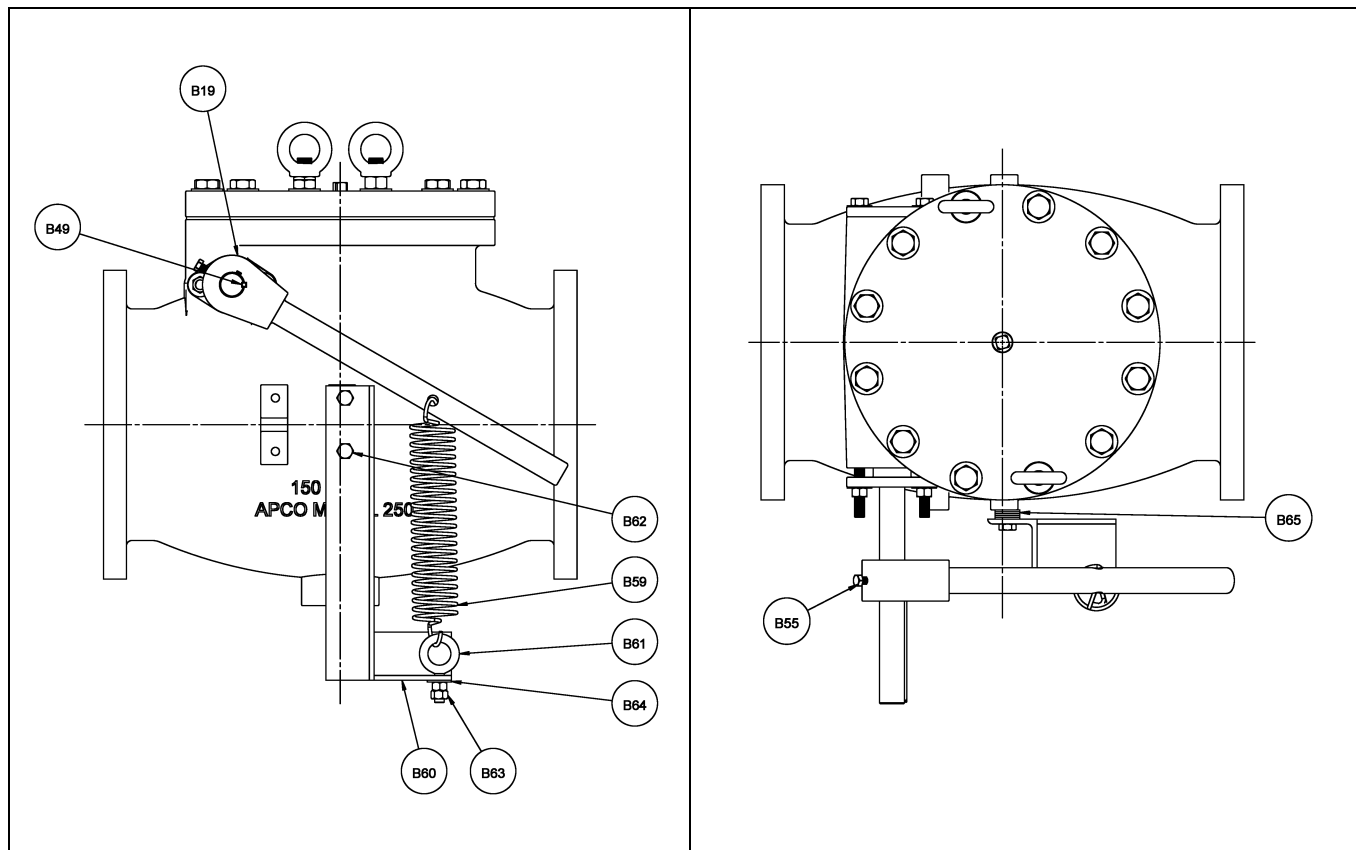

Figure 4 - CVS-250/250A Swing Check Valve (Lever & Spring)

Table 2 –Lever & Spring Parts

Item Number	Description
B19	Lever Arm (Spring Only)
B49	Spring Lever Arm Key (Spring Only)
B55	Spring Lever Arm Retainer Screw (Spring Only)
B59	Spring (Spring Only)
B60	Spring Bracket (Spring Only)
B61	Eye Bolt (Spring Only)
B62	Spring Bracket Bolt (Spring Only)
B63	Eye Bolt Retaining Nut (Spring Only)
B64	Spring Bracket Washer (Spring Only)
B65	Washer (Spring Only)

Troubleshooting

Condition	Possible Cause	Corrective Action
Shaft seal leaks.	Packing is worn. Packing is not tight.	Replace Packing. Adjust packing.
Valve leaks excessively from one side of the disc to the other.	Foreign matter caught between disc and seat.	Fully open valve to remove object.
	Disc seat is worn or damaged.	Repair disc seat or replace valve.
Valve leaks at flange joint.	Loose flange bolting.	Tighten flange bolting.
	Blown flange gasket.	Replace flange gasket.
	Misalignment or damage to field piping and supports.	Adjust misalignment or repair piping or supports.
	Damaged flange face/s or improper flange connections.	Repair flange, replace valve body or adjust flange connections.
Valve does not fully close.	Object is wedged between seat and disc.	Fully open valve to remove object.
	Packing Gland is too tight	Loosen packing gland fasteners. Packing may need to be replaced if leakage occurs.

Limited Warranty

DeZURIK, Inc. ("Seller") manufactured products, auxiliaries and parts thereof that we manufacture for a period of twenty-four (24) months from date of shipment from Seller's factory, are warranted to the original purchaser only against defective workmanship and material, but only if properly stored, installed, operated, and serviced in accordance with Seller's recommendations and instructions.

For items proven to be defective within the warranty period, your exclusive remedy under this limited warranty is repair or replacement of the defective item, at Seller's option, FCA Incoterms 2020 Seller's facility with removal, transportation, and installation at your cost.

Products or parts manufactured by others but furnished by Seller are not covered by this limited warranty. Seller may provide repair or replacement for other's products or parts only to the extent provided in and honored by the original manufacturer's warranty to Seller, in each case subject to the limitations contained in the original manufacturer's warranty.

No claim for transportation, labor, or special or consequential damages or any other loss, cost or damage is being provided in this limited warranty. You shall be solely responsible for determining suitability for use and in no event shall Seller be liable in this respect.

This limited warranty does not warrant that any Seller product or part is resistant to corrosion, erosion, abrasion or other sources of failure, nor does Seller warrant a minimum length of service.

Your failure to give written notice to us of any alleged defect under this warranty within twenty (20) days of its discovery, or attempts by someone other than Seller or its authorized representatives to remedy the alleged defects therein, or failure to return product or parts for repair or replacement as herein provided, or failure to store, install, or operate said products and parts according to the recommendations and instructions furnished by Seller shall be a waiver by you of all rights under this limited warranty.

This limited warranty is voided by any misuse, modification, abuse or alteration of Seller's product or part, accident, fire, flood or other Act of God, or your failure to pay entire contract price when due.

The foregoing limited warranty shall be null and void if, after shipment from our factory, the item is modified in any way or a component of another manufacturer, such as but not limited to; an actuator is attached to the item by anyone other than a Seller factory authorized service personnel.

All orders accepted shall be deemed accepted subject to this limited warranty, which shall be exclusive of any other or previous warranty, and this shall be the only effective guarantee or warranty binding on Seller, despite anything to the contrary contained in the purchase order or represented by any agent or employee of Seller in writing or otherwise, notwithstanding, including but not limited to implied warranties.

THE FOREGOING REPAIR AND REPLACEMENT LIMITED WARRANTY IS IN LIEU OF ALL OTHER WARRANTIES, OBLIGATIONS AND LIABILITIES, INCLUDING, BUT NOT LIMITED TO, ALL WARRANTIES OF FITNESS FOR A PARTICULAR PURPOSE OR OF MERCHANTABILITY OR OTHERWISE, EXPRESSED OR IMPLIED IN FACT OR BY LAW, AND STATE SELLER'S ENTIRE AND EXCLUSIVE LIABILITY AND YOUR EXCLUSIVE REMEDY FOR ANY CLAIM IN CONNECTION WITH THE SALE AND FURNISHING OF SERVICES, GOODS OR PARTS, THEIR DESIGN, SUITABILITY FOR USE, INSTALLATION OR OPERATIONS. NEITHER ANY PERFORMANCE OR OTHER CONDUCT, NOR ANY ORAL OR WRITTEN INFORMATION, STATEMENT, OR ADVICE PREPARED BY SELLER OR ANY OF OUR EMPLOYEES OR AGENTS WILL CREATE A WARRANTY, OR IN ANY WAY INCREASE THE SCOPE OR DURATION OF THE LIMITED WARRANTY.

Disclaimer

Metric fasteners should not be used with ASME Class 150/300 bolt holes and flange bolt patterns. If you use metric fasteners with ASME Class 150/300 bolt holes and flange bolt patterns, it may lead to product failure, injury, and loss of life. DeZURIK Inc. disclaims all liability associated with the use of metric fasteners with ASME Class 150/300 bolt holes and flange patterns, including but not limited to personal injury, loss of life, loss of product, production time, equipment, property damage, lost profits, consequential damages of any kind and environment damage and/or cleanup. Use of metric fasteners with ASME Class 150/300 bolt holes and flange bolt patterns is a misuse that voids all warranties and contractual assurances. If you use metric fasteners with ASME Class 150/300 bolt holes and flange bolt patterns, you do so at your sole risk and any liability associated with such use shall not be the responsibility of DeZURIK, Inc. In addition to the foregoing, DeZURIK's Manufacturer's Conditions apply.

Limitation of Liability

IN NO EVENT SHALL SELLER BE LIABLE FOR ANY DIRECT, INDIRECT, SPECIAL, PUNITIVE, EXEMPLARY, OR CONSEQUENTIAL DAMAGES (INCLUDING, BUT NOT LIMITED TO; DAMAGE TO OR LOSS OF OTHER PROPERTY OR EQUIPMENT, BUSINESS INTERRUPTION, COST OF SUBSTITUTE PRODUCTS, LOSS OF TIME, LOSS OF PROFITS OR REVENUE, COST OF CAPTIAL, LOSS OF USE, OR DIMINUTION IN VALUE) WHATSOEVER, AND SELLER'S LIABILITY, UNDER NO CIRCUMSTANCES, WILL EXCEED THE CONTRACT PRICE FOR THE GOODS AND/OR SERVICES FOR WHICH LIABILITY IS CLAIMED. ANY ACTION FOR BREACH OF CONTRACT BY YOU, OTHER THAN RIGHTS RESPECTING OUR LIMITED WARRANTY DESCRIBED ABOVE, MUST BE COMMENCED WITHIN 12 MONTHS AFTER THE DATE OF SALE.

Sales and Service

For information about our worldwide locations, approvals, certifications and local representative:

Web site: www.dezurik.com E-Mail: info@dezurik.com



250 Riverside Ave. N., Sartell, MN 56377 • Phone: 320-259-2000 • Fax: 320-259-2227

DeZURIK, Inc. reserves the right to incorporate our latest design and material changes without notice or obligation.

Design features, materials of construction and dimensional data, as described in this manual, are provided for your information only and should not be relied upon unless confirmed in writing by DeZURIK, Inc. Certified drawings are available upon request.