

APCO CVS-EDV SWING CHECK VALVES



Instruction **D12042**
March 2023

Instructions

These instructions are for use by personnel who are responsible for the installation, operation and maintenance of DeZURIK valves, actuators or accessories.

Safety Messages

All safety messages in the instructions are identified by a general warning sign and the signal word CAUTION, WARNING or DANGER. These messages indicate procedures to avoid injury or death.

Safety label(s) on the product indicate hazards that can cause injury or death. If a safety label becomes difficult to see or read, or if a label has been removed, please contact DeZURIK for replacement label(s).

⚠WARNING

Personnel involved in the installation or maintenance of valves should be constantly alert to potential emission of pipeline material and take appropriate safety precautions. Always wear suitable protection when dealing with hazardous pipeline materials. Handle valves which have been removed from service with suitable protection for any potential pipeline material in the valve.

Inspection

Your DeZURIK product has been packaged to provide protection during shipment; however, items can be damaged in transport. Carefully inspect the unit for damage upon arrival and file a claim with the carrier if damage is apparent.

Parts

Replaceable wear parts are listed on the assembly drawing. These parts can be stocked to minimize downtime. Order parts from your local DeZURIK sales representative or directly from DeZURIK. When ordering parts please provide the following information:

If the valve has a data plate: please include the 7-digit part number with either 4-digit revision number (example: 9999999R000) or 8-digit serial number (example: S1900001) whichever is applicable. The data plate will be attached to the valve assembly. Also, include the part name, the assembly drawing number, the balloon number and the quantity stated on the assembly drawing.

If there isn't any data plate visible on the valve: please include valve model number, part name, and item number from the assembly drawing. You may contact your local DeZURIK Representative to help you identify your valve.

DeZURIK Service

DeZURIK service personnel are available to maintain and repair all DeZURIK products. DeZURIK also offers customized training programs and consultation services. For more information, contact your local DeZURIK sales representative or visit our website at DeZURIK.com.

Table of Contents

Description	4
Handling and Storage	4
Installation.....	4
Fusion Bonded Epoxy Coated Valves.....	5
Maintenance	6
Shaft Packing Adjustment	6
Shaft Packing Replacement	6
Disc Seat Replacement	6
Changing Counterweight or Spring Assembly to Opposite Side of Valve.....	7
Adding Air Cushion Assembly to Valve	8
Closure Speed Control Adjustment (Valves with Lever & Weight)	9
Closure Speed Control Adjustment (Valves with Air Cushion)	9
Start-up Procedure	9
Adjustment (Valves with Air Cushion with Lever & Weight).....	10
Adjustment (Valves with Lever & Weight).....	10
Drawings	11
Figure 3 – APCO CVS-EDV Swing Check Valve	11
Figure 5 - CVS-EDV Swing Check Valve (Air Cushion)	13
Troubleshooting	17

Description

A swing check valve consists of a valve body, a cover, and a disc that is connected to a hinge. The disc swings away from the valve-seat to allow flow in the forward direction, and returns to valve-seat when upstream flow is stopped, to prevent backflow. The valve is equipped with either a lever & weight, an air cushion with lever & weight, or a lever & spring to assist with closing the valve.

Handling and Storage

Lifting the valve improperly may damage it. Do not fasten lifting devices to the actuator or through the seat opening in the body. Lift the valve with slings, chains or cables fastened around the valve body, or fastened to bolts or rods through bolt holes in the flanges.

If installation will be delayed, place valve indoors in secure, weather tight storage. If temporary outside storage is unavoidable, make sure a vermin proof rain cover (water shedding tarp, etc.) is secured around/over the equipment to keep off rain and mud. Skid and set the assembly on a flat, solid, and well drained surface for protection from ground moisture, runoff and pooled rain water.

Installation

- The APCO CVS-EDV Swing Check Valve may be installed in a horizontal or vertical position (with the flow upward). In either case, the Counterweight Arm should be set in horizontal position. Unless otherwise specified, the valves are shipped for horizontal installation.
 - See Figure 3 and 4 for component identification. On Lever and weight valves, to change the counterweight arm position from horizontal to vertical installation, unscrew Lever Arm to Shaft Set Screw (B57), remove Counterweight Lever Arm Washer (B56), loosen the Lever Weight Assembly Set Screw (B55), slide the counterweight arm assembly off the Shaft (A13), rotate the counterweight arm assembly and slide it back onto the Shaft (A13) using the appropriate keyway shown in Figure 1.

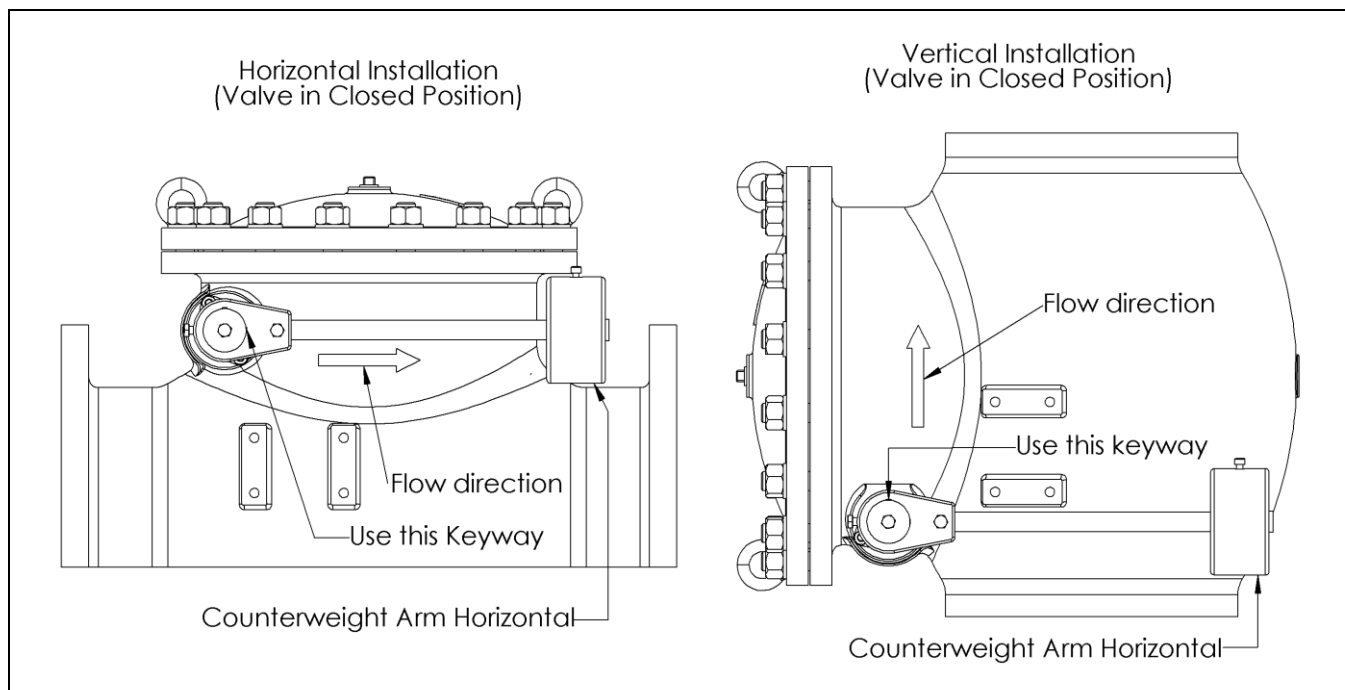

Figure 1 – Counterweight Arm Position

Installation *(Continued)*

- Before installation, remove foreign material such as weld spatter, oil, grease, and dirt from the pipeline.

NOTICE

The recommendation by Manufacturers Standardization Society of the Valve and Fittings Industry (MSS SP- 92) is to install a check valve at a minimum of 10 pipe diameters of straight pipe on the downstream side from tees, fittings, increasers, or pumps and 5 pipe diameters from elbows to ensure laminar flow with minimum turbulence to minimize disc movement and premature wear. However, many facilities with smaller footprints have achieved acceptable performance in systems with the check valve installed 5 pipe diameter lengths of straight pipe from the downstream side of tees, fittings, increasers, or pumps and 3 pipe diameters lengths from elbows.

- Prepare pipe ends and install valves in accordance with the pipe manufacturer's instructions for the joint used.

NOTICE

Do not deflect the pipe-valve joint. Minimize bending stresses in the valve end connection with pipe loading.

If excessive seat leakage occurs during start-up, recheck the installation and eliminate any distortion to the valve body.

- Ensure the valve and pipeline flanges are concentric to ensure proper flange sealing and seat leakage control.
- Tighten the flange bolts or studs in a crisscross pattern a minimum of four stages.

Fusion Bonded Epoxy Coated Valves**NOTICE**

Valves with fusion bonded epoxy coated exterior paint require flat washers to be installed under the flange nuts when installing the valve to the pipeline flange to prevent the coating from cracking or chipping.

Maintenance

It is suggested that these valves, which do not require routine scheduled maintenance, be included as part of the normal facility equipment inspections for any malfunction while under normal usage conditions.

Shaft Packing Adjustment

Packing adjustment may be needed to optimize packing life on initial start-up.

▲WARNING

These valves may open or close, swinging the counterweight/spring lever arm without warning due to flow changes from pumps starting and stopping. Servicing or working around these valves while the pipeline is under pressure can cause personal injury or equipment damage. Workers must be cautious when working around these valves. Relieve pipeline pressure and lockout the pumps before servicing the valve.

Tighten the Gland Nuts (A26) (see Figure 3) evenly only until the packing leak stops.

Caution: Do not over-tighten Packing Gland. Valve can remain open during operation if packing is too tight. After packing adjustments are made and pipeline is pressurized, visually inspect valve stroke to ensure proper operation.

Note: Do not continue tightening after leak stops. If packing leak cannot be stopped by tightening the gland nuts, the packing must be replaced.

Shaft Packing Replacement

Removal of the valve from the line for shaft packing replacement is not required as long as the shaft is accessible.

1. Relieve the pressure in the pipeline and close the valve.
2. If needed, remove Counterweight Lever Arm Fabrication (B54), spring Lever Arm Fabrication (B33 or B85) or Cushion Lever (B88). Then, remove the Gland Nuts (A26) and Gland (A25) from Shaft (A13).
3. Remove Long Flat Key (B78) from extended shaft.
4. Remove the V-Type Packing Sets (A23) with a flexible packing hook or similar tool. Clean the packing area, being careful not to damage it.
5. Obtain the proper size packing from the parts list. Cut the packing rings to fit around the shaft. Install one ring at a time. Make sure it is clean and has not picked up any dirt in handling before installing it. Lubricate I.D. of each packing ring. Each ring should be firmly seated with a tamping tool. Do not depend on the packing gland entirely to seat the set of rings properly. This practice will jam the last rings installed but leave the first ones loose in the box.
6. See "Shaft Packing Adjustment" section to adjust packing after replacing.

Disc Seat Replacement

▲WARNING

Servicing the valve while the pipeline is under pressure can cause personal injury or equipment damage. Relieve pipeline pressure before servicing the valve.

1. Relieve the pressure in the pipeline and close the valve.
2. Remove Seat Retaining Ring (A16) from Disc (A10).
3. Remove old Disc Seat (A15) and replace with new Disc Seat.
4. Re-install Seat Retaining Ring (A16).

Maintenance *(Continued)****Changing Counterweight or Spring Assembly to Opposite Side of Valve*****⚠WARNING**

Servicing the valve while the pipeline is under pressure can cause personal injury or equipment damage. Relieve pipeline pressure before servicing the valve.

1. Relieve the pressure in the pipeline and close the valve.
2. Unscrew Lever Arm to Shaft Set Screw (B57). Remove Counterweight Lever Arm Washer (B56). Loosen the Lever Weight Assy Set Screw (B55) and remove the counterweight assembly, or loosen Spring Lever Arm Retention Screw (B31 or B87) and remove spring assembly with Spring Bracket (B32) or Spring Cylinder (B83). (Note that a special spring bracket or cylinder may be required to change lever & spring assembly to opposite side of valve.)
3. If the valve is equipped with a Pneumatic Cylinder (B68):
 - a. Remove the Cushion Lever Clevis Pin Retaining Ring (B62) and Cushion Lever Clevis Pin (B61) from the Y-Connector (B63) eye.
 - b. Remove the Pneumatic Cylinder assembly (B68) and Cylinder Bracket (B66) from the Body (A1).
 - c. Loosen AC Assy Set Screw (B76) and remove the Cushion Lever (B88) from the Shaft (A13).
4. Remove Long Flat Key (B78).
5. Loosen and remove Cover Nuts (A28) and Cover Nut Washers (A29). Remove Cover (A2).
6. Loosen and remove Limit Screw (A11).
7. From the extended shaft side of the valve, loosen and remove Gland Nuts (A26), remove the Gland (A25), V-Type Packing set (A23) and Filler Ring (A21) from the Body (A1). Repeat process on side opposite extended shaft.
8. Remove the Shaft (A13) along with Key (A8) from the Body (A1).
9. Flip and insert Shaft (A13) along with Key (A8) positioned in slot into shaft opening on opposite side of Body (A1). Key must align with slot in Disc Arm (A9).
10. Install Filler Ring (A21) over extended Shaft (A13) flush into Body (A1) recess. Install V-Type Packing (A23) pieces one at a time with flat face of first piece flush against Filler Ring (A21). Follow insertion of the first 3 packing pieces with cap piece of the V-Type Packing set. Make sure all pieces are clean and have not picked up any dirt in handling before installing it. Lubricate I.D. of each piece. Each piece should be firmly seated with a tamping tool. Install the Gland (A25), and Gland Nuts (A26) loosely. Repeat process on opposite side of valve.
11. Install Limit Screw (A11) in Body (A1) hole above receiving notch in Shaft (A13). Adjust V-Type Packing Sets (A23) and tighten Gland Nuts (A26) on both sides.
12. Install the Cover (A2) to the Body (A1) with Cover Nuts (A28) and Cover Nut Washers (A29).
13. Insert Long Flat Key (B78) into slot at end of Shaft (A13).

14. If the valve is equipped with a Pneumatic Cylinder (B68):
 - a. Install the Cushion Lever (B88) onto the Shaft (A13).
 - b. Install the Pneumatic Cylinder assembly (B68) and Cylinder Bracket (B66) onto the Body (A1) using Cylinder Bracket Mounting Bolts (B69).
 - c. Slide Cushion Lever (B88) into Y-Connector (B63). Install the Cushion Lever Clevis Pin (B61) into the Y-Connector (B63) eye. Secure with Cushion Lever Clevis Pin Retaining Ring (B62). Tighten AC Assy Set Screw (B76).
15. Install counterweight assembly by sliding Counterweight Lever Arm Fabrication (B54) onto Shaft (A13) and tightening Lever Weight Assy Set Screw (B55), or install spring lever assembly by sliding Lever Arm Fabrication (B33 or B85) onto the Shaft (A13) and tightening Spring Lever Arm Ret. Screw 3-14" (B31) or Spring Lever Arm Ret. Screw 16-30" (B87). On sizes 3-14", install Spring Bracket (B32) to Body (A1). On sizes 16-30", install Spring Cylinder (B83) to Body (A1). Secure using Spring Bracket Screws (B38) or Spring Cylinder Mount Bolts (B84). On size 3-14", hook ends of Spring (B34) thru Eye Bolt (B35) and Lever Arm Fabrication 3-14" (B33).
16. Position Counterweight Lever Arm Washer (B56) at end of Shaft (A13). Insert Lever Arm to Shaft Set Screw (B57) and tighten.

Adding Air Cushion Assembly to Valve

▲WARNING

Servicing the valve while the pipeline is under pressure can cause personal injury or equipment damage. Relieve pipeline pressure before servicing the valve.

1. Relieve the pressure in the pipeline and close the valve.
2. Unscrew Lever Arm to Shaft Set Screw (B57). Remove Counterweight Lever Arm Washer (B56). Loosen the Lever Weight Assy Set Screw (B55) and remove the counterweight assembly.
3. Install the Cushion Lever (B88) onto the Shaft (A13).
4. Install the Pneumatic Cylinder assembly (B68) and Cylinder Bracket (B66) onto the Body (A1) using Cylinder Bracket Mounting Bolts (B69).
5. Slide Cushion Lever (B88) into Y-Connector (B63). Install the Cushion Lever Clevis Pin (B61) into the Y-Connector (B63) eye. Secure with Cushion Lever Clevis Pin Retaining Ring (B62). Tighten AC Assy Set Screw (B76).
6. Install counterweight assembly by sliding Counterweight Lever Arm Fabrication (B54) onto Shaft (A13) and tightening Lever Weight Assy Set Screw (B55).

Operation

The flow from the pump opens the Disc (A10) and raises the counterweight assembly. If the valve is equipped with an air cushion, the cylinder piston is pulled upward, drawing air freely into the Pneumatic Cylinder (B68) through the Flow Control Valve (B67). If the 3-14" valve is equipped with a lever & spring, the spring (B34) is extended by the Lever Arm Fabrication (B33) raising up. If the 16-30" valve is equipped with a lever & spring, the spring (B86) is compressed by the Lever Arm Fabrication (B85) raising up, lifting the Spring Shaft (B39), which in turn pulls the Spring Tension Plate (B79) which the Spring (B86) is seated on.

When the pump is shut off, the decreased flow allows gravity to close the Disc (A10) towards the Body Seat Ring (A5). For valves equipped with a lever & weight, the Counterweight (B60) causes the Disc (A10) to close faster or slower depending on its position along the Counterweight Arm (B59). For valves equipped with an air cushion, the closure speed can be dampened by the Pneumatic Cylinder (B68). As the Disc (A10) closes, the cylinder piston is pushed downwards and the compressed air can only escape through the Flow Control Valve (B67) on the bottom of the cylinder. The exhausting air can be adjusted with the Flow Control Valve (B67) to suit the best performance for the installation. For 3-14" valves equipped with a lever & spring, the stored energy in the extended spring (B34) causes the Disc (A10) to close in addition to weight of the disc. For 16-30" valves equipped with a lever & spring, the stored energy in the compressed spring (B86) causes the Disc (A10) to close in addition to weight of the disc.

System static pressure (downstream of the swing check valve) keeps the Disc (A10) and Disc Seat (A15) closed and seated against the Body Seat Ring (A5).

Closure Speed Control Adjustment (Valves with Lever & Weight)

- Faster Disc closing - Move Counterweight (B60) away from the Shaft (A13).
- Slower Disc closing – Move Counterweight (B60) towards Shaft (A13).

Closure Speed Control Adjustment (Valves with Air Cushion)

- Increase cushioning - Turn adjusting screw of Flow Control Valve (B67) clockwise.
- Decrease cushioning - Turn adjusting screw of Flow Control Valve (B67) counterclockwise.

Start-up Procedure

1. Ensure the Counterweight Arm (B59) is horizontal.
2. Throttle down mainline isolation valve (furnished by others) on discharge side of Swing Check Valve to approximately 1/3 open to prevent severe slamming during initial pump shutdown testing.
3. Position Counterweight (B60) midway on the lever and lock in place.
4. If valve has an Air Cushion: Unlock Flow Control Valve by turning Flow Control Valve lock nut counterclockwise. Turn Flow Control Valve adjustment screw two (2) turns counterclockwise from fully close position. Lock Flow Control Valve by turning Flow Control Valve lock nut clockwise. (See Figure 2.)
5. Start and stop pump and observe rate of closing.

Operation (Continued)

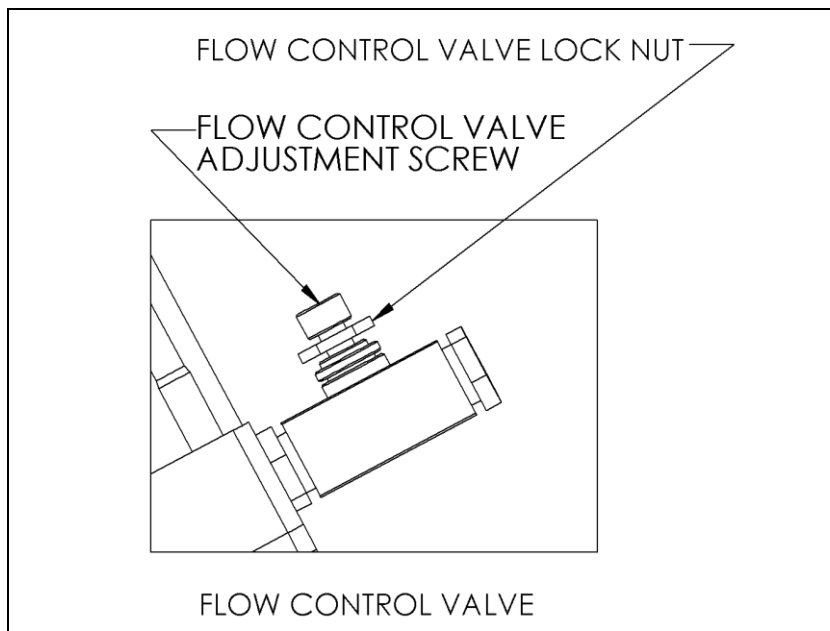

Figure 2 – Adjustable Flow Control Valve

Adjustment (Valves with Air Cushion with Lever & Weight)

Condition	Adjustment
Check valve slams	Unlock Flow Control Valve by turning valve lock nut counter-clockwise. Turn adjustment screw of Flow Control Valve one-half (1/2) turn clockwise. Repeat start and stop. If slam persists, continue turning adjustment screw in 1/2 turn increments. Be careful not to fully close Flow Control Valve. Lock Flow Control Valve when finished.
Slam persists	Move weight towards end of lever a couple of inches. Repeat start and stop.
Slam still persists	Continue repeating above steps until satisfactory closing is achieved. Then increase opening discharge isolation valve to 1/2 open. Repeat start and stop pump sequence and above steps until isolation valve is full open. Lock Flow Control Valve when finished.

Adjustment (Valves with Lever & Weight)

Condition	Adjustment
Check valve slams	Move weight towards end of lever a couple of inches. Repeat start and stop.
Slam persist	Repeat above step.

Notes:

1. Testing must be conducted carefully and adjustments made in small increments to arrive at the optimum setting where the swing check valve shuts off just prior to or at zero reverse flow.
2. The APCO CVS-EDV Swing Check Valve is not a silent closing check valve.

Drawings

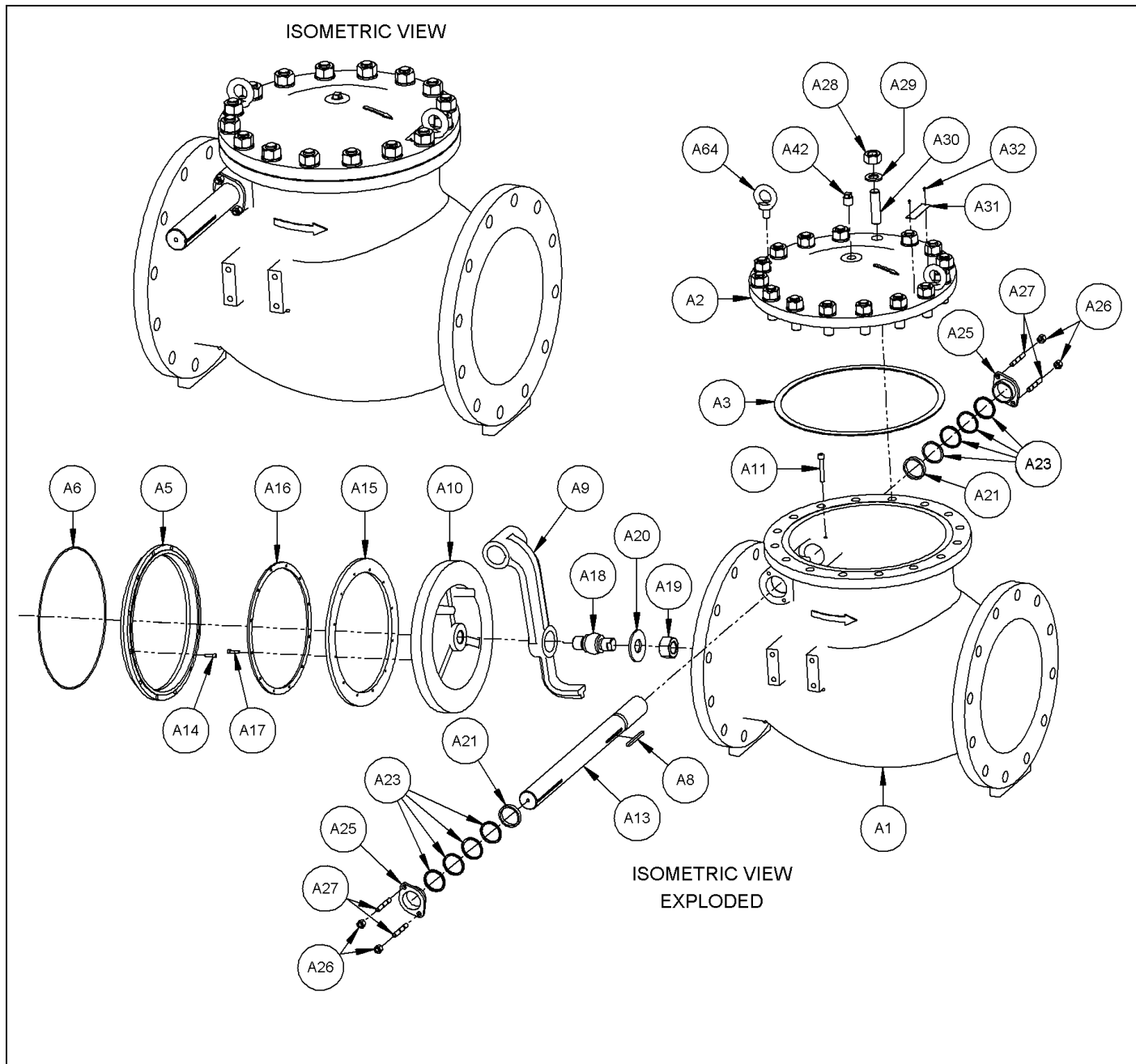

Figure 3 – APCO CVS-EDV Swing Check Valve

Drawings (Continued)

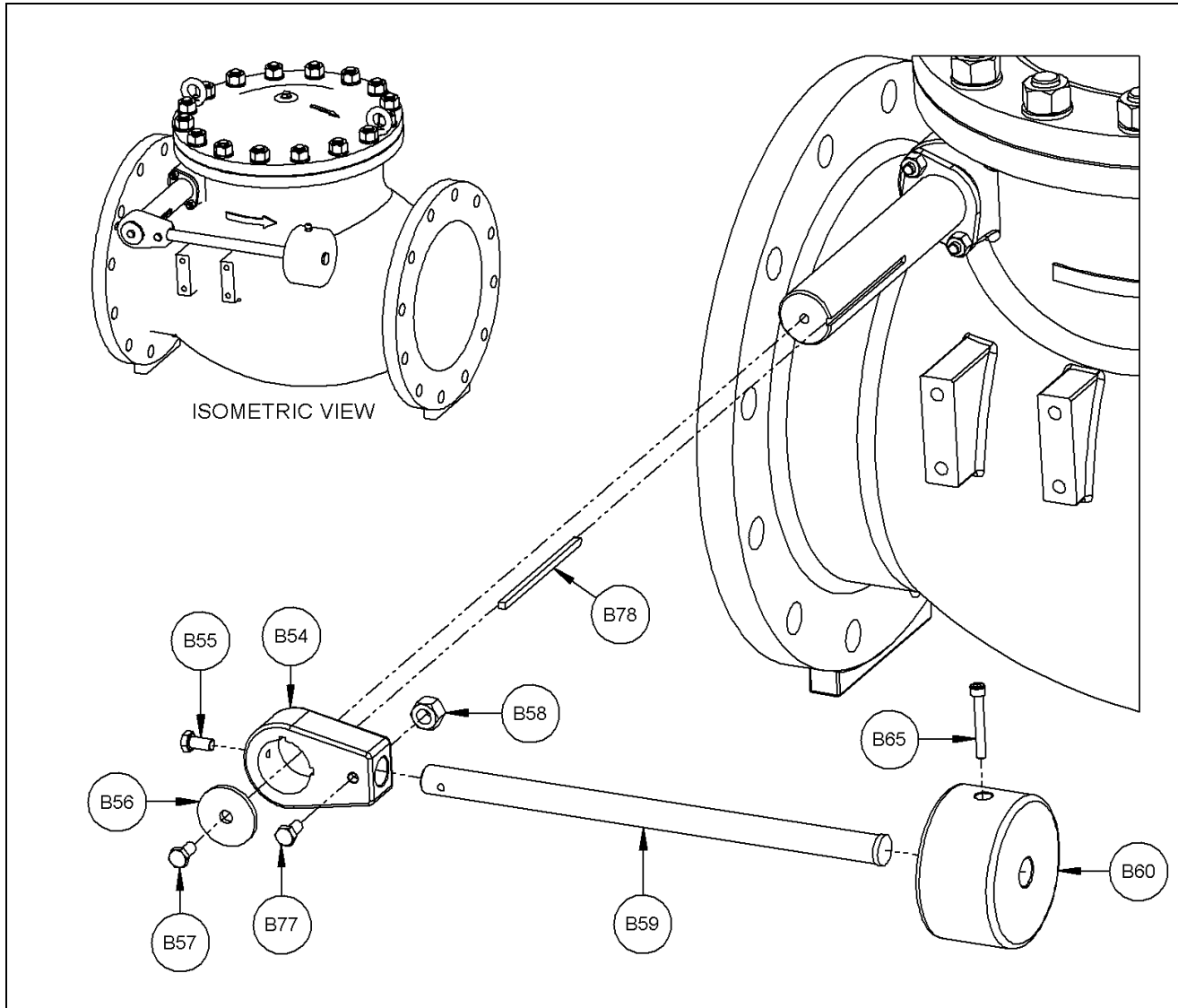

Figure 4 - CVS-EDV Swing Check Valve (Lever & Weight)

Drawings (Continued)

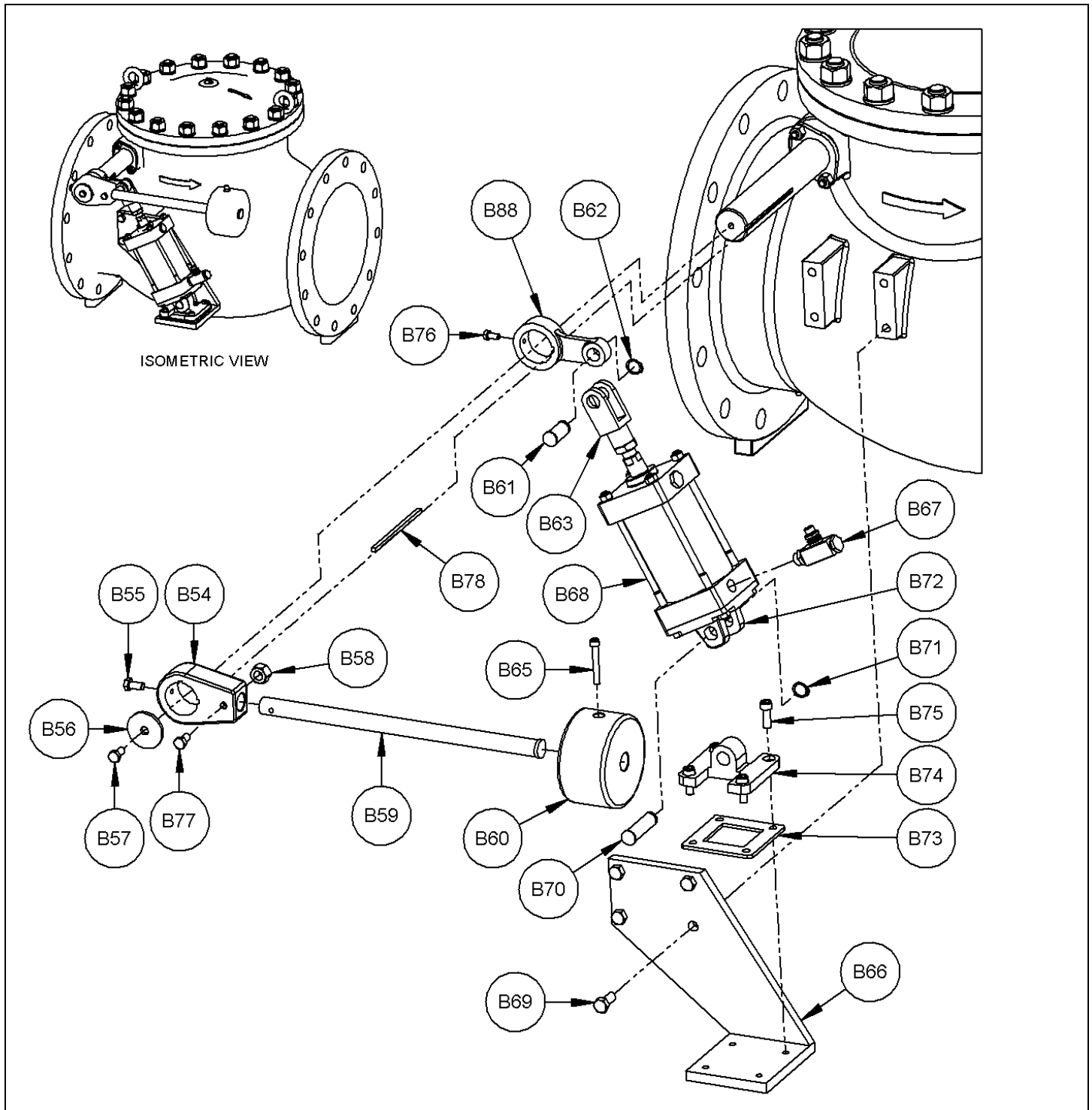

Figure 5 - CVS-EDV Swing Check Valve (Air Cushion)

Drawings (Continued)

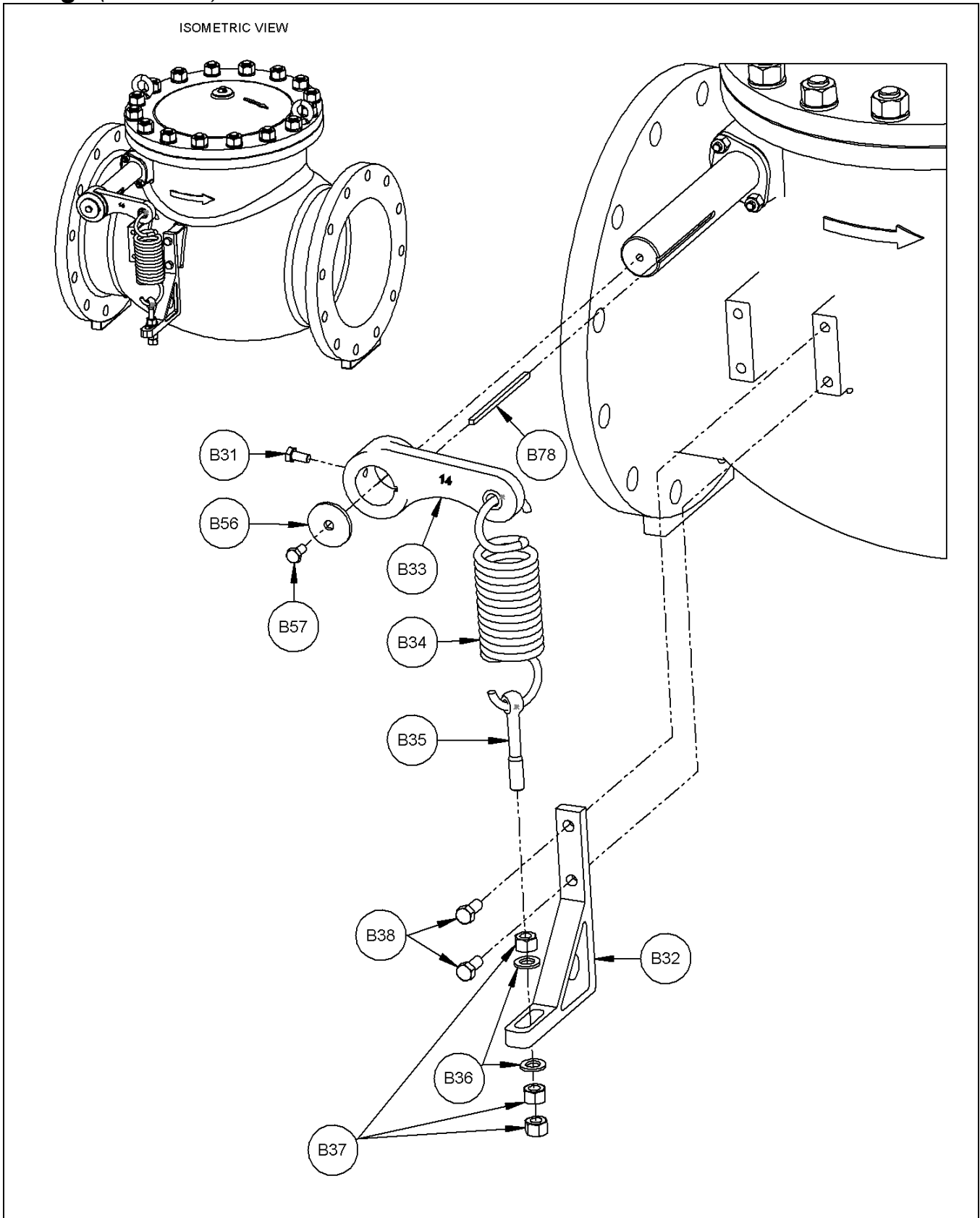

Figure 6 - CVS-EDV Swing Check Valve (Lever & Spring 3-14")

Drawings (Continued)

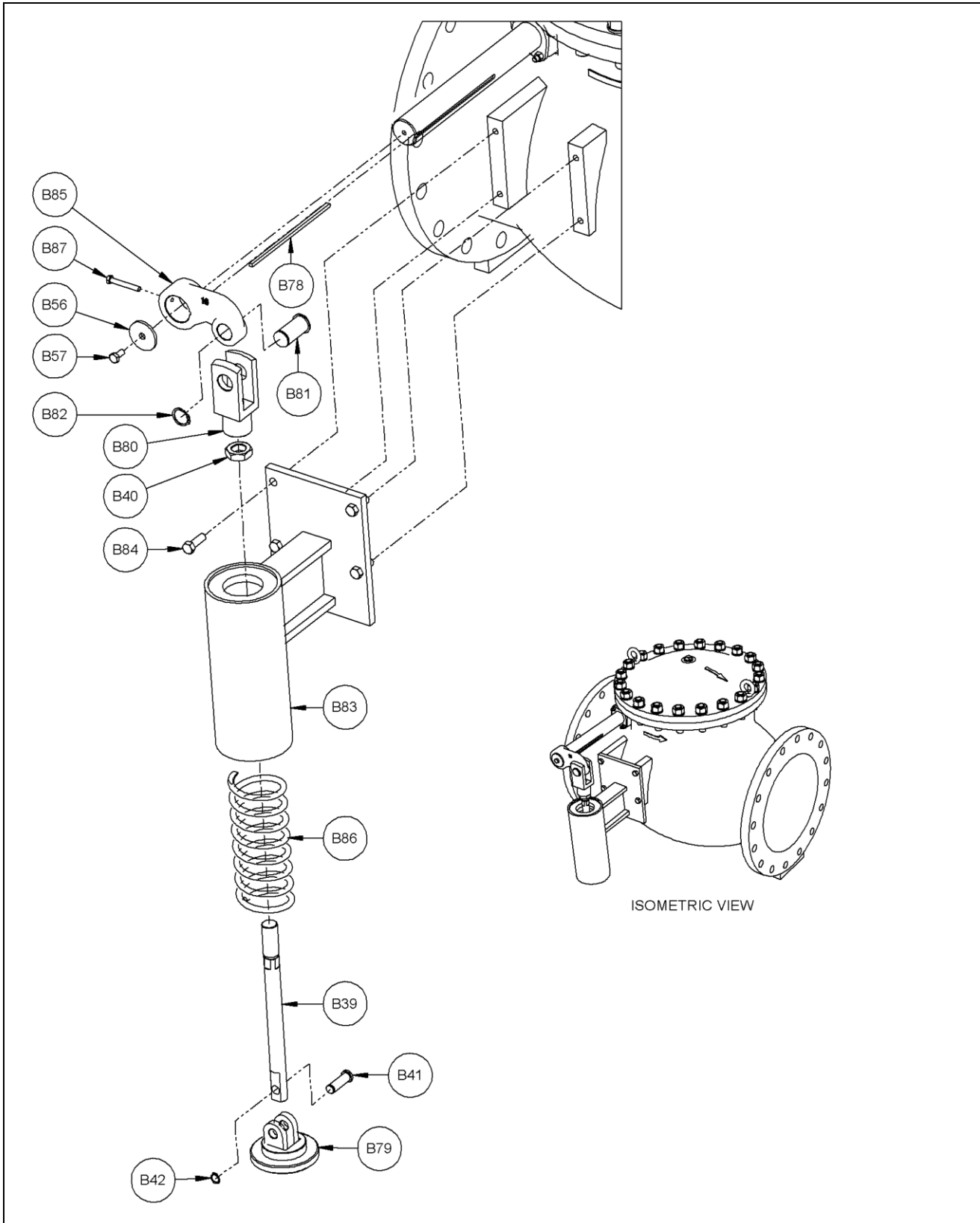

Figure 7 - CVS-EDV Swing Check Valve (Lever & Spring 16-30'')

Table 1 - CVS-EDV Swing Check Valve Parts Lever & Weight, Lever & Spring, and Cylinder Parts

Item Number	Description	Item Number	Description
A1	Body	B31	Spring Lever Arm Ret. Screw 3-14"
A2	Cover	B32	Spring Bracket
A3	Cover Gasket	B33	Lever Arm Fabrication 3-14"
A5	Body Seat Ring	B34	Spring 3-14"
A6	Seat O-Ring	B35	Eye Bolt
A8	Key	B36	Eye Bolt Washer
A9	Disc Arm	B37	Eye Bolt Retaining Nut
A10	Disc	B38	Spring Bracket Screw
A11	Limit Screw	B39	Spring Shaft
A13	Shaft	B40	Spring Shaft Nut
A14	Body Seat Screw	B41	Spring Cylinder Pin
A15	Disc Seat	B42	Spring Cylinder Pin Retaining Ring
A16	Seat Retaining Ring	B54	Counterweight Lever Arm Fabrication
A17	Disc Seat Screw	B55	Lever Weight Assy Set Screw
A18	Disc Stem	B56	Lever Arm Washer
A19	Disc Nut	B57	Lever Arm to Shaft Set Screw
A20	Disc Washer	B58	Lever Arm Set Screw Nut
A21	Filler Ring	B59	Counterweight Arm
A23	V-Type Packing	B60	Counterweight
A25	Gland	B61	Cushion Lever Clevis Pin
A26	Gland Nut	B62	Cushion Lever Clevis Pin Retaining Ring
A27	Gland Stud	B63	Y-Connector
A28	Cover Nut	B65	Counterweight Set Screw
A29	Cover Nut Washer	B66	Cylinder Bracket
A30	Cover Stud	B67	Flow Control Valve
A31	Data Plate	B68	Pneumatic Cylinder
A32	Drive Screws	B69	Cylinder Bracket Mounting Bolt
A42	Plug	B70	Clevis Pin
A64	Cover Eye Bolt	B71	Clevis Pin Retaining Ring
		B72	Female Clevis Bracket
		B73	Bracket Shim
		B74	Male Clevis Bracket
		B75	Eye Bracket Mounting Bolt
		B76	AC Assy Set Screw
		B77	Lever Arm Set Screw
		B78	Long Flat Key
		B79	Spring Tension Plate
		B80	Y-Connection

Table 1 - Continued

Lever & Weight, Lever & Spring, and Cylinder Parts	
Item Number	Description
B81	Y-Connector Pin
B82	Y-Connector Pin Retaining Ring
B83	Spring Cylinder
B84	Spring Cylinder Mount Bolt
B85	Lever arm fabrication 16-30"
B86	Spring 16-30"
B87	Spring Lever Arm Ret. Screw 16-30"
B88	Cushion Lever

Troubleshooting

Condition	Possible Cause	Corrective Action
Shaft seal leaks.	Packing is loose.	Tighten gland nuts only until the leak stops.
	Packing is worn.	Replace Packing.
Valve leaks excessively from one side of the disc to the other.	Foreign matter caught between disc and seat.	Fully open valve to remove object.
	Disc seat is worn or damaged.	Repair disc seat or replace valve.
Valve leaks at flange joint.	Loose flange bolting.	Tighten flange bolting.
	Blown flange gasket.	Replace flange gasket.
	Misalignment or damage to field piping and supports.	Adjust misalignment or repair piping or supports.
	Damaged flange face/s or improper flange connections.	Repair flange, replace valve body or adjust flange connections.
Valve does not fully close.	Object is wedged between seat and disc.	Fully open valve to remove object.
	Packing Gland is too tight	Loosen packing gland fasteners. Packing may need to be replaced if leakage occurs.

Limited Warranty

DeZURIK, Inc. ("Seller") manufactured products, auxiliaries and parts thereof that we manufacture for a period of twenty-four (24) months from date of shipment from Seller's factory, are warranted to the original purchaser only against defective workmanship and material, but only if properly stored, installed, operated, and serviced in accordance with Seller's recommendations and instructions.

For items proven to be defective within the warranty period, your exclusive remedy under this limited warranty is repair or replacement of the defective item, at Seller's option, FCA Incoterms 2020 Seller's facility with removal, transportation, and installation at your cost.

Products or parts manufactured by others but furnished by Seller are not covered by this limited warranty. Seller may provide repair or replacement for other's products or parts only to the extent provided in and honored by the original manufacturer's warranty to Seller, in each case subject to the limitations contained in the original manufacturer's warranty.

No claim for transportation, labor, or special or consequential damages or any other loss, cost or damage is being provided in this limited warranty. You shall be solely responsible for determining suitability for use and in no event shall Seller be liable in this respect.

This limited warranty does not warrant that any Seller product or part is resistant to corrosion, erosion, abrasion or other sources of failure, nor does Seller warrant a minimum length of service.

Your failure to give written notice to us of any alleged defect under this warranty within twenty (20) days of its discovery, or attempts by someone other than Seller or its authorized representatives to remedy the alleged defects therein, or failure to return product or parts for repair or replacement as herein provided, or failure to store, install, or operate said products and parts according to the recommendations and instructions furnished by Seller shall be a waiver by you of all rights under this limited warranty.

This limited warranty is voided by any misuse, modification, abuse or alteration of Seller's product or part, accident, fire, flood or other Act of God, or your failure to pay entire contract price when due.

The foregoing limited warranty shall be null and void if, after shipment from our factory, the item is modified in any way or a component of another manufacturer, such as but not limited to; an actuator is attached to the item by anyone other than a Seller factory authorized service personnel.

All orders accepted shall be deemed accepted subject to this limited warranty, which shall be exclusive of any other or previous warranty, and this shall be the only effective guarantee or warranty binding on Seller, despite anything to the contrary contained in the purchase order or represented by any agent or employee of Seller in writing or otherwise, notwithstanding, including but not limited to implied warranties.

THE FOREGOING REPAIR AND REPLACEMENT LIMITED WARRANTY IS IN LIEU OF ALL OTHER WARRANTIES, OBLIGATIONS AND LIABILITIES, INCLUDING, BUT NOT LIMITED TO, ALL WARRANTIES OF FITNESS FOR A PARTICULAR PURPOSE OR OF MERCHANTABILITY OR OTHERWISE, EXPRESSED OR IMPLIED IN FACT OR BY LAW, AND STATE SELLER'S ENTIRE AND EXCLUSIVE LIABILITY AND YOUR EXCLUSIVE REMEDY FOR ANY CLAIM IN CONNECTION WITH THE SALE AND FURNISHING OF SERVICES, GOODS OR PARTS, THEIR DESIGN, SUITABILITY FOR USE, INSTALLATION OR OPERATIONS. NEITHER ANY PERFORMANCE OR OTHER CONDUCT, NOR ANY ORAL OR WRITTEN INFORMATION, STATEMENT, OR ADVICE PREPARED BY SELLER OR ANY OF OUR EMPLOYEES OR AGENTS WILL CREATE A WARRANTY, OR IN ANY WAY INCREASE THE SCOPE OR DURATION OF THE LIMITED WARRANTY.

Disclaimer

Metric fasteners should not be used with ASME Class 150/300 bolt holes and flange bolt patterns. If you use metric fasteners with ASME Class 150/300 bolt holes and flange bolt patterns, it may lead to product failure, injury, and loss of life. DeZURIK Inc. disclaims all liability associated with the use of metric fasteners with ASME Class 150/300 bolt holes and flange patterns, including but not limited to personal injury, loss of life, loss of product, production time, equipment, property damage, lost profits, consequential damages of any kind and environment damage and/or cleanup. Use of metric fasteners with ASME Class 150/300 bolt holes and flange bolt patterns is a misuse that voids all warranties and contractual assurances. If you use metric fasteners with ASME Class 150/300 bolt holes and flange bolt patterns, you do so at your sole risk and any liability associated with such use shall not be the responsibility of DeZURIK, Inc. In addition to the foregoing, DeZURIK's Manufacturer's Conditions apply.

Limitation of Liability

IN NO EVENT SHALL SELLER BE LIABLE FOR ANY DIRECT, INDIRECT, SPECIAL, PUNITIVE, EXEMPLARY, OR CONSEQUENTIAL DAMAGES (INCLUDING, BUT NOT LIMITED TO; DAMAGE TO OR LOSS OF OTHER PROPERTY OR EQUIPMENT, BUSINESS INTERRUPTION, COST OF SUBSTITUTE PRODUCTS, LOSS OF TIME, LOSS OF PROFITS OR REVENUE, COST OF CAPITAL, LOSS OF USE, OR DIMINUTION IN VALUE) WHATSOEVER, AND SELLER'S LIABILITY, UNDER NO CIRCUMSTANCES, WILL EXCEED THE CONTRACT PRICE FOR THE GOODS AND/OR SERVICES FOR WHICH LIABILITY IS CLAIMED. ANY ACTION FOR BREACH OF CONTRACT BY YOU, OTHER THAN RIGHTS RESPECTING OUR LIMITED WARRANTY DESCRIBED ABOVE, MUST BE COMMENCED WITHIN 12 MONTHS AFTER THE DATE OF SALE.

Sales and Service

For information about our worldwide locations, approvals, certifications and local representative:

Web site: www.dezurik.com E-Mail: info@dezurik.com



250 Riverside Ave. N., Sartell, MN 56377 • Phone: 320-259-2000 • Fax: 320-259-2227

DeZURIK, Inc. reserves the right to incorporate our latest design and material changes without notice or obligation.

Design features, materials of construction and dimensional data, as described in this manual, are provided for your information only and should not be relied upon unless confirmed in writing by DeZURIK, Inc. Certified drawings are available upon request.