

# DeZURIK KGC-BD BIDIRECTIONAL KNIFE GATE VALVE

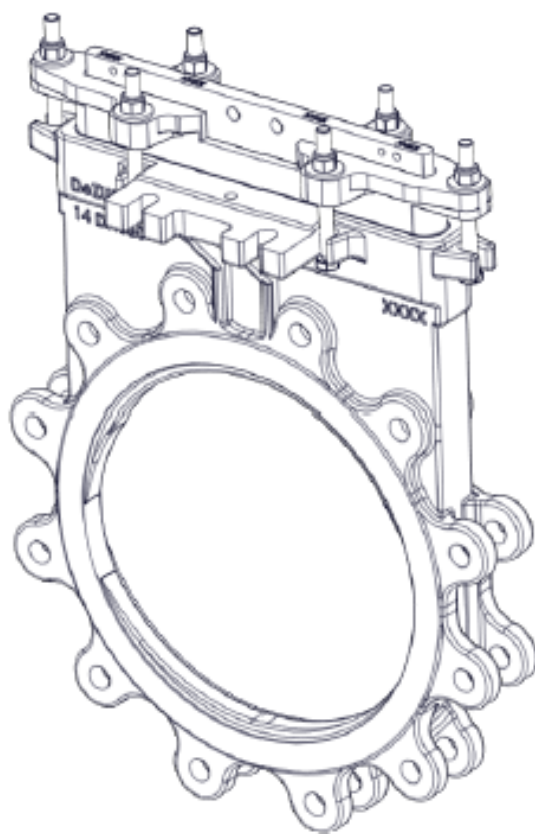

Instruction **D11061**  
October 2019

## Instructions

These instructions are for use by personnel who are responsible for the installation, operation and maintenance of DeZURIK valves, actuators or accessories.

## Safety Messages

All safety messages in the instructions are identified by a general warning sign and the signal word CAUTION, WARNING or DANGER. These messages indicate procedures to avoid injury or death.

Safety label(s) on the product indicate hazards that can cause injury or death. If a safety label becomes difficult to see or read, or if a label has been removed, please contact DeZURIK for replacement label(s).

---

### **⚠WARNING**

**Personnel involved in the installation or maintenance of valves should be constantly alert to potential emission of pipeline material and take appropriate safety precautions. Always wear suitable protection when dealing with hazardous pipeline materials. Handle valves which have been removed from service with suitable protection for any potential pipeline material in the valve.**

---

## Inspection

Your DeZURIK product has been packaged to provide protection during shipment; however, items can be damaged in transport. Carefully inspect the unit for damage upon arrival and file a claim with the carrier if damage is apparent.

## Parts

Replaceable wear parts are listed on the assembly drawing. These parts can be stocked to minimize downtime. Order parts from your local DeZURIK sales representative or directly from DeZURIK. When ordering parts please provide the following information:

**If the valve has a data plate:** please include the 7-digit part number with either 4-digit revision number (example: 9999999R000) or 8-digit serial number (example: S1900001) whichever is applicable. The data plate will be attached to the valve assembly. Also, include the part name, the assembly drawing number, the balloon number and the quantity stated on the assembly drawing.

**If there isn't any data plate visible on the valve:** please include valve model number, part name, and item number from the assembly drawing. You may contact your local DeZURIK Representative to help you identify your valve.

## DeZURIK Service

DeZURIK service personnel are available to maintain and repair all DeZURIK products. DeZURIK also offers customized training programs and consultation services. For more information, contact your local DeZURIK sales representative or visit our website at [DeZURIK.com](http://DeZURIK.com).

## **Table of Contents**

Description	4
Handling	4
Installation	6
Operation	7
Lubrication	7
Packing	7
Adjustment	7
Drawings	8
Packing Replacement	9
<i>Removing the Old Packing</i>	9
<i>Installing the New Packing</i>	10
<i>Reassembling the Valve</i>	10
Replacing the Seat	11
<i>Description</i>	11
<i>Definitions</i>	11
<i>Seat Removal</i>	12
<i>Seat Installation</i>	14
Replacing the Gate	16
Troubleshooting	17

---

### Description

KGC-BD knife gate valves have a stainless steel body, gate and a resilient perimeter seat. The KGC-BD knife gate valve is available in 2-36" (50-900mm) sizes. A choice of several actuators and accessories is available.

### Handling



**WARNING!**

A potential hazard exists with handling valves. Failure to handle valves properly may cause a valve to shift, slip or fall causing serious injury or death and/or equipment damage.

*The points below are for reference purposes only. Use safe and proper lifting and support techniques. DO NOT lift valves with any adjoining pipe or other equipment attached. Lift with properly rated lifting equipment. Follow jurisdictional safety requirements.*

Suggested lifting points are as shown below to lift valve assemblies that are in a horizontal orientation. Eye bolts in flange through holes can be used to lift the valve body or, for 2-12" valves, a sling can be strapped around the top of the valve body.

For valves with bevel gear actuators, a sling or chain can be wrapped around the bevel gear actuator body, between the mounting plate and the input shaft housing. This would be in conjunction with lifting from the valve body as well. See Figure 1.

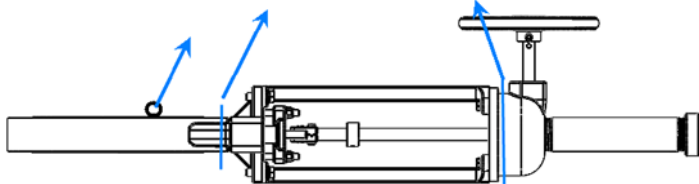

**Figure 1— Knife Gate Valve with Bevel Gear Actuator, Horizontal Lifting**

For valves with pneumatic cylinder actuators, a sling can be wrapped around the cylinder, near the cylinder head (piston rod end). This would be in conjunction with lifting from the valve body. Utilize caution to not bump, dent or damage the cylinder tube. DO NOT utilize the cylinder tie-rod ends to lift. See Figure 2.

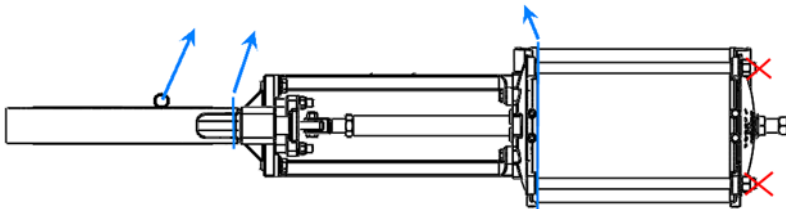

**Figure 2, Knife Gate Valve with Pneumatic Cylinder Actuator, Horizontal Lifting**

### Handling *continued*

For valves with handwheel actuators, a sling or chain can be wrapped through the rim of the handwheel. For chainwheel actuators, a sling can be wrapped in the area between the yoke/legs and the chainwheel/guide assembly. This would be in conjunction with lifting from the valve body as well. See Figure 3.

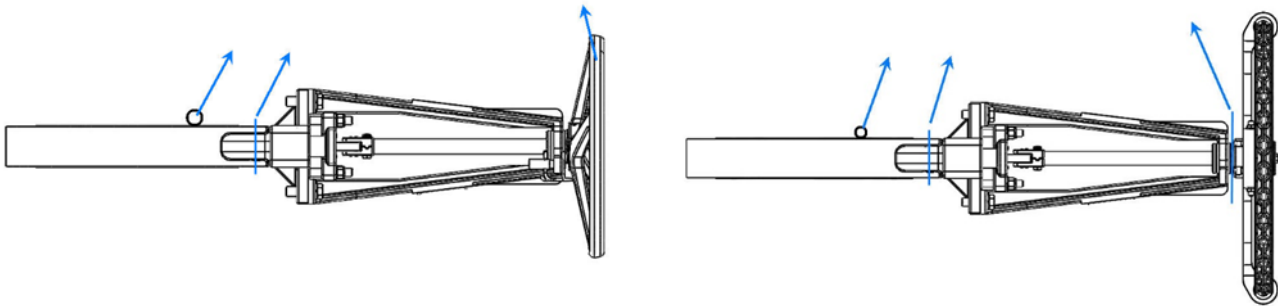
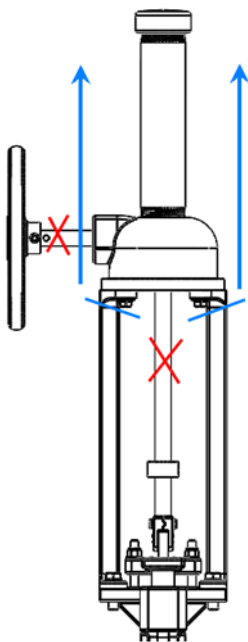

**Figure 3, Knife Gate Valve with Handwheel or Chainwheel Actuator, Horizontal Lifting**

Suggested lifting options are as shown below to lift valve assemblies that are in a vertical orientation. For valves with bevel gear actuators, wrap slings or chains around the top of each leg. Use caution not to put any side load on the bevel gear input shaft or on the valve's threaded stem. See Figure 4.

For valves with pneumatic cylinder actuators, wrap slings around the top of each leg. Use caution to not bump, dent or damage the cylinder tube and avoid any side load on the cylinder piston rod. DO NOT utilize the cylinder tie-rod ends to lift. See Figure 5.

For valves with handwheel or chainwheel actuators, wrap slings or chains around the top of the each leg or yoke side. Use caution to not put any side load on the valve's threaded stem. See Figure 6.



**Figure 4- Knife Gate Valve with Bevel Gear Actuator, Vertical Lifting**

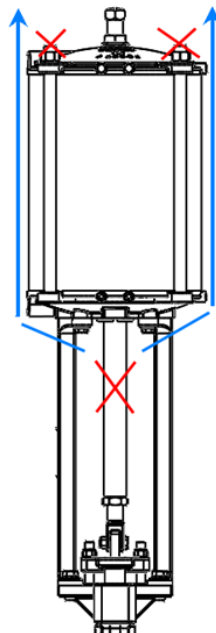

**Figure 5- Knife Gate Valve with Pneumatic Cylinder Actuator, Vertical Lifting**

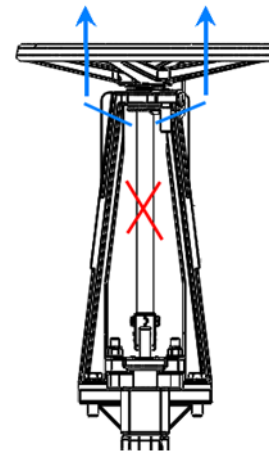

**Figure 6- Knife Gate Valve with Handwheel or Chainwheel Actuator, Vertical Lifting**

### Installation

Install the valve between ASME Class 125 or Class 150 pipeline flanges, or other flanges that match valve end connection. Flange gaskets are required. Before installation, remove foreign material such as weld spatter, oil, grease, and dirt from the valve and pipeline.

#### Normal Installations

The bi-directional KGC-BD knife gate valve can be oriented either way in the pipeline. The perimeter seat in the valve will seal the valve in the closed position in both directions.

The bi-directional KGC-BD knife gate valves are not intended for gravity (dry) service applications.

#### General Guidelines

Observe the following points to prevent distortion of the valve body and gate when the flange bolts are tightened:

- Align the mating pipeline flanges.
- Select the length of the flange bolts so that the bolts used in the blind holes near the chest area of the valve do not bottom out when tightened. We recommend using studs with nuts in the blind holes.
- Tighten the flange bolts evenly, in a crisscross pattern. Refer to Table A for recommended flange bolt/stud torques.

**Note:** Torque ranges are based on ASME Pressure Vessel Code Calculations and lab test data. These torques are only for the listed gasket types. For other gasket types listed in ASME, consult DeZURIK.

After installing the valve, pressurize pipeline and ensure the packing is not leaking. If the packing leaks, adjust the packing as described on the next page.

**Table A: Recommended Flange Bolt/Stud Torque Range in ft-lbs (non-lubricated)**

Valve Size	ASME Gasket Types	
	Rubber with Soft Fabric Filler, & 1/8" Thick Hard	Soft Elastomer Gasket Shore Durometer < 75A
2" (50mm)	26 - 29	8 - 9
3" (80mm)	37 - 41	14 - 16
4" (100mm)	26 - 29	11 - 12
5" (125mm)	36 - 40	17 - 19
6" (150mm)	41 - 45	22 - 24
8" (200mm)	55 - 61	35 - 39
10" (250mm)	56 - 62	40 - 44
12" (300mm)	80 - 88	59 - 65
14" (350mm)	107 - 118	81 - 89
16" (400mm)	103 - 114	79 - 87
18" (450mm)	128 - 141	102 - 112
20" (500mm)	123 - 136	99 - 109
24" (600mm)	188 - 207	155 - 171
30" (750mm)	198 - 218	168 - 185
36" (900mm)	289 - 318	248 - 273

## **Operation**

The gate in the valve is positioned by the valve actuator. The actuator moves the gate over the valve port in the closed position, and withdraws the gate from the port in the open position. Refer to the Actuator Instructions for adjustment and maintenance requirements for the actuator.

## **Lubrication**

The valve does not require lubrication. If applicable, ensure that valve threaded stems are maintained with proper lubrication. Refer to the Actuator Instructions for lubrication requirements for the actuator.

## **Packing**

The gate packing (A2) is contained and compressed by the packing gland (A4). See Figure 1 for component identification.

**Note:** The packing gland (A4) is slightly loosened prior to shipping. This is done to increase the life of the packing during extended storage.

## **Adjustment**

If packing leaks, tighten the adjustment nuts (A7) on top of the packing gland. Tighten the nuts evenly and gently just enough to stop the leak. Over tightening will cause excessive operating forces, and will decrease the life of the packing.

**Drawings**

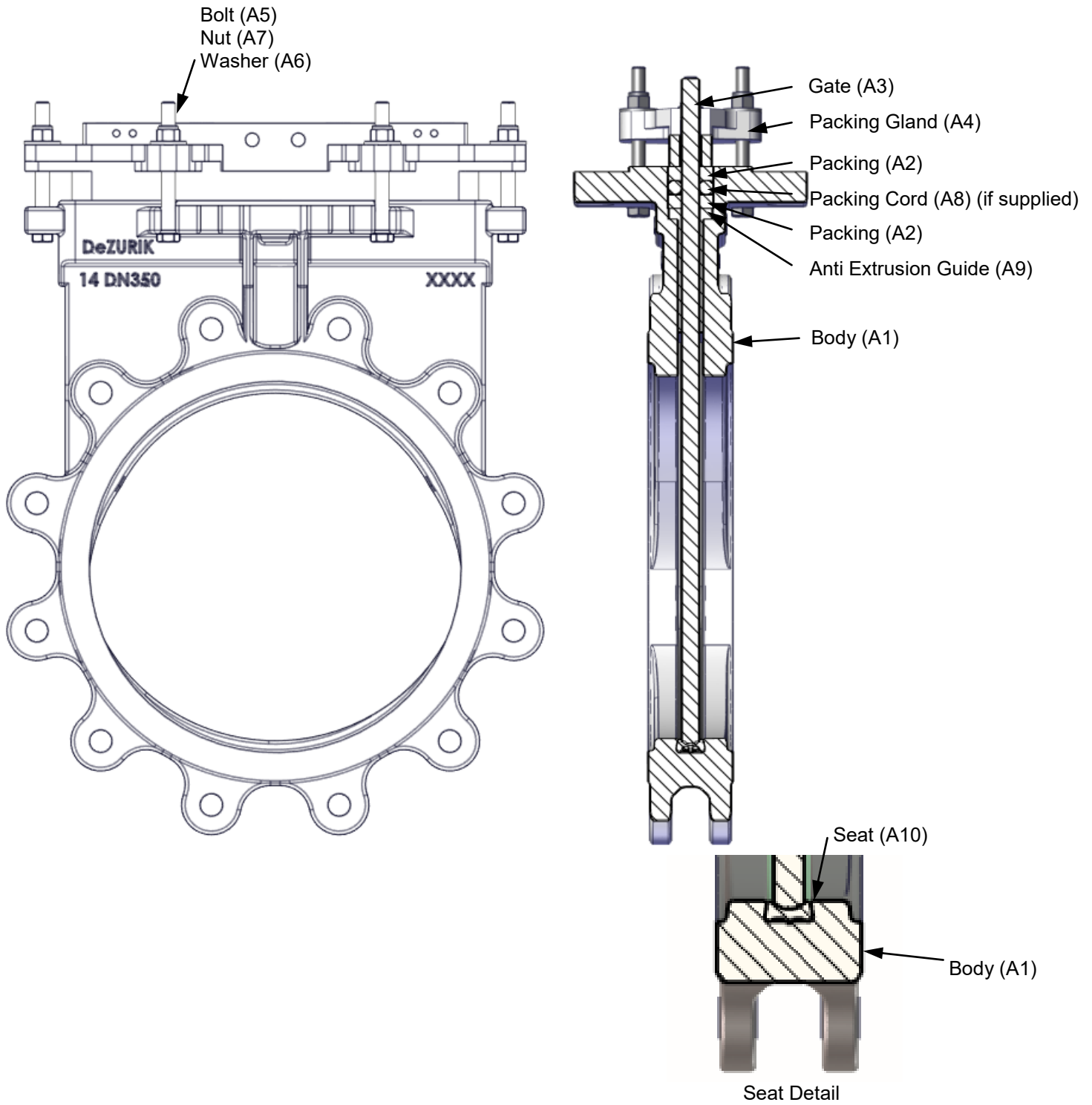

**Figure 1—Component Identification**



## Packing Replacement

### *Removing the Old Packing*



**WARNING!**

Pipeline pressure can cause personal injury or equipment damage. Relieve pipeline pressure before removing gate stem and packing gland nuts.

---

1. Relieve the pressure in the pipeline and close the valve.



**WARNING!**

Accidental operation of power actuator can cause personal injury or equipment damage. Disconnect and lock out power to actuator before servicing.

---

2. If the actuator is powered, disconnect and lock out power to prevent accidental operation of the actuator.
3. Remove the two screws and nuts near the top of the gate and disengage the stem from the gate by stroking the actuator (not the valve) to the open position.
4. Remove the gland nuts (A7), bolts (A5), washer (A6) and packing gland (A4).
5. Remove the used packing (A2) and packing cord (A8), if supplied. Inspect and replace anti-extrusion guides (A9) if damaged.

# DeZURIK

## KGC-BD BI-DIRECTIONAL KNIFE GATE VALVES

### Installing the New Packing

Packing (A2) strip length and quantity are shown in Table B. DeZURIK provides extra packing in the packing kits, but do not try to put more packing into a layer than shown in Table B.

Do not compress the packing any more than needed to stop leaks.

1. Ensure the gate (A3) is well within and centered in the body before packing.
2. Place the anti-extrusion guides (A9) in the bottom of the packing chamber (machined slots).
3. Assemble and pack the rings one at a time, with the ends together, but not overlapped

**Note:** Stagger the joints, on the long side of the packing chamber. Use a square-ended wood or plastic tool, driven by a hammer or mallet, to pack the rings. Do not use a sharp tool to pack the rings.

Ensure the inside and outside edges of each ring are packed against the gate and packing chamber, so that each strip is compressed flat and evenly.

4. For packing systems with packing cord (A8), assemble and pack one row of packing (A2) and then insert the packing cord (A8). Assemble and pack the last row of packing. See detail below:

Valve Size	Square Size	Length, inches	Quantity (A2)	Qty Cord (A8)
2" (50mm)	3/8"	7.50	3 w/o cord	1
3" (80mm)		9.50		
4" (100mm)		11.50		
5" (125mm)		13.50		
6" (150mm)		15.50		
8" (200mm)		20.00		
10" (250mm)	1/2"	25.00	3 w/o cord	1
12" (300mm)		29.00		
14" (350mm)		32.00		
16" (400mm)		36.75		
18" (450mm)	5/8"	41.25	2 with cord	
20" (500mm)		45.25		
24" (600mm)		53.50		
30" (750mm)	3/4"	66.25	2 with cord	
36" (900mm)		79.0		

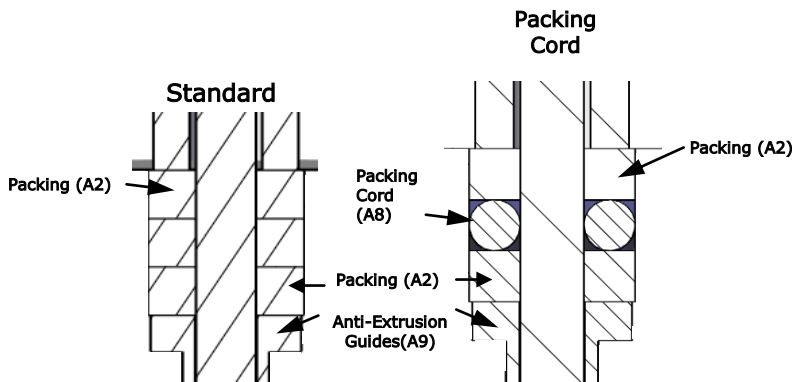

### ***Reassembling Valve***

1. Replace the packing gland (A4), bolts (A5), washer (A6) and nuts (A7). Tighten the nuts evenly and finger tight, plus 1/2 turn.
2. Reconnect the stem to the gate with the two screws and nuts.
3. If the actuator is a powered actuator, reconnect power to the actuator.
4. Pressurize the pipeline and inspect packing for leakage.
5. If packing leaks, tighten the adjustment nuts (A7) on top of the packing gland (A4). Tighten the nuts (A7) evenly and gently - just enough to stop the leak. Over tightening will cause excessive operating forces, and will decrease the life of the packing.

## **Replacing the Seat**

### ***Description***

The perimeter seat in KGC-BD style valves is a U-shaped seat with round pucks at each end which fit into a groove with pocketed ends within the valve body. Replacement of the perimeter seat can be accomplished with access to the top of the valve body, such as if the valve body was still mounted to the mating pipe flanges.

If there are any difficulties encountered while following these instructions, please contact DeZURIK for assistance.

### ***Definitions***

For the purpose of the seat replacement, the following valve features are defined:

- Packing Chamber – this is the area at the top of the valve body which contains the layers of packing that seal between the gate and the body.
- Perimeter Seat Groove – this is the U-shape groove within the valve body in which the perimeter seat will nest into.
- Perimeter Seat Puck Pockets – located at the bottom ends of the body packing chamber, these pockets locate the perimeter seat puck ends.
- Perimeter Seat – the KGC-BD style perimeter seat is a U-shaped rubber seal that fits within the body's perimeter seat groove.
- Perimeter Seat Puck Ends – these are the ends of the U-shape KGC-BD style perimeter seat which are to be located within the pockets under the packing chamber of the body.
- Anti-Extrusion Guides – these are at the bottom of the packing chamber, between the perimeter seat puck ends, one on each side of the gate, and also located in appropriate pockets within the body.

## Replacing the Seat *continued*

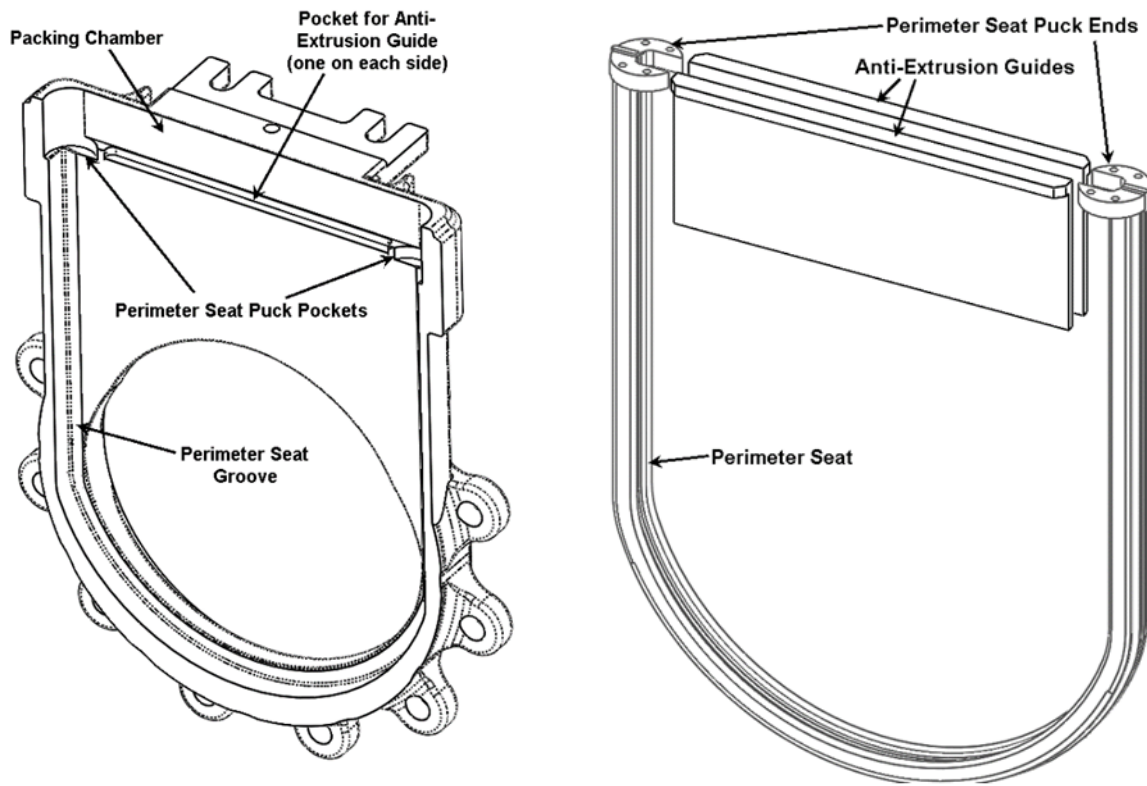

### Seat Removal



**WARNING!**

Pipeline pressure can cause personal injury or equipment damage. Relieve pipeline pressure before removing gate stem and packing gland nuts.

For removal of the actuator top works, gland and old packing.

1. Relieve the pressure in the pipeline and close the valve.
2. If the actuator is powered, disconnect and lock out power to prevent accidental operation of the actuator.
3. Remove the two screws and nuts near the top of the gate and disengage the stem from the gate by stroking the actuator (not the valve) to the open position.
4. Remove the gland nuts (A7), bolts (A5), washers (A6) and packing gland (A4).
5. Remove the used packing (A2) and packing cord (A8), if supplied. Inspect and replace anti-extrusion guides (A9) if damaged.

With the packing removed, the following steps illustrate recommended techniques for the removal of the valve's anti-extrusion guide and perimeter seat.

## Replacing the Seat *continued*

After the gate has been removed, use a bearing pick or similar tool to carefully remove the guides, with attention to preventing the guides from falling into the port area.

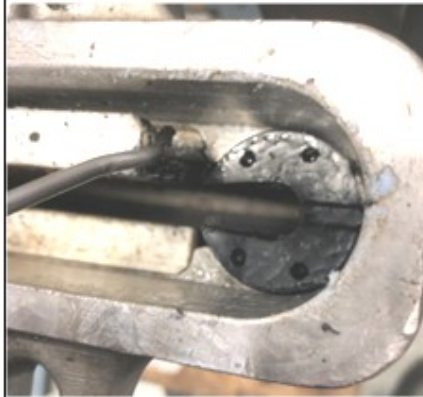

Once the guides have been removed, use a flat end screwdriver to pry the puck ends of the perimeter seat inward. This allows a better grasp of the puck for the next step.

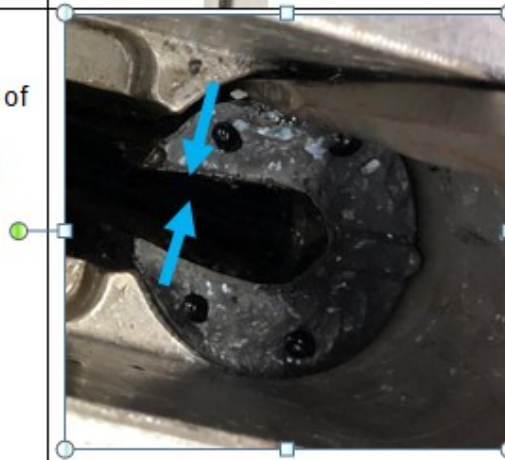

Using channel lock pliers, grasp as much of the puck as possible. With the use of a screwdriver, pry bar or other appropriate tool for leverage, pry up the pliers and puck gradually. Concurrently, observe that the plier jaws maintain a firm grip of the puck. Repeat this on the other side.

Once the pucks are high enough to grasp – pull the seat straight up to remove.



## Replacing the Seat *continued*

### ***Seat Installation***

Prior to installation of new perimeter seat and anti-extrusion guides, check the gate for any significant wear which could be detrimental to the function of the seat and packing.

The seat is the U-shape similar to the port or the gate. Prior to installation, inspect the condition of the new seat, ensuring the rubber has no tears and that the shape does not have any kinks.



Apply a liberal amount of lubricant to the outer surfaces of the seat. A silicone based lubricant is recommended, such as Dow Corning Molykote 111 or 44.

Slide the seat into the top of packing area, pushing down evenly on both pucks as far as possible by hand. Excessive force should be avoided.



### Replacing the Seat *continued*

If the perimeter seat is still evenly protruding well out of the body, grasp directly below the puck with one hand and use a soft faced mallet to tap the seat down into the body – do this evenly a few inches at a time to both sides.

It is important to grasp the perimeter seat under the puck to keep the seat free from buckling.



Once the seat puck ends are close to or within the top of the valve body, use a piece of flat or round bar to finish seating the puck. Alternate back and forth until the puck is seated.

As the pucks get close to their pockets, be sure to hold the pucks back as they go down so that they align with the pockets.

It is allowable for the puck to be sitting slightly proud of the top surface of the pocket.

At this point, check that at the bottom of the body port, the seat is still within its groove. If it is slightly raised at the bottom of the port, the installation of the gate should finish locating the perimeter seat within the groove.

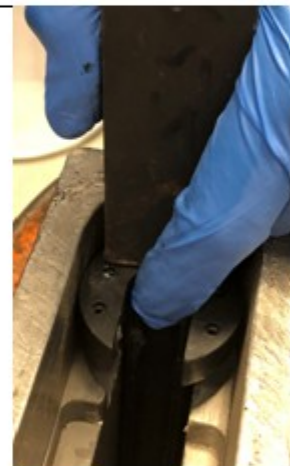

### Replacing the Seat *continued*

Apply a small amount of the lubricant to the inner profile of the seat as shown (both sides). A silicone based lubricant is recommended, such as Dow Corning Molykote 111 or 44.



Apply a small amount of lubricant to the back and front of the anti-extrusion guides and install them carefully. The grease on the back side will allow it to stick to the inner chest wall of the body.



Before proceeding further with valve assembly, clean the gate and remove any burrs that may have formed from usage. Install new packing and reassemble valve as per the *Installing the New Packing and Reassembling Valve* sections.

### Replacing the Gate

See Figure 1 for component identification.



#### **WARNING!**

**Pipeline pressure can cause personal injury or equipment damage. Relieve pipeline pressure before removing gate stem and packing gland nuts.**

1. Relieve the pressure in the pipeline and close the valve.



#### **WARNING!**

**Accidental operation of power actuator can cause personal injury or equipment damage. Disconnect and lock out power to actuator before servicing.**

2. If the actuator is powered, disconnect and lock out power to prevent accidental operation of the actuator.
3. Remove the pipeline flange bolts, and remove the valve from the pipeline.
4. Remove the actuator, actuator yoke, packing gland (A4), and packing (A2) from the valve. Remove and inspect anti-extrusion guides (A9). Replace if damaged.



## Replacing the Gate *continued*

5. Remove and inspect the gate (A3). If the gate appears to be scratched or galled due to too-long flange bolts in the chest area of the body, check for body damage in the tapped flange holes and within the chest cavity. Carefully check the body for damage. Repair or replace the body, as appropriate.
6. Inspect the seat components.
7. If seat replacement is required refer to section Replacing the Seat.
8. Place the new gate (A3) in the body, in the fully closed position.
9. Replace or reinstall the packing (A2) as described in “Installing the New Packing”.
10. Replace the yoke and actuator on the valve.

**Note:** Tighten the nuts evenly and slowly, just enough to stop the leakage. Over tightening will cause excessive operating forces, and will decrease the life of the packing.

## Troubleshooting

Condition	Possible Causes	Corrective Action
Packing leaks, with no evidence of galling on gate	Packing is loose	Adjust packing gland
	Packing is worn or torn	Replace packing
Packing leaks and gate is galled	Packing is worn or torn	Replace packing and gate, check seat for damage or wear
Valve leaks when fully closed, with no evidence of galling on gate	Seat is worn or torn	Replace Seat
Valve leaks when fully closed	Seat is worn or torn	Replace Seat, check gate condition

## Limited Warranty

DeZURIK, Inc. ("Seller") manufactured products, auxiliaries and parts thereof that we manufacture for a period of twenty-four (24) months from date of shipment from Seller's factory, are warranted to the original purchaser only against defective workmanship and material, but only if properly stored, installed, operated, and serviced in accordance with Seller's recommendations and instructions.

For items proven to be defective within the warranty period, your exclusive remedy under this limited warranty is repair or replacement of the defective item, at Seller's option, FCA Incoterms 2020 Seller's facility with removal, transportation, and installation at your cost.

Products or parts manufactured by others but furnished by Seller are not covered by this limited warranty. Seller may provide repair or replacement for other's products or parts only to the extent provided in and honored by the original manufacturer's warranty to Seller, in each case subject to the limitations contained in the original manufacturer's warranty.

No claim for transportation, labor, or special or consequential damages or any other loss, cost or damage is being provided in this limited warranty. You shall be solely responsible for determining suitability for use and in no event shall Seller be liable in this respect.

This limited warranty does not warrant that any Seller product or part is resistant to corrosion, erosion, abrasion or other sources of failure, nor does Seller warrant a minimum length of service.

Your failure to give written notice to us of any alleged defect under this warranty within twenty (20) days of its discovery, or attempts by someone other than Seller or its authorized representatives to remedy the alleged defects therein, or failure to return product or parts for repair or replacement as herein provided, or failure to store, install, or operate said products and parts according to the recommendations and instructions furnished by Seller shall be a waiver by you of all rights under this limited warranty.

This limited warranty is voided by any misuse, modification, abuse or alteration of Seller's product or part, accident, fire, flood or other Act of God, or your failure to pay entire contract price when due.

The foregoing limited warranty shall be null and void if, after shipment from our factory, the item is modified in any way or a component of another manufacturer, such as but not limited to; an actuator is attached to the item by anyone other than a Seller factory authorized service personnel.

All orders accepted shall be deemed accepted subject to this limited warranty, which shall be exclusive of any other or previous warranty, and this shall be the only effective guarantee or warranty binding on Seller, despite anything to the contrary contained in the purchase order or represented by any agent or employee of Seller in writing or otherwise, notwithstanding, including but not limited to implied warranties.

THE FOREGOING REPAIR AND REPLACEMENT LIMITED WARRANTY IS IN LIEU OF ALL OTHER WARRANTIES, OBLIGATIONS AND LIABILITIES, INCLUDING, BUT NOT LIMITED TO, ALL WARRANTIES OF FITNESS FOR A PARTICULAR PURPOSE OR OF MERCHANTABILITY OR OTHERWISE, EXPRESSED OR IMPLIED IN FACT OR BY LAW, AND STATE SELLER'S ENTIRE AND EXCLUSIVE LIABILITY AND YOUR EXCLUSIVE REMEDY FOR ANY CLAIM IN CONNECTION WITH THE SALE AND FURNISHING OF SERVICES, GOODS OR PARTS, THEIR DESIGN, SUITABILITY FOR USE, INSTALLATION OR OPERATIONS. NEITHER ANY PERFORMANCE OR OTHER CONDUCT, NOR ANY ORAL OR WRITTEN INFORMATION, STATEMENT, OR ADVICE PREPARED BY SELLER OR ANY OF OUR EMPLOYEES OR AGENTS WILL CREATE A WARRANTY, OR IN ANY WAY INCREASE THE SCOPE OR DURATION OF THE LIMITED WARRANTY.

## Disclaimer

Metric fasteners should not be used with ASME Class 150/300 bolt holes and flange bolt patterns. If you use metric fasteners with ASME Class 150/300 bolt holes and flange bolt patterns, it may lead to product failure, injury, and loss of life. DeZURIK Inc. disclaims all liability associated with the use of metric fasteners with ASME Class 150/300 bolt holes and flange patterns, including but not limited to personal injury, loss of life, loss of product, production time, equipment, property damage, lost profits, consequential damages of any kind and environment damage and/or cleanup. Use of metric fasteners with ASME Class 150/300 bolt holes and flange bolt patterns is a misuse that voids all warranties and contractual assurances. If you use metric fasteners with ASME Class 150/300 bolt holes and flange bolt patterns, you do so at your sole risk and any liability associated with such use shall not be the responsibility of DeZURIK, Inc. In addition to the foregoing, DeZURIK's Manufacturer's Conditions apply.

## Limitation of Liability

IN NO EVENT SHALL SELLER BE LIABLE FOR ANY DIRECT, INDIRECT, SPECIAL, PUNITIVE, EXEMPLARY, OR CONSEQUENTIAL DAMAGES (INCLUDING, BUT NOT LIMITED TO; DAMAGE TO OR LOSS OF OTHER PROPERTY OR EQUIPMENT, BUSINESS INTERRUPTION, COST OF SUBSTITUTE PRODUCTS, LOSS OF TIME, LOSS OF PROFITS OR REVENUE, COST OF CAPTIAL, LOSS OF USE, OR DIMINUTION IN VALUE) WHATSOEVER, AND SELLER'S LIABILITY, UNDER NO CIRCUMSTANCES, WILL EXCEED THE CONTRACT PRICE FOR THE GOODS AND/OR SERVICES FOR WHICH LIABILITY IS CLAIMED. ANY ACTION FOR BREACH OF CONTRACT BY YOU, OTHER THAN RIGHTS RESPECTING OUR LIMITED WARRANTY DESCRIBED ABOVE, MUST BE COMMENCED WITHIN 12 MONTHS AFTER THE DATE OF SALE.

## Sales and Service

For information about our worldwide locations, approvals, certifications and local representative:

Web site: [www.dezurik.com](http://www.dezurik.com) E-Mail: [info@dezurik.com](mailto:info@dezurik.com)



250 Riverside Ave. N., Sartell, MN 56377 • Phone: 320-259-2000 • Fax: 320-259-2227

*DeZURIK, Inc. reserves the right to incorporate our latest design and material changes without notice or obligation.*

*Design features, materials of construction and dimensional data, as described in this manual, are provided for your information only and should not be relied upon unless confirmed in writing by DeZURIK, Inc. Certified drawings are available upon request.*