

DeZURIK 2-24" (50-600MM) KSL-LA LONG BODY SLURRY KNIFE GATE VALVES

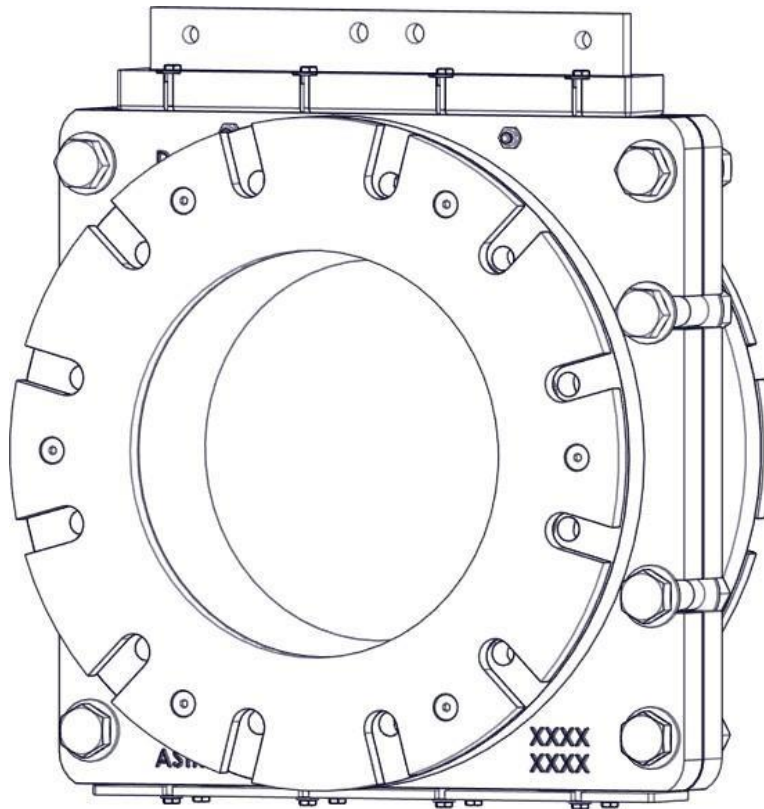

Instructions **D11039**
December 2021

Instructions

These instructions are for use by personnel who are responsible for the installation, operation and maintenance of DeZURIK valves, actuators or accessories.

Safety Messages

All safety messages in the instructions are identified by a general warning sign and the signal word CAUTION, WARNING or DANGER. These messages indicate procedures to avoid injury or death.

Safety label(s) on the product indicate hazards that can cause injury or death. If a safety label becomes difficult to see or read, or if a label has been removed, please contact DeZURIK for replacement label(s).

⚠WARNING

Personnel involved in the installation or maintenance of valves should be constantly alert to potential emission of pipeline material and take appropriate safety precautions. Always wear suitable protection when dealing with hazardous pipeline materials. Handle valves which have been removed from service with suitable protection for any potential pipeline material in the valve.

Inspection

Your DeZURIK product has been packaged to provide protection during shipment; however, items can be damaged in transport. Carefully inspect the unit for damage upon arrival and file a claim with the carrier if damage is apparent.

Parts

Replaceable wear parts are listed on the assembly drawing. These parts can be stocked to minimize downtime. Order parts from your local DeZURIK sales representative or directly from DeZURIK. When ordering parts please provide the following information:

If the valve has a data plate: please include the 7-digit part number with either 4-digit revision number (example: 9999999R000) or 8-digit serial number (example: S1900001) whichever is applicable. The data plate will be attached to the valve assembly. Also, include the part name, the assembly drawing number, the balloon number and the quantity stated on the assembly drawing.

If there isn't any data plate visible on the valve: please include valve model number, part name, and item number from the assembly drawing. You may contact your local DeZURIK Representative to help you identify your valve.

DeZURIK Service

DeZURIK service personnel are available to maintain and repair all DeZURIK products. DeZURIK also offers customized training programs and consultation services. For more information, contact your local DeZURIK sales representative or visit our website at DeZURIK.com.

Table of Contents

Installation	4
<i>Normal Installation</i>	4
<i>Gravity (Dry) Service Installation</i>	5
Operation	5
<i>Outdoor/Cold Service (below freezing)</i>	5
Lubrication (for Non-Dry Service Installations)	6
Adjustment	6
Drawings	7
Top Seal Replacement	8
<i>Removing the Top Seal</i>	8
<i>Installing the New Top Seal</i>	9
Sleeve Replacement	9
<i>Removing the Sleeves</i>	9
<i>Installing the New Sleeves</i>	10
Storage and Shipping	10
Troubleshooting	11

Description

KSL-LA knife gate valves have ductile iron bodies, stainless steel gates, resilient top seals and resilient matching sleeve sets. The KSL-LA is available in 2—24" (50-600mm) sizes, with a choice of several actuators and accessories.

Installation

Install the valve between ASME Class 125 or Class 150 pipeline flanges or other flanges that match the valve end connection. The included, optional on 2-8" valves, resilient sleeve retainers seal against pipe flanges, and thus no flange gaskets are required. Before installation, remove foreign material such as weld spatter, oil, grease, and dirt from the valve and pipeline.



WARNING

Personnel involved in the installation or maintenance of valves should be constantly alert to potential emission of process material and take appropriate safety precautions. Always wear suitable protection when dealing with hazardous process materials. Handle valves which have been removed from service with the assumption of process material within the valve.

Observe the following points to prevent distortion of the valve body and gate when the flange fasteners are tightened.

1. Align the mating pipe flanges.
2. If using bolts, select the bolt length so that they do not extend through the flange so far as to interfere with the valve body.
3. Tighten the fasteners evenly, in a crisscross pattern. Refer to Table 1 for recommended flange torque ranges.

Normal Installation

The valve is bi-directional, it can be installed in either direction. After installation, pressurize the pipeline and ensure the valve does not leak in the full open and full closed positions. The valve is fitted with a self-adjusting top seal and therefore, no tightening is required.

It is the responsibility of the user to determine the final torque values and the bolt, flange, and gasket selections, as applicable, to ensure they are stressed within acceptable limits

Table 1: Recommended Flange Bolt/Stud Torque Ranges

Valve Size	Torque Range (ft-lbs)
2" (50 mm)	8 – 9
3" (80 mm)	14 – 16
4" (100 mm)	11 – 12
5" (125mm)	16 – 18
6" (150 mm)	22 – 24
8" (200 mm)	35 – 39
10" (250 mm)	40 – 44
12" (300 mm)	59 – 65
14" (350 mm)	81 – 89
16" (400 mm)	79 – 87
18" (450 mm)	102 – 112
20" (500 mm)	99 – 109
24" (600 mm)	155 – 171



WARNING

The suggested guidance for installation and bolt tensioning is advisory only, its use by anyone is voluntary and users assume all risks. Care should be taken as any fastener torque is only an indirect indication of tension and is affected by several variables outside of DeZURIK's control. Under/over tightening of fasteners can result in personal injury or costly equipment failure such as, but not limited to flange leakage/damage, bolt failure, gasket under/over compression, chest distortion/seat leakage, gate galling, inability to stroke the gate as designed and other permanent gate and seat damage.

Installation continued



CAUTION

The KSL-LA knife gate valve is designed to discharge media to atmosphere when stroking to prevent solid build-up that may cause leakage. If installing over walkways, electrical equipment or other equipment, ensure that proper precautions (such as the installation and plumbing of the optional drain plate) are taken.



WARNING

Do not plug all ports on the drain plate. This can cause top seal failure.

Gravity (Dry) Service Installation

As the valve is bi-directional, it can be installed in either direction in a vertical pipeline.

Before installation, ensure that the sleeves and gate are free from any grease or liquid type lubricants that might contaminate the media. If applicable, ensure that valve threaded stems are maintained with proper lubrication. Refer to the Actuator Instructions for lubrication requirements for the actuator.

Operation

The valve gate (A2) is positioned by the valve actuator. The actuator strokes the gate through the sleeves to the closed position, flushing the valve in the process. In the closed position, the sleeves press up against the gate, preventing flow and providing a drip-tight seal. In the open position, the sleeves press against each other to seal to provide a drip-tight seal and allow the process media to flow with minimal disturbance. The top seal is designed to prevent leakage from the top of the valve body during stroking.

Even in dry service, ensure that any valve threaded stems are maintained with proper lubrication. Refer to the Actuator Instructions document for adjustment and maintenance requirements for the actuator.

Outdoor/Cold Service (below freezing)

For applications where the valve will be closed for an extended period of time in freezing conditions, we recommend heat tracing or blankets to ensure proper sleeve operation when the valve is opened.

Table 2: Approved Lubricants

<i>Silicone-Based Lubricant</i>	<i>Manufacturer</i>
<i>Recommended:</i>	
MOLYKOTE 111	Dow Corning
<i>Approved Alternatives:</i>	
MOLYKOTE 44	Dow Corning
Sil Glyde	AGS Company
Chemplex 825	FUCHS
7 Release Compound	Dow Corning
G661	Novagard

Lubrication (for Non-Dry Service Installations)

Lubrication is provided to the top seal and sleeves by four 1/8" grease fittings in the body of the valve. See Table 2 for a list of approved silicone based lubricants. See Table 3 for recommended lubrication intervals. If applicable, ensure that valve threaded stems are maintained with proper lubrication.

The top seal and sleeves should be lubricated during inspection. Apply a thin coat of lubricant to the top seal and sleeves before installation. See the *Top Seal Replacement* and *Sleeve Replacement* sections of this manual for instructions.

In between inspections, lubricate the valve using the grease fittings on the body. If applicable, ensure that valve threaded stems are maintained with proper lubrication. Refer to the Actuator Instructions for lubrication requirements for the actuator.

Wipe the gate clean at regular intervals to prolong the life of the top seal and sleeves.

Adjustment

The valve is fitted with a self-adjusting top seal and therefore, no tightening is required.

Table 3: Recommended Lubrication Intervals

<i>Valve Size</i>	<i>Number of Strokes</i>	<i>Quantity Grease/ per Fitting</i>
2–10" (50—250 mm)	100	100g
12–24" (300—600 mm)	50	160g

Drawings

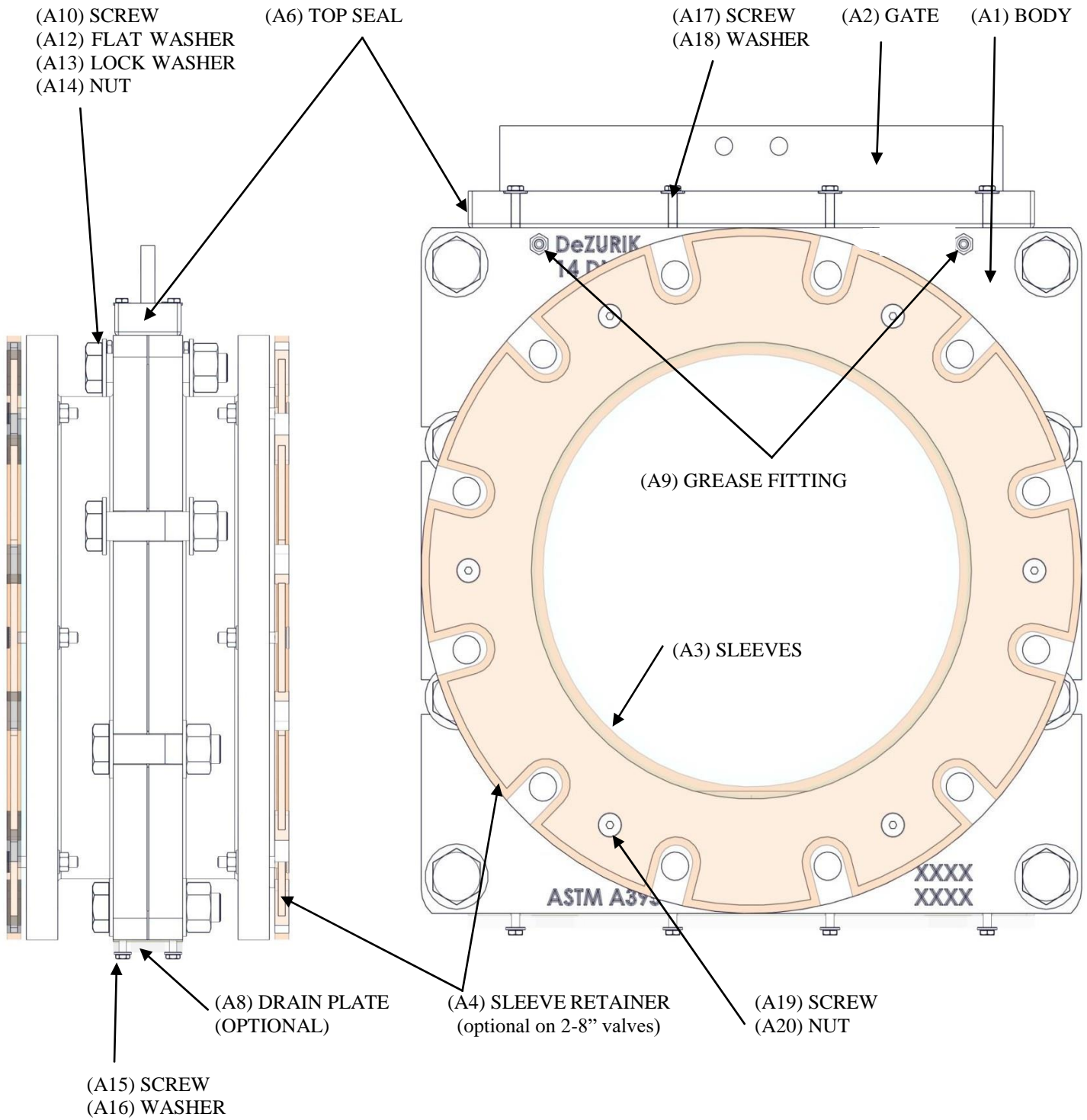

Figure 1—Component Identification

Top Seal Replacement

The resilient molded top seal with encapsulated plate is designed to apply even sealing force to the top of the valve. The seal must be replaced if it has been damaged or if it still leaks after it is fully tightened.

Removing the Top Seal

**WARNING!**

Pipeline pressure can cause personal injury or equipment damage. Relieve pipe- line pressure before servicing.

1. Ensure the gate (A2) is fully open.

**WARNING!**

Accidental operation of power actuator can cause personal injury or equipment damage. Disconnect and lock out power to actuator before servicing.

2. If the actuator is powered, disconnect the power source or ensure that it is properly locked out.
3. Remove the fasteners connecting the actuator clip to the gate.
4. For 2—8” valves, loosen the fasteners (A10, 12, 13, 14) on one side of the actuator frame mounting and completely remove them from the other side of the frame. Rotate the actuator and frame assembly until it is clear of the gate.
5. For 10—24” valves, ensure the actuator frame is supported and remove all frame mounting fasteners (A10, 12, 13, 14). Lift off the actuator and frame assembly and set it aside.
6. On the gate, mark the position of the gate (A2) relative to the top surface of the top seal (A6). Otherwise, measure the position of the top surface of the gate to the top surface of the valve body (A1) in the open position. This will allow for easier installation of the gate after the seal has been replaced.
7. Loosen the top seal retaining fasteners (A17, 18).
8. Pull the gate (A2) straight out until it clears the top seal (A6). Some force may be necessary.
9. Remove the seal retaining fasteners (A17, 18) and place aside for reuse. The top seal (A6) is now free to remove.

Installing the New Top Seal

1. Apply a liberal amount of approved lubricant (see Table 2: Approved Lubricants) to the inside ribbed surfaces of the top seal (A6). For dry service application, no lubricant can be used.
2. Place the top seal (A6) so that the bottom surface (rounded edges) is in contact with the top of the valve body (A1) and the TOP marking is visible when assembled. For dry service application, a top seal is not required.
3. Hand-tighten all fasteners (A17, 18) to ensure that the seal is aligned properly. Evenly tighten only the fasteners at the corners of the seal. Do not over-tighten.
4. Apply silicone lubricant to the leading edge faces of the gate (A2). For dry service application, no lubricant can be used.
5. Place the gate (A2) into the top seal (A6) and push it down until it reaches the mark made in *Top Seal Removal* step 7. If a mark was not made, push it down until it just contacts the top of the sleeves.
6. Evenly tighten the remaining top seal fasteners (A17, 18) (10” and larger valves only). Do not over tighten.
7. Replace the actuator and frame assembly and tighten all fasteners (A10, 12, 13, 14).
8. Reattach the actuator clip and tighten the fasteners.

Sleeve Replacement

The sleeves provide a drip-tight seal when the valve is closed. If either sleeve is to be replaced, the valve must be removed from service.

Removing the Sleeves

**WARNING!**

Pipeline pressure can cause personal injury or equipment damage. Relieve pipeline pressure before removing gate stem and top seal.

1. Relieve the pressure in the pipeline.
-

**WARNING!**

Accidental operation of power actuator can cause personal injury or equipment damage. Disconnect and lock out power to actuator before servicing.

2. Ensure the gate (A2) is fully open.
3. If the actuator is powered, ensure the actuator is properly locked out.
4. Remove the valve from the pipeline.
5. Remove the sleeve retainer fasteners (A19, 20) and the sleeve retainers (A4) (if equipped).
6. Pull the sleeves (A3) out of the body (A1).
Inspect the sleeves (A3) for damage or excessive wear. If either is present, replace the sleeves.

Installing the New Sleeves

1. Apply approved lubricant to the surfaces of each sleeve (A3) that will contact each other after they are installed into the body. Also apply a thin coating of the same lubricant to the outside diameters that will contact the valve body (A1) bores. For dry service application, no lubricant can be used.
2. With the gate in the open position (fully retracted), place the sleeves (A3) into the valve body bore and press into place from each side. It is recommended the valve be placed in a stand so that the two sleeves are equally inserted into the body (A1).
3. Align the sleeve retainer (A4) (if supplied) mounting holes with the matching mounting holes on each flange.
4. Install all retainer fasteners (A19, 20) (if supplied) so that the screws only engage a few threads into the nuts (both sides of the valve).
5. Evenly tighten the fasteners (A19, 20) (if supplied) until the screws just break through the nylon locking material of the nuts.
6. Reinstall the valve into the pipeline following the specifications of the *Installation* section.
7. If the actuator is powered, remove lock out or reconnect the power, reversing the measures taken in *Sleeve Removal* step 3.

Storage and Shipping

KSL-LA valves supplied with actuators are shipped in the open position. This is also the recommended position for installation and storage.

KSL-LA valves supplied without actuators are shipped in the close position with retainer flange fasteners loosen. This is also the recommended position for storage. Evenly tighten the fasteners (A19 & A20) as Installing the New Sleeves step 5 prior to installation.

- The valve should be stored away from direct sunlight, excessive heat, and extreme weather conditions to prevent premature deterioration of the resilient components.
- If possible, store the valve in the vertical position. Manually actuated valves may be stored horizontally if necessary.
- Always inspect the valve after being removed from storage for damage to the flanged surfaces, sealing sleeves, gate, sleeve retainer (if equipped), top seal, or actuator. Inspect the valve on a regular basis while in storage to ensure the valve components have not deteriorated.

Troubleshooting

<i>Condition</i>	<i>Possible Causes</i>	<i>Corrective Action</i>
Top seal leaks during gate closing or opening	Top seal is worn or torn	Replace top seal
	Gate is galled	Replace gate and top seal, check sleeves for damage
Valve continues to discharge media when gate is fully closed	Gate inserted, closed position is not correct	Check actuator for correct function Set stop for inserted gate dimension as per installation drawing
	Sleeves are worn or torn	Replace sleeves
	Gate is galled	Replace gate and sleeves, check top seal for damage
Valve continues to discharge media when gate is fully open	Gate retracted, open position is not correct	Check actuator for correct function Set stop for retracted gate dimension as per installation drawing
	Sleeves are worn or torn	Replace sleeves
Valve allows media flow when gate is fully closed	Gate inserted, closed position is not correct	Check actuator for correct function
		Set stop for inserted gate dimension as per installation drawing

Limited Warranty

DeZURIK, Inc. ("Seller") manufactured products, auxiliaries and parts thereof that we manufacture for a period of twenty-four (24) months from date of shipment from Seller's factory, are warranted to the original purchaser only against defective workmanship and material, but only if properly stored, installed, operated, and serviced in accordance with Seller's recommendations and instructions.

For items proven to be defective within the warranty period, your exclusive remedy under this limited warranty is repair or replacement of the defective item, at Seller's option, FCA Incoterms 2020 Seller's facility with removal, transportation, and installation at your cost.

Products or parts manufactured by others but furnished by Seller are not covered by this limited warranty. Seller may provide repair or replacement for other's products or parts only to the extent provided in and honored by the original manufacturer's warranty to Seller, in each case subject to the limitations contained in the original manufacturer's warranty.

No claim for transportation, labor, or special or consequential damages or any other loss, cost or damage is being provided in this limited warranty. You shall be solely responsible for determining suitability for use and in no event shall Seller be liable in this respect.

This limited warranty does not warrant that any Seller product or part is resistant to corrosion, erosion, abrasion or other sources of failure, nor does Seller warrant a minimum length of service.

Your failure to give written notice to us of any alleged defect under this warranty within twenty (20) days of its discovery, or attempts by someone other than Seller or its authorized representatives to remedy the alleged defects therein, or failure to return product or parts for repair or replacement as herein provided, or failure to store, install, or operate said products and parts according to the recommendations and instructions furnished by Seller shall be a waiver by you of all rights under this limited warranty.

This limited warranty is voided by any misuse, modification, abuse or alteration of Seller's product or part, accident, fire, flood or other Act of God, or your failure to pay entire contract price when due.

The foregoing limited warranty shall be null and void if, after shipment from our factory, the item is modified in any way or a component of another manufacturer, such as but not limited to; an actuator is attached to the item by anyone other than a Seller factory authorized service personnel.

All orders accepted shall be deemed accepted subject to this limited warranty, which shall be exclusive of any other or previous warranty, and this shall be the only effective guarantee or warranty binding on Seller, despite anything to the contrary contained in the purchase order or represented by any agent or employee of Seller in writing or otherwise, notwithstanding, including but not limited to implied warranties.

THE FOREGOING REPAIR AND REPLACEMENT LIMITED WARRANTY IS IN LIEU OF ALL OTHER WARRANTIES, OBLIGATIONS AND LIABILITIES, INCLUDING, BUT NOT LIMITED TO, ALL WARRANTIES OF FITNESS FOR A PARTICULAR PURPOSE OR OF MERCHANTABILITY OR OTHERWISE, EXPRESSED OR IMPLIED IN FACT OR BY LAW, AND STATE SELLER'S ENTIRE AND EXCLUSIVE LIABILITY AND YOUR EXCLUSIVE REMEDY FOR ANY CLAIM IN CONNECTION WITH THE SALE AND FURNISHING OF SERVICES, GOODS OR PARTS, THEIR DESIGN, SUITABILITY FOR USE, INSTALLATION OR OPERATIONS. NEITHER ANY PERFORMANCE OR OTHER CONDUCT, NOR ANY ORAL OR WRITTEN INFORMATION, STATEMENT, OR ADVICE PREPARED BY SELLER OR ANY OF OUR EMPLOYEES OR AGENTS WILL CREATE A WARRANTY, OR IN ANY WAY INCREASE THE SCOPE OR DURATION OF THE LIMITED WARRANTY.

Disclaimer

Metric fasteners should not be used with ASME Class 150/300 bolt holes and flange bolt patterns. If you use metric fasteners with ASME Class 150/300 bolt holes and flange bolt patterns, it may lead to product failure, injury, and loss of life. DeZURIK Inc. disclaims all liability associated with the use of metric fasteners with ASME Class 150/300 bolt holes and flange patterns, including but not limited to personal injury, loss of life, loss of product, production time, equipment, property damage, lost profits, consequential damages of any kind and environment damage and/or cleanup. Use of metric fasteners with ASME Class 150/300 bolt holes and flange bolt patterns is a misuse that voids all warranties and contractual assurances. If you use metric fasteners with ASME Class 150/300 bolt holes and flange bolt patterns, you do so at your sole risk and any liability associated with such use shall not be the responsibility of DeZURIK, Inc. In addition to the foregoing, DeZURIK's Manufacturer's Conditions apply.

Limitation of Liability

IN NO EVENT SHALL SELLER BE LIABLE FOR ANY DIRECT, INDIRECT, SPECIAL, PUNITIVE, EXEMPLARY, OR CONSEQUENTIAL DAMAGES (INCLUDING, BUT NOT LIMITED TO; DAMAGE TO OR LOSS OF OTHER PROPERTY OR EQUIPMENT, BUSINESS INTERRUPTION, COST OF SUBSTITUTE PRODUCTS, LOSS OF TIME, LOSS OF PROFITS OR REVENUE, COST OF CAPTIAL, LOSS OF USE, OR DIMINUTION IN VALUE) WHATSOEVER, AND SELLER'S LIABILITY, UNDER NO CIRCUMSTANCES, WILL EXCEED THE CONTRACT PRICE FOR THE GOODS AND/OR SERVICES FOR WHICH LIABILITY IS CLAIMED. ANY ACTION FOR BREACH OF CONTRACT BY YOU, OTHER THAN RIGHTS RESPECTING OUR LIMITED WARRANTY DESCRIBED ABOVE, MUST BE COMMENCED WITHIN 12 MONTHS AFTER THE DATE OF SALE.

Sales and Service

For information about our worldwide locations, approvals, certifications and local representative:

Web site: www.dezurik.com E-Mail: info@dezurik.com



250 Riverside Ave. N., Sartell, MN 56377 • Phone: 320-259-2000 • Fax: 320-259-2227

DeZURIK, Inc. reserves the right to incorporate our latest design and material changes without notice or obligation.

Design features, materials of construction and dimensional data, as described in this manual, are provided for your information only and should not be relied upon unless confirmed in writing by DeZURIK, Inc. Certified drawings are available upon request.