

APCO ASV SEWAGE AIR/VACUUM VALVES AND DUAL BODY COMBINATION AIR VALVES

(BODY STYLES 401 & 401C)

ASV Air/Vacuum Valves Prevent Vacuum Conditions

APCO ASV-401 Air/Vacuum Sewage Air Valves are specifically designed for operation on sewage and waste media. Air/Vacuum Valves vent large volumes of air when the sewage line is filled and allow air to re-enter when draining to prevent vacuum or column separation from occurring.

Sewage Air/Vacuum Valves utilize two floats, each connected to a common stem which is guided through a bushing.

The upper float shuts off instantaneously against the seat, due to the impact zone and lifting force of the much larger concave bottom float, as sewage media enters the valve body. Once closed and pressurized, the Sewage Air/Vacuum Valve will not open to release air. It will open under negative pressure, allowing air to re-enter and prevent vacuum from forming in the line.

Dual Body Combination Sewage Air Valves

The ASV-401C Air/Vacuum Valve has an independent, side-connected Air Release Valve. The ASV-401C provides a large orifice for venting and admitting large volumes of air and a small orifice for releasing small pockets of air through the air release valve.

The Dual Body Combination Sewage Air Valve automatically releases collected pockets of air through the small orifice automatically while pressurized. Should a vacuum develop in the force main, both orifices open to permit large volumes of air to re-enter and break the vacuum.



Body Style 401
1-14" (25-350mm)

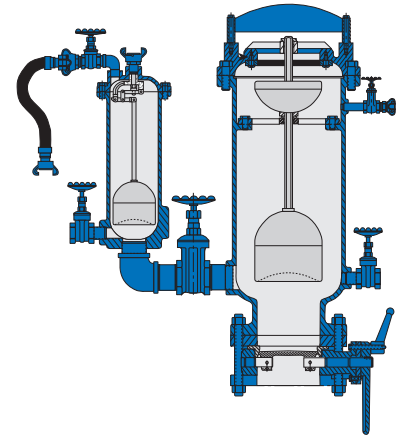

Body Style 401C
1-14" (25-350mm)

The large orifice air valve has an upper float and a lower concave bottom float. The valve maintains an air gap between the concave bottom float and upper shut-off float.

The small orifice air valve has a compound lever mechanism with a long float stem and stainless steel float. The elongated body maintains an air gap between the float and the mechanism.

The air gap prevents waste solids from clogging the upper shut-off float of the large orifice and the lever mechanism of the small orifice valve.

Stainless Steel Parts Prevent Corrosion

The float, venting mechanism, plug and seat are constructed of 316 stainless steel as standard to provide both corrosion resistance and trouble-free performance.

Concave Float

The concave bottom float is designed for optimum performance and reliability. ASV Combination Sewage Air Valves shut off drop tight to eliminate spills or spurts before shutting off. The concave float has a unique impact zone which is extremely sensitive to sewage media entering the Sewage Air Valve. The impact zone causes instantaneous and upward movement of the float to shut-off the discharge orifice as soon as media contacts the float. No spilling or spurting occurs even with low pressure (below 20 psi, 138 kpa).

NBR Seat Provides Tight Shutoff

The standard Acrylonitrile-Butadiene (NBR) seat is fastened to the valve cover to prevent distortion and provide drop-tight shut-off. Optional seat materials are EPDM (Terpolymer of Ethylene Propylene & A Diene) and FKM (Fluoro Rubber).

Compact Height

The height of the APCO Sewage Air Release Valve has been optimized to provide the best separation from media, while maintaining compact dimensions to minimize the need for deeper pipeline trenches and bigger valve vaults, saving costs.

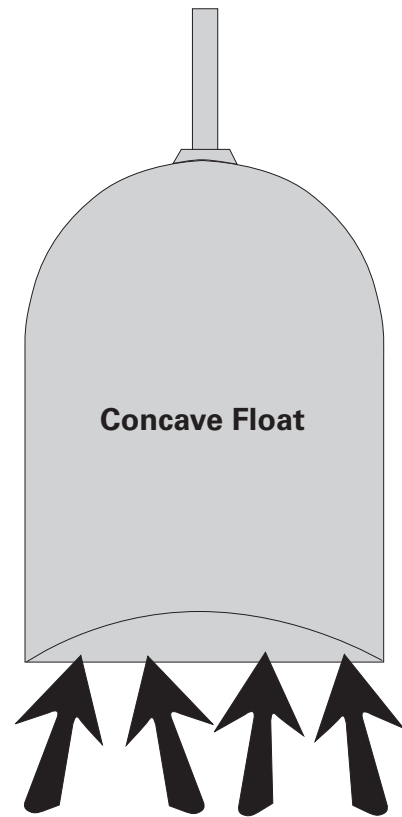

Impact Zone

Accessories

Backflush Kit (BFK)

The Backflush Kit is recommended for periodic cleaning of grease and scum from the Sewage Air Valve. The Backflush Kit is a separate item that includes two brass shut-off valves, 316 stainless steel piping, and 5 feet of hose with galvanized steel quick disconnect couplings. Contact DeZURIK if extra hose lengths are required. Maximum pressure of Back-Flush Kit is 200 psi. An isolation valve is required on the inlet port to isolate the valve while performing the backflush, but is not included. Contact DeZURIK for recommendations.

To order as part of a complete valve, add BFK to the valve order code.

Ordering Example:

ASV,3,401,T1,DI,125,NBR-S2-S2*BFK

Order as a separate item by giving order code from table.

Order Code	Description
ACC*BFK-ASV401	Backflush Kit for ASV-401 Valves
ACC*BFK-ASV401C	Backflush Kit for ASV-401C Valves

Ordering Example:

ACC*BFK-ASV401

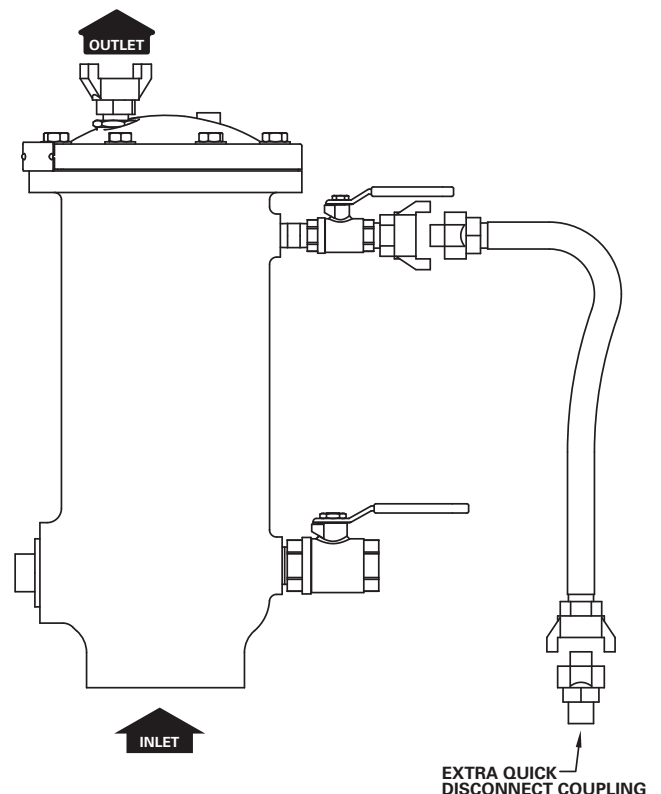

Mushroom Cap (MRC)

The Mushroom Cap prevents foreign debris from entering the valve outlet while providing wide openings for free expulsion of air. Available on valve sizes 1-3" (25-75mm). To order as part of a complete valve, add MRC to order code.

Ordering Example:

ASV,3,401,T1,DI,125,NBR-S2-S2*MRC

To order as a separate item, give order code from the table below.

Outlet Size	Body Material	
	DI or CS	S2
1" NPT	ACC*MRC-1	ACC*MRCFB-1
2" NPT	ACC*MRC-2	ACC*MRCFB-2
3" NPT	ACC*MRC-3	ACC*MRCFB-3

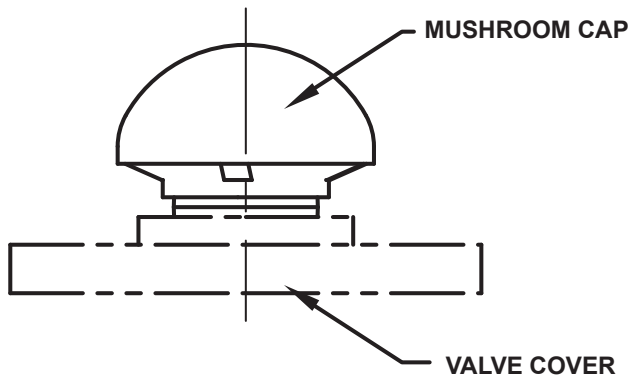

Double Acting Throttling Device (DAT)

The APCO Double Acting Throttling Device (DAT) is designed to regulate and restrict air venting on the discharge orifice of the ASV Dual Body Combination Air Valve. The DAT features an exclusive throttling air-out/full flow air-in design. On pump start, the device establishes a pressure load on the rising column of media to eliminate shock to the pump, controls and check valve. On pump stop, the DAT device automatically opens to allow full line, unrestricted air reentry to prevent a vacuum and water column separation in the pump.

The DAT has a fusion bonded epoxy coating. It can be ordered as part of a complete valve, or as a separate item. The DAT is not a stand-alone device and cannot be installed directly to the pipeline; it must be installed in the outlet port (top) of the Air/Vacuum Valve.

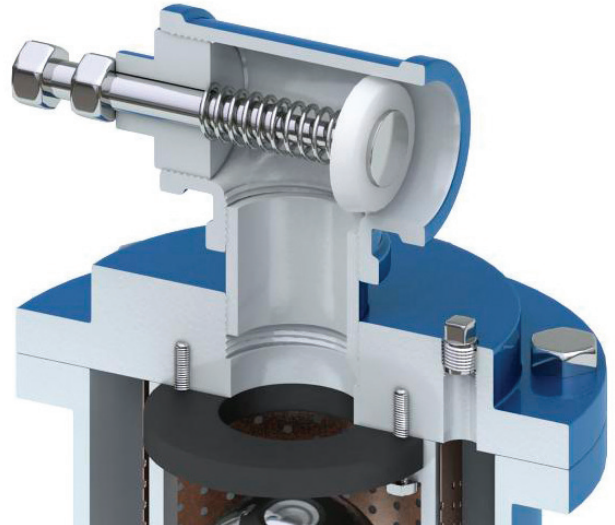

To order as part of a complete valve, add DAT to the valve order code.

Ordering Example:

ASV,3,401,T1,DI,125,NBR-S2-S2*DAT

To order as a separate item, give order code from the table below.

Valve Size	Body Material	
	DI or CS	S2
1.2" 25mm	ACC*DAT-1.2	ACC*DATFB-1.2
2" 50mm	ACC*DAT-2	ACC*DATFB-2
3" 80mm	ACC*DAT-3	ACC*DATFB-3
4" 100mm	ACC*DAT-4	ACC*DATFB-4
6" 150mm	ACC*DAT-6	ACC*DATFB-6
8" 200mm	ACC*DAT-8	ACC*DATFB-8

Materials of Construction

Item	Description	Material
A01	Body	Ductile Iron, ASTM A536
A02	Cover	316 Stainless Steel, ASTM A351/A743 CF-8M
A03	Cover Gasket	Cell Cork Fiber
A04	Cover Bolts	Zinc-Plated Carbon Steel
A06	Seat	Acrylonitrile-Butadiene (NBR) Terpolymer of Ethylene Propylene & A Diene (EPDM) Fluoro Rubber (FKM)
A05	Guide Plate	316 Stainless Steel
A14	Upper Float	316 Stainless Steel
A15	Lower Float	316 Stainless Steel
A16	Seat Retaining Screw	316 Stainless Steel
A21	Lock Washer	18-8 Stainless Steel
A24	Baffle	316 Stainless Steel
A26	Lower Guide Bushing	316 Stainless Steel
A28	Hood	Steel
A29	Hood Screws	Carbon Steel
A33	Float Stem	316 Stainless Steel
A34	Baffle/Guide Plate Screw	316 Stainless Steel
A38	Float Set Screw	316 Stainless Steel
A40	Bumper	Acrylonitrile-Butadiene (NBR) Terpolymer of Ethylene Propylene & A Diene (EPDM) Fluoro Rubber (FKM)
A41	Float Guide	316 Stainless Steel
A43	Upper Guide Bushing	316 Stainless Steel
A44	1/2" NPT Pipe Plug	Steel
A45	1" NPT Pipe Plug	Iron
A46	2" NPT Pipe Plug	Iron
A50	Inlet Nipple	Steel
A51	Inlet Flange	Steel
A54	Outlet Nipple	Steel
A55	Outlet Flange	Steel
A58	Bug Screen	304/316 Stainless Steel
A59	Cover Washers*	Carbon Steel
A60	Baffle/Guide Plate Washers*	316 Stainless Steel
A61	Hood Washers*	316 Stainless Steel

For Dual Body Combination Valves, refer to Bulletin 400-1 for Materials of Construction for the Air Release Valve.

*Only provided on valves that either have fusion bonded epoxy or interior and exterior coating specified.

1.2-3" Valves

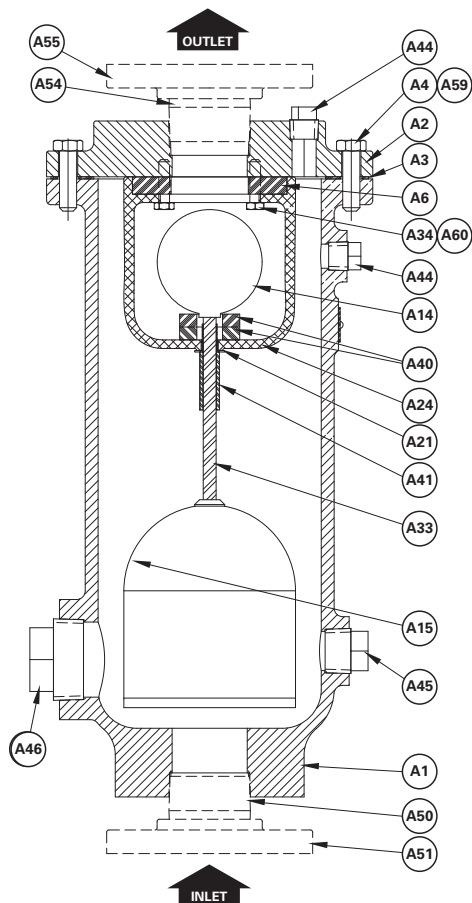

4-14" Valves

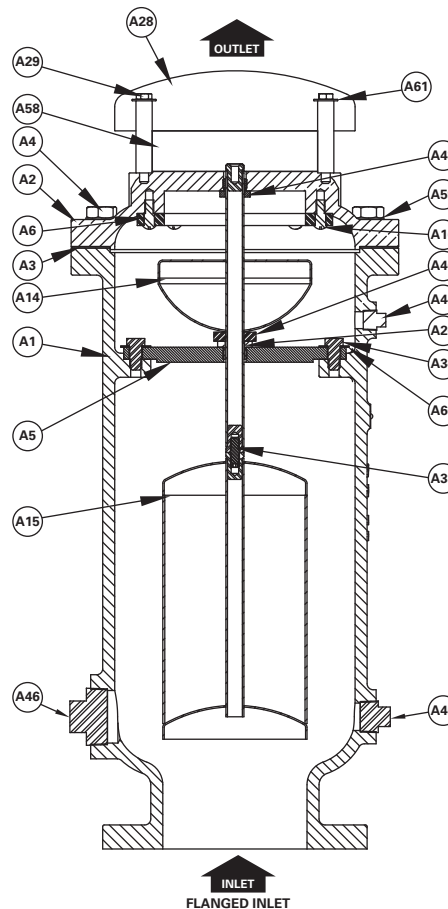

Valve Selection

Temperature Rating

All valves are rated to a maximum temperature of at least 250° F (121° C).

Contact application engineering if the valve is required to operate above this temperature.

Pressure Rating

APCO ASV Sewage Air/Vacuum Valves are rated for 150 psi (1035 kPa)

Performance Graphs For Air/Vacuum Valve

Graphs show air inflow/outflow through valve in standard cubic feet of free air per second (scfs). Curves shown are actual flow capacities at 14.7 psi barometric pressure and 70°F temperature based on actual test. These figures are not merely flow capacities across the orifice, but flow capacities across the entire valve. In the test set-up, air approach velocity is negligible, therefore actual flow capacity exceeds the values shown on chart.

Weights

Valve Size	Valve Only	With Backflush Kit
1" 25mm	41 19	55 25
2" 50mm	85 39	115 52
3" 80mm	85 39	118 54
4" 100mm	130 59	200 91
6" 150mm	190 86	290 132
8" 200mm	310 141	430 195
10" 250mm	600 272	800 363
12" 300mm	750 340	980 445
14" 350mm	950 431	1230 558

Lbs
Kg

Inflow

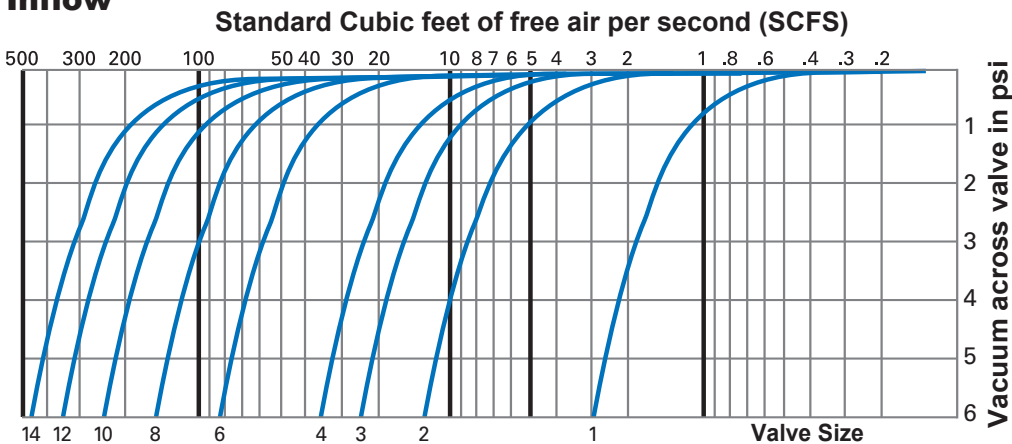

Outflow

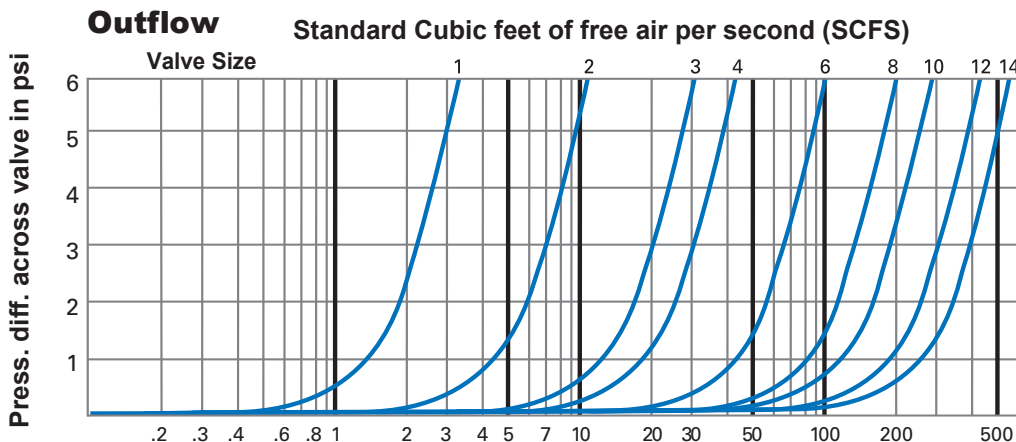

Venting Capacity Graph for Dual Body Combination Air Valves

Venting Capacity Graph for Air Release Valves

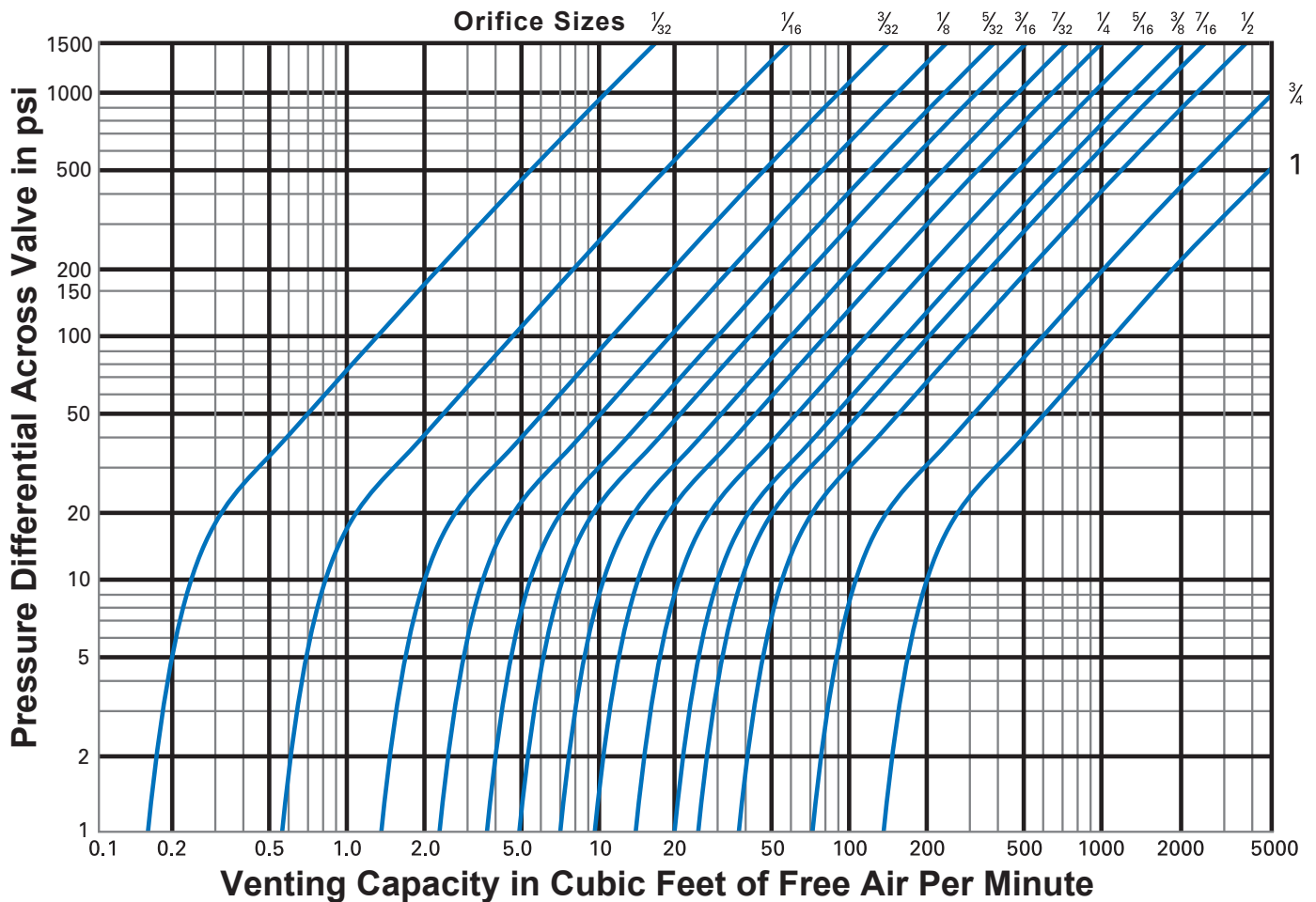

Note: Limiting Factor for Working Pressure is lowest pressure rating of end connection or orifice size.

Pressure Ratings (ambient temperature) and Venting Capacity

Limiting factory for Working pressure is the lowest pressure rating of the end connection, valve rated pressure and orifice pressure rating.

Body Style 401C

Body Style	Valve Size	Body Material	End Connection	Orifice Code	Orifice Diameter	Minimum Rated Pressure (psi)	Maximum Rated Pressure (psi)	Venting Capacity (CFFAM)	
400	1-4"	DI	T1 & F1N	L516	5/16"	3	15	25	
				R516	5/16"	11	50	65	
				R14	1/4"	11	75	65	
				R316	3/16"	11	150	60	
	6-14"	DI*	F1	T1	R532	5/32"	11	300	75
				F1N	R532	5/32"	11	250*	65
450	2-4"	DI	T1 & F1N	L12	1/2"	3	15	60	
				R12	1/2"	11	75	225	
				H12	1/2"	51	150	450	
				T1	R716	7/16"	76	300	550
	6-14"	DI*	F1	F1N	R716	7/16"	76	250*	65
				F1	R716	7/16"	76	250*	65

*Valve maximum rated pressure at ambient temperature with a flanged inlet for Carbon Steel Valves is 285 psi; stainless steel valves is 275 psi.

Ordering

Orders must specify quantity and order code identification, in proper sequence, as shown.

<p>Valve Style Give valve style code as follows:</p> <p>ASV = Sewage Air/Vacuum Valves</p>

<p>Valve Size Give valve size code as follows:</p> <table> <tr> <td>1.2 = 1"</td> <td>25mm</td> <td>8 = 8"</td> <td>200mm</td> </tr> <tr> <td>2 = 2"</td> <td>50mm</td> <td>10 = 10"</td> <td>250mm</td> </tr> <tr> <td>3 = 3"</td> <td>80mm</td> <td>12 = 12"</td> <td>300mm</td> </tr> <tr> <td>4 = 4"</td> <td>100mm</td> <td>14 = 14"</td> <td>350mm</td> </tr> <tr> <td>6 = 6"</td> <td>150mm</td> <td></td> <td></td> </tr> </table>	1.2 = 1"	25mm	8 = 8"	200mm	2 = 2"	50mm	10 = 10"	250mm	3 = 3"	80mm	12 = 12"	300mm	4 = 4"	100mm	14 = 14"	350mm	6 = 6"	150mm		
1.2 = 1"	25mm	8 = 8"	200mm																	
2 = 2"	50mm	10 = 10"	250mm																	
3 = 3"	80mm	12 = 12"	300mm																	
4 = 4"	100mm	14 = 14"	350mm																	
6 = 6"	150mm																			

<p>Body Style Give body style code as follows:</p> <p>401 = 1.2-3" NPT Outlet 4-14" Plain Outlet with Hood</p> <p>401C = 1.2-3" Dual Body, NPT Outlet 4-14" Dual Body, Plain Outlet w/ Hood</p>
--

<p>End Connection Give end connection code as follows:</p> <p>T1 = Threaded Inlet NPT (1.2-4")</p> <p>F1N = Flanged Inlet ASME 125/150 (1.2-4") with Carbon Steel Nipple & Flange</p> <p>F1 = Flanged Inlet ASME 125/150 (6-14") Cast</p>
--

<p>Body Material Give body material code as follows:</p> <p>DI = Ductile Iron (1.2-10")</p> <p>CS = Carbon Steel (12-14")</p> <p>S2 = 316 Stainless Steel</p>
--

<p>Cold Working Pressure Give working pressure code as follows:</p> <p>15 = 1.2-14" 3-15 psi All Body Material</p> <p>125 = 1.2-10" 11-200 psi, DI Body Material</p> <p>150 = 12&14" 11-285 psi, CS Body Material</p> <p>On Application</p> <p>150 = 1.2-10" 11-250 psi, DI Body Material 1.2-14" 11-275 psi, S2 Body Material</p> <p>Note: Working pressure is de-rated at temperatures over 100° F.</p>
--

<p>Trim Combination</p>

<p>Seating Surface Give seating surface material code as follows:</p> <p>NBR = Acrylonitrile-Butadiene</p> <p>EPDM = Terpolymer of Ethylene Propylene & A Diene</p> <p>FKM = Fluoro Rubber</p> <p>Note: Needle Material will be the same as Seating Surface</p>

<p>Baffle Material Give baffle material code as follows:</p> <p>S2 = 316 Stainless Steel (1.2-3")</p> <p>NA = Not Required (4-14")</p>

<p>Float Material Give float material code as follows:</p> <p>S2 = 316 Stainless Steel</p>

<p>Air Release Valve Orifice Size Give air release code as follows if required:</p> <p>Body Style 401C Only – Not required on other Body Style</p> <p>L516 = 5/16" 3-15 psi, 2" Body Style 400 (Available with 15 CWP only)</p> <p>R516 = 5/16" 11-50 psi 2" Body Style 400</p> <p>R14 = 1/4" 11-75 psi 2" Body Style 400</p> <p>R316 = 3/16" 11-150 psi 2" Body Style 400</p> <p>R532 = 5/32" 11-300 psi 2" Body Style 400</p> <p>L12 = 1/2" 3-15 psi 2" Body Style 450 (Available with 15 CWP only)</p> <p>R12 = 1/2" 11-75 psi 2" Body Style 450</p> <p>H12 = 1/2" 51-150 psi 2" Body Style 450</p> <p>R716 = 7/16" 76-300 psi 2" Body Style 450</p> <p>Note: Limiting Factor for Working Pressure is lowest Pressure Rating of end connection or orifice size.</p>
--

<p>Options Give option code as follows if required:</p> <p>DTR = DeZURIK Standard Certified Production Hydrostatic Shell & Seat Test Report</p> <p>FL = Flanged Outlets ASME 125/150, 1.2-3" are CS Nipple & CI Flange with DI body material, all others are the same as the body material.</p> <p>HSB = Bug Screen for Hood, 304 Stainless Steel (4-14")</p> <p>HSR = Rock Screen for Hood, 304 Stainless Steel (4-14")</p> <p>SB16 = 316 Stainless Steel Bolting</p> <p>TH = Threaded Outlet NPT (4-8"), same material as the body</p> <p>— = Standard Coating on ASV-401 Valves is 2-part epoxy on exterior. Standard coating on ASV-401C is fusion bonded epoxy on interior and exterior.</p> <p>Contact DeZURIK if alternate coatings are required.</p>

<p>Accessories Give accessory code as follows if required:</p> <p>BFK = Backflush Kit (200 psi maximum)</p> <p>DAT = Double Acting Throttling Device (1.2-8") 4-8" must use TH option code</p> <p>MRC = Mushroom Cap (1.2-3"). Not available with FL Option.</p>

Ordering Example:
ASV,3,401,T1,DI,125,NBR-S2-S2*BFK-MRC

Dimensions

Air/Vacuum Valve Only, Body Style 401

Outlet Size	Inlet Size	A	B	C	D	E	F	G	H	J
1" 25mm	2"	16.38 416	7.00 178	4.50 114	3.50 89	3.00 76	0.94 24	—	—	1.69 43
2" 50mm	2"	19.75 502	9.63 245	5.63 143	4.06 103	4.06 103	1.69 43	—	—	1.69 43
3" 80mm	3"	19.75 502	9.63 245	5.69 145	4.06 103	4.06 103	1.88 48	—	—	1.88 48
4" 100mm	4"	29.63 753	11.00 279	5.75 146	4.81 122	4.56 116	—	27.63 702	28.00 711	2.06 52
6" 150mm	6"	32.44 824	13.63 346	7.00 178	5.88 149	5.88 149	—	30.25 768	30.50 775	—
8" 200mm	8"	36.50 927	17.25 438	9.00 229	7.88 200	7.88 200	—	33.63 854	34.13 867	—
10" 250mm	10"	40.75 1035	20.00 508	9.75 248	8.75 222	8.75 222	—	38.88 988	—	—
12" 300mm	12"	47.69 1211	25.00 635	11.69 297	10.50 267	10.50 267	—	43.88 1115	—	—
14" 350mm	14"	51.25 1302	29.00 737	13.50 343	13.00 330	13.00 330	—	48.38 1229	—	—

Inches
Millimeters

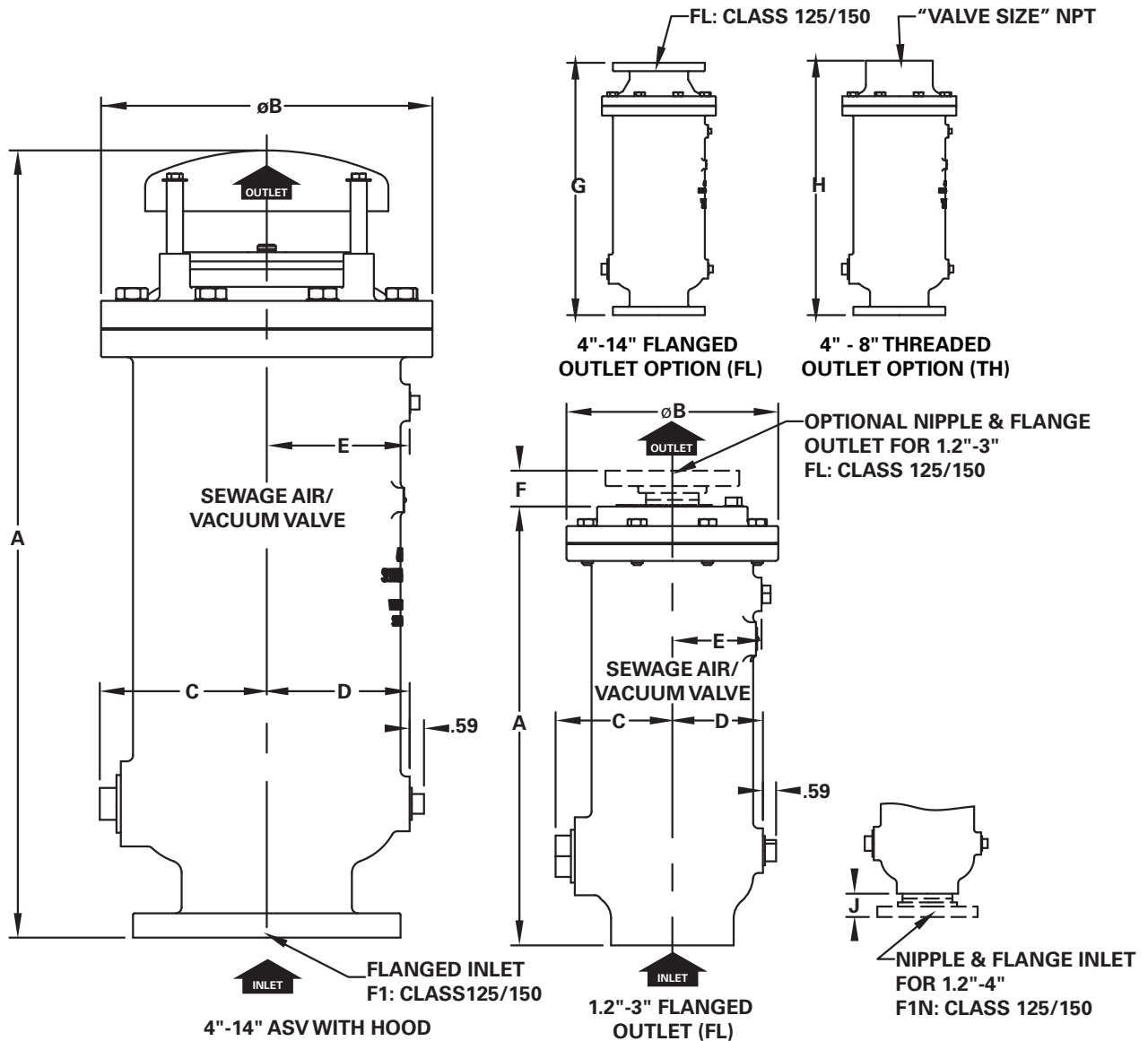

Dimensions

Dual Body Combination Air Valve, Body Style 401C, 1-3"

Outlet Size	Inlet Size	A	B		C	D	E	
			ASR-400	ASR-450			ASR-400	ASR-450
1" 25mm	2"	16.25	17.57	18.82	0.94	1.69	21.79	24.35
		413	446	478	24	43	553	618
2" 50mm	2"	19.75	19.57	20.82	1.69	1.69	24.54	27.10
		502	497	529	43	43	623	688
3" 80mm	3"	19.75	19.57	20.82	1.88	1.88	24.54	27.10
		502	497	529	48	48	623	688

Inches
Millimeters

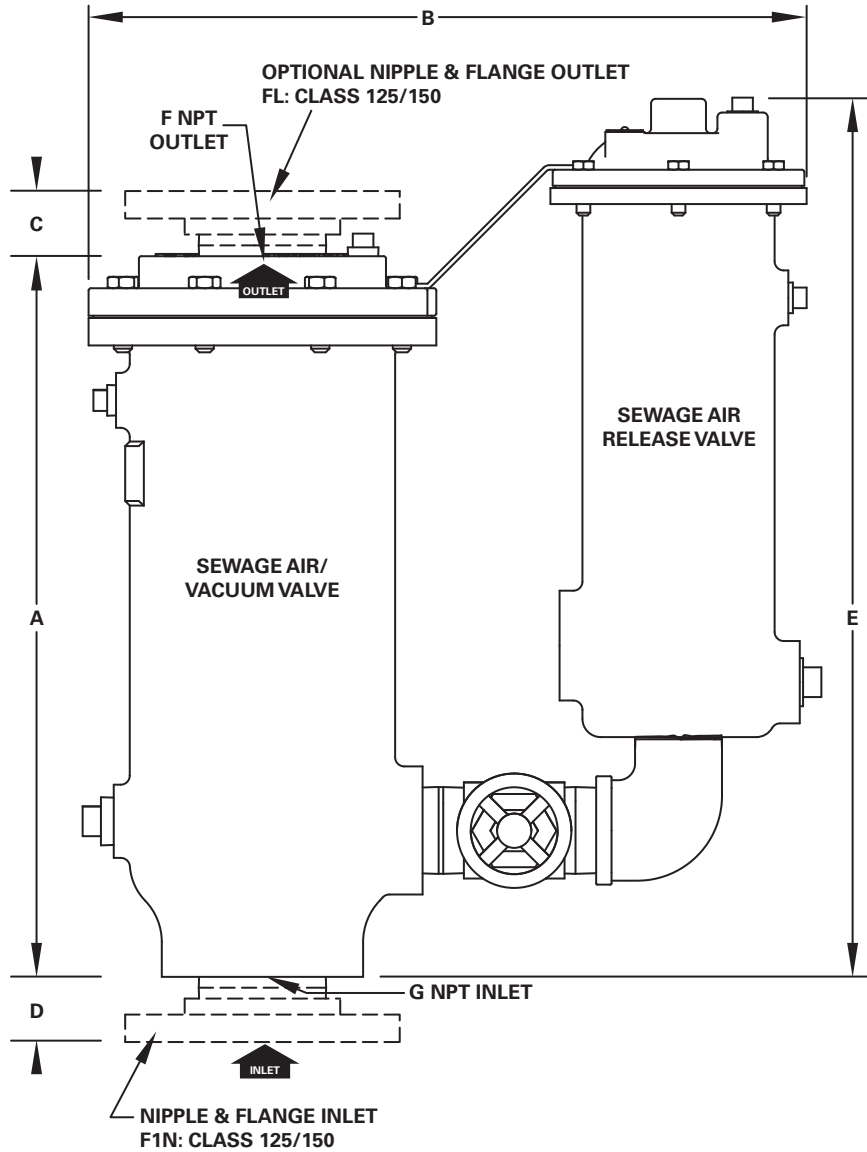

Dimensions

Dual Body Combination Air Valve, Body Style 401C, 4-8" Threaded Outlet

Outlet Size	Inlet Size	A		B	C		D
		ASR-400	ASR-450		ASR-400	ASR-450	
4" 100mm	4"	21.07	22.32	28.00	24.79	27.35	2.06
		535	567	711	630	695	52
6" 150mm	6"	23.57	24.82	30.50	25.79	28.35	—
		599	630	775	655	720	—
8" 200mm	8"	27.38	28.63	34.13	26.79	29.35	N/A
		696	727	867	681	746	N/A

Inches
Millimeters

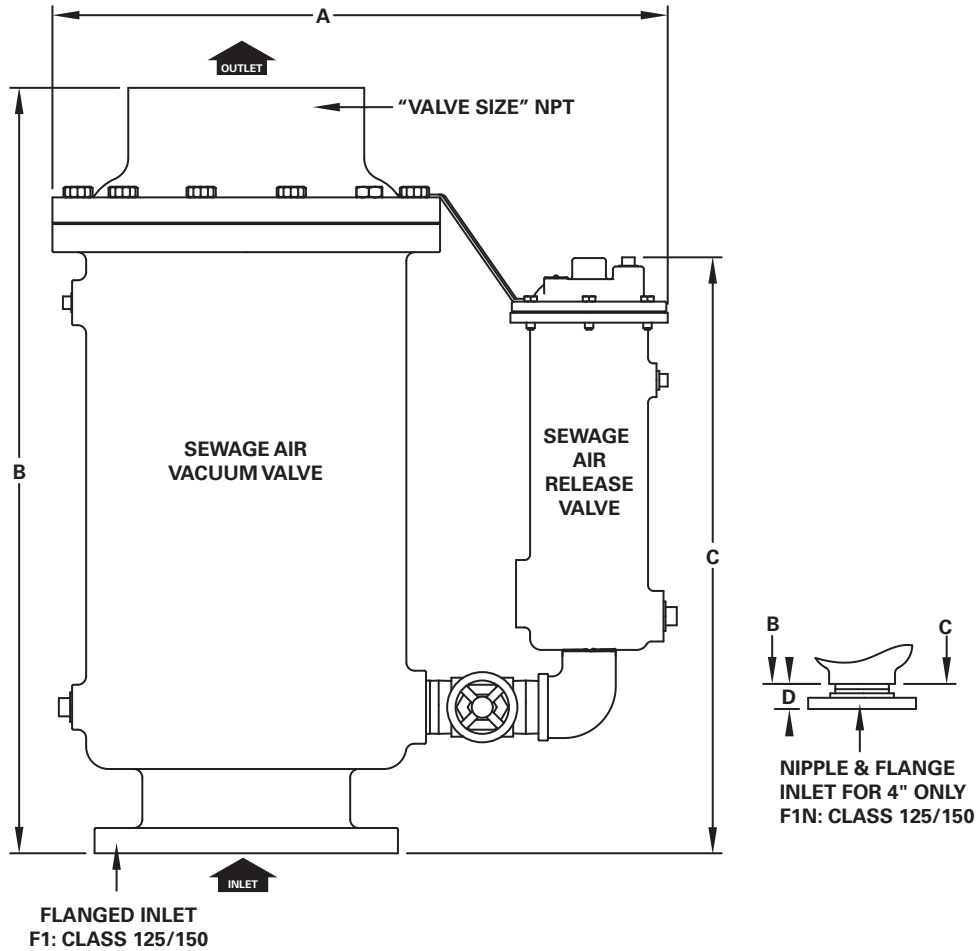

Dimensions

Body Style 401C, 4-14" Flanged Inlet (F1/F1N)

Outlet Size	Inlet Size	A		B		C		D
		ASR-400	ASR-450	Plain Outlet	Flanged Outlet	ASR-400	ASR-450	
4" 100mm	4"	21.07	22.32	29.63	27.63	24.79	27.35	2.06 52
		535	567	753	702	630	695	
6" 150mm	6"	23.57	24.82	32.44	30.25	25.79	28.35	—
		599	630	824	768	655	720	
8" 200mm	8"	27.38	28.63	36.50	33.63	26.79	29.35	—
		695	727	927	854	680	745	
10" 250mm	10"	29.51	30.76	40.75	38.88	26.79	29.35	—
		750	781	1035	988	680	745	
12" 300mm	12"	33.76	35.01	47.69	43.88	27.29	29.85	—
		858	889	1211	1115	693	758	
14" 350mm	14"	38.76	40.01	51.25	48.38	28.04	30.60	—
		985	1016	1302	1229	712	777	

Inches
Millimeters

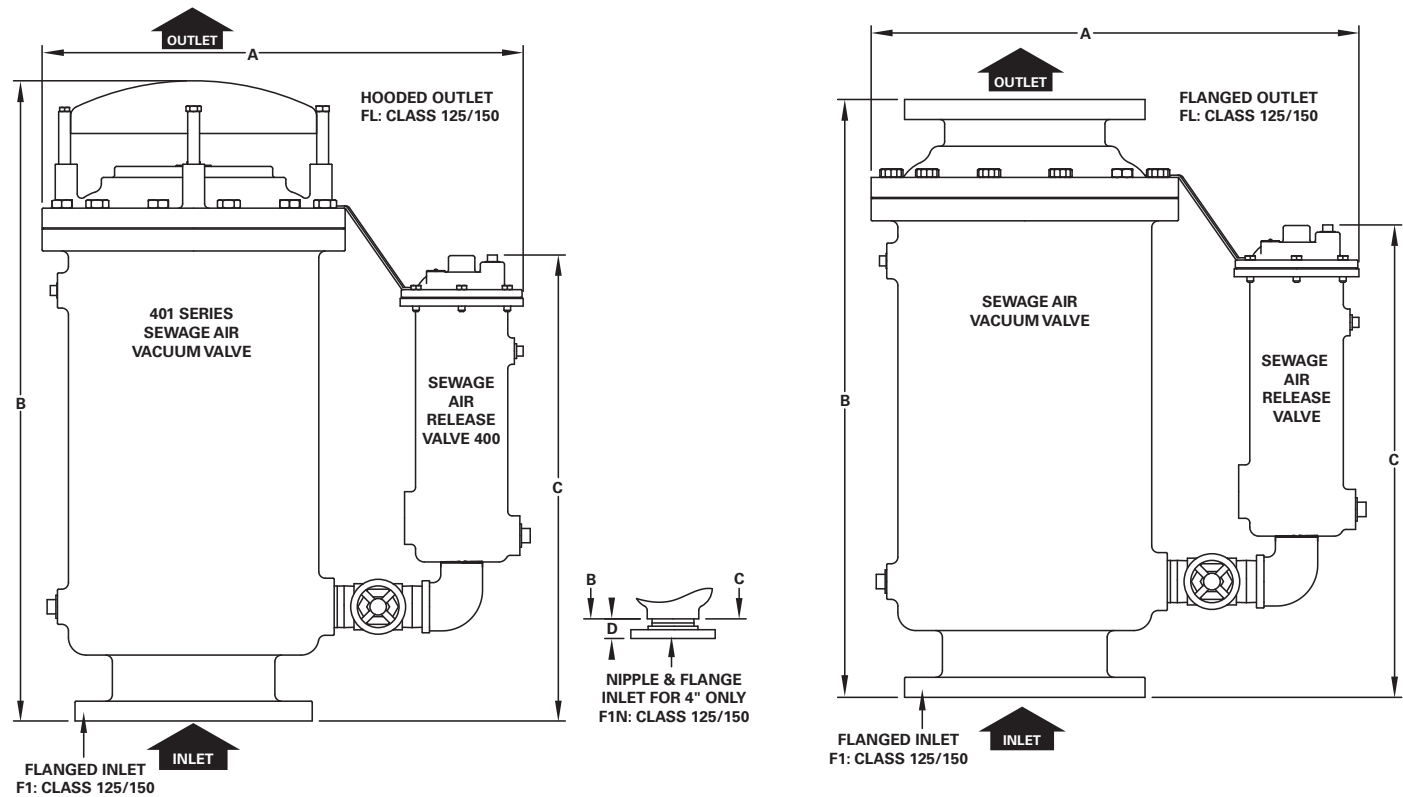

Sales and Service

For information about our worldwide locations, approvals, certifications and local representative:

Web Site: DeZURIK.com E-Mail: info@DeZURIK.com



250 Riverside Ave. N. Sartell, Minnesota 56377 • Phone: 320-259-2000 • Fax: 320-259-2227

DeZURIK, Inc. reserves the right to incorporate our latest design and material changes without notice or obligation. Design features, materials of construction and dimensional data, as described in this bulletin, are provided for your information only and should not be relied upon unless confirmed in writing by DeZURIK, Inc. Certified drawings are available upon request.