

DeZURIK PEF 100% PORT ECCENTRIC PLUG VALVES TECHNICAL SPECIFICATIONS



Materials of Construction

A1	Body	Cast Iron, ASTM A126, Class B Ductile Iron, ASTM A536
A2	Body Bearing	316L Stainless Steel, Sintered Stainless Steel
A3	Plug	Metal, (Ductile Iron, ASTM A536, Grade 65-45-12)
		CR Chloroprene
		NBR Acrylonitrile-Butadiene CIIR Chloro-Isobutene-Isoprene
A4	Grit Excluder	PTFE
A5	O-Ring	Non-asbestos filler in Styrene-Butadiene Rubber binder (NBR)
A6	Bonnet	Same as body material 3-24"; Ductile Iron ASTM A536 30" & 36"
A7	Bonnet Bearing	316L Stainless Steel, Sintered Stainless Steel
A8	Bonnet Screws	Carbon Steel, Class 8.8, Zinc Plated
		Stainless Steel, Grade A2, (18-8)
		Stainless Steel, Grade A4, (316)
A9	Packing	NBR Acrylonitrile-Butadiene, V-Type PTFE
A10	Key	Steel, ASTM A108
A11	Gland	Cast Iron, ASTM A126, Class B
A12	Gland Stud	Carbon Steel, Class 8.8, Zinc Plated
		Stainless Steel, Grade A2, (18-8)
		Stainless Steel, Grade A4, (316)
A13	Nut	Carbon Steel, Zinc Plated
		Stainless Steel, A2, (18-8)
		Stainless Steel, A4, (316)
A14	Caution Tag	Stainless Steel
A15	Pipe Plug (optional)	Galvanized Carbon Steel
A16	O-Ring	Non-asbestos filler in Styrene-Butadiene Rubber binder (NBR)
A17	Journal Cover	Cast Iron, ASTM A126, Class B
		Carbon Steel, ASTM A36 (Used with DI Body)
A18	Screw	Carbon Steel, Class 8.8, Zinc Plated
		Stainless Steel, Grade A2, (18-8)
		Stainless Steel, Grade A4, (316)
A21	Friction Cone	Ryton
A23	Pipe Plug (optional)	Galvanized Carbon Steel 316 Stainless Steel

Flanged Construction 3" (80mm) and Larger

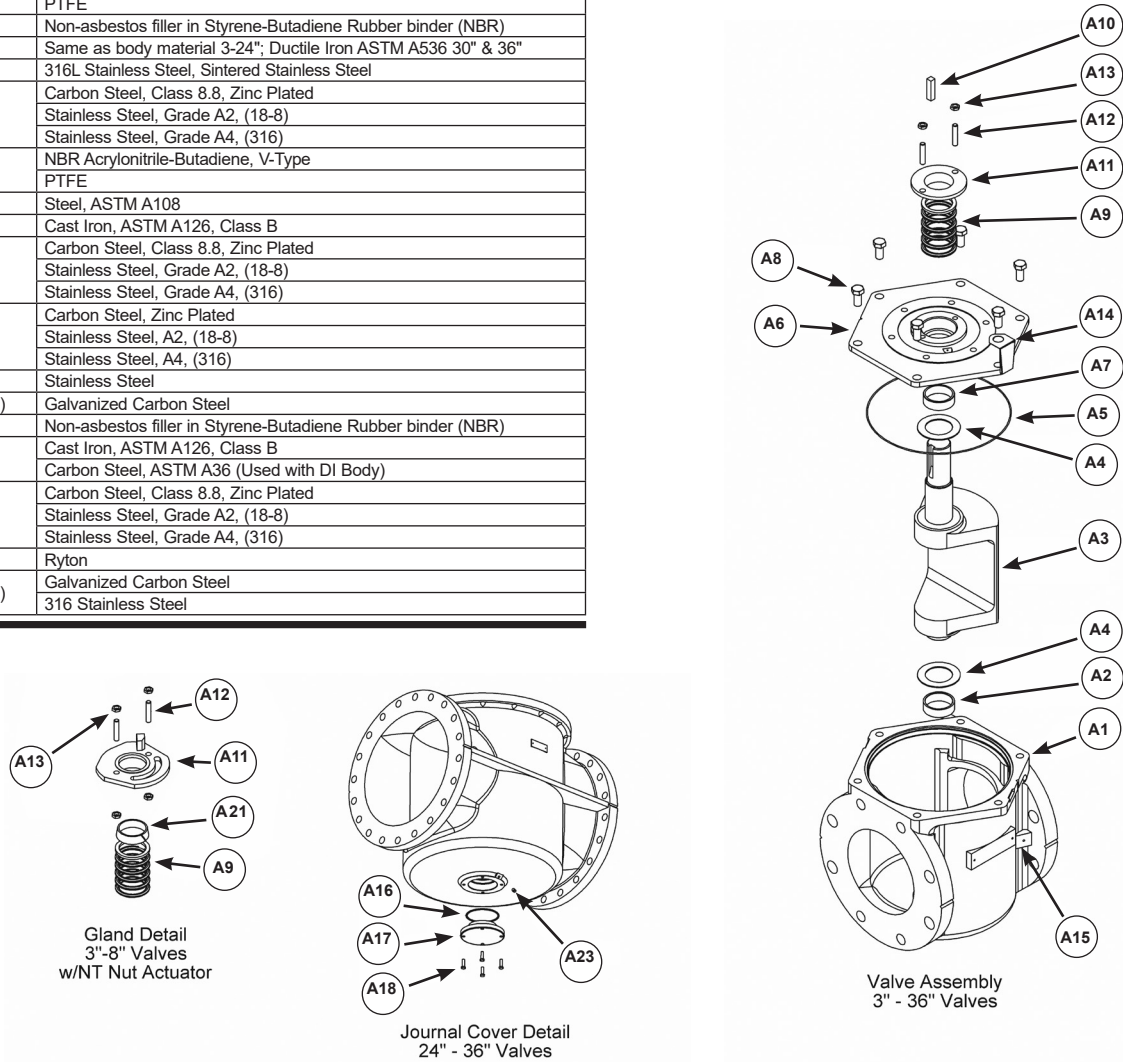

Applicable Standards

DeZURIK PEF 100% Port Eccentric Plug Valves are designed and/or tested to meet the following standards:

AWWA C517-16 Resilient-Seated Cast-Iron Eccentric Plug Valve.

ASME flange drilling conforms to ASME B16.1 Class 125, ASME B16.5 Class 150, and ASME B16.42 Class 150. Mechanical-joint end connections conform to AWWA C111/A21.11.

MSS-SP91 guidelines for manual operation of valves.

Metric 10 bar flange drilling conforms to the NP 10 requirements of International Standard ISO 2084, to the 10 bar requirements of British Standard 4504, and to the NP 10 requirements of German Standard DIN 2532.

Metric 16 bar flange drilling conforms to the NP 16 requirements of International Standard ISO 2084, to the 16 bar requirements of British Standard 4504, and to the NP 16 requirements of German Standard DIN 2533.

British Table D flange drilling and Table E flange drilling conform to British Standard BS 10.

Japanese 10 bar flange drilling conforms to Japanese Industrial Standard JIS B 0203.

* Patent Pending

Valve Selection

Pressure Ratings

C.W.P. Non-Shock Working Pressure Ratings

Material	Valve Size	
	3-12" (80-300mm)	14-36" (350-900mm)
Cast Iron or Ductile Iron	175 psi 1210 kPa	150 psi 1035 kPa

* Cast Iron conforms to ASME B16.1 Class 125 Hydrostatic Test.

Cv/Kv Values

Valve Size	Cv* Kv*
3" 80mm	880 760
4" 100mm	1160 1000
5 & 6" 125 & 150mm	1960 1700
8" 200mm	3100 2680
10" 250mm	4540 3930
12" 300mm	6300 5450
14" 350mm	7560 6530
16" 400mm	9840 8500
18" 450mm	12500 10800
20" 500mm	15400 13300
24" 600mm	41400 35800
30" 750mm	65500 56600
36" 900mm	95100 82200

* Cv = Flow in GPM of water at 1 psi pressure drop.
* Kv = Flow in m³/hr. of water at 100 kPa pressure drop.

Basic Valve Weights

Valve Size	Flanged lbs/kg	Mechanical Joint lbs/kg
3" 80mm	57 26	60 27
4" 100mm	72 33	82 37
5" 125mm	120 54	N/A
6" 150mm	120 54	138 63
8" 200mm	185 84	207 94
10" 250mm	264 120	296 134
12" 300mm	375 170	395 179
14" 350mm	555 252	595 270
16" 400mm	698 317	784 356
18" 450mm	1015 460	1091 495
20" 500mm	1340 608	1389 630
24" 600mm	3160 1433	2984 1354
30" 750mm	5305 2406	5145 2334
36" 900mm	8225 3731	8110 3679

Note: Basic Valve – is a fully assembled bare shaft valve

Flow Characteristic

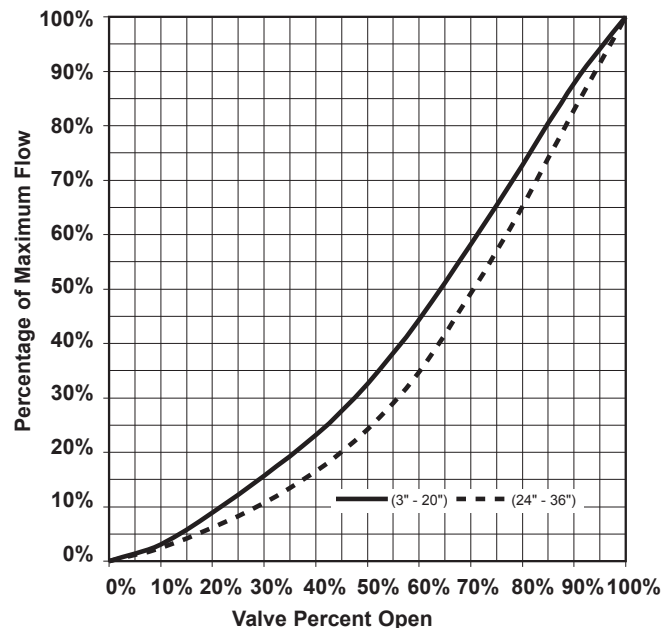

Valve Selection

Flow Charts

Valve Fully Open

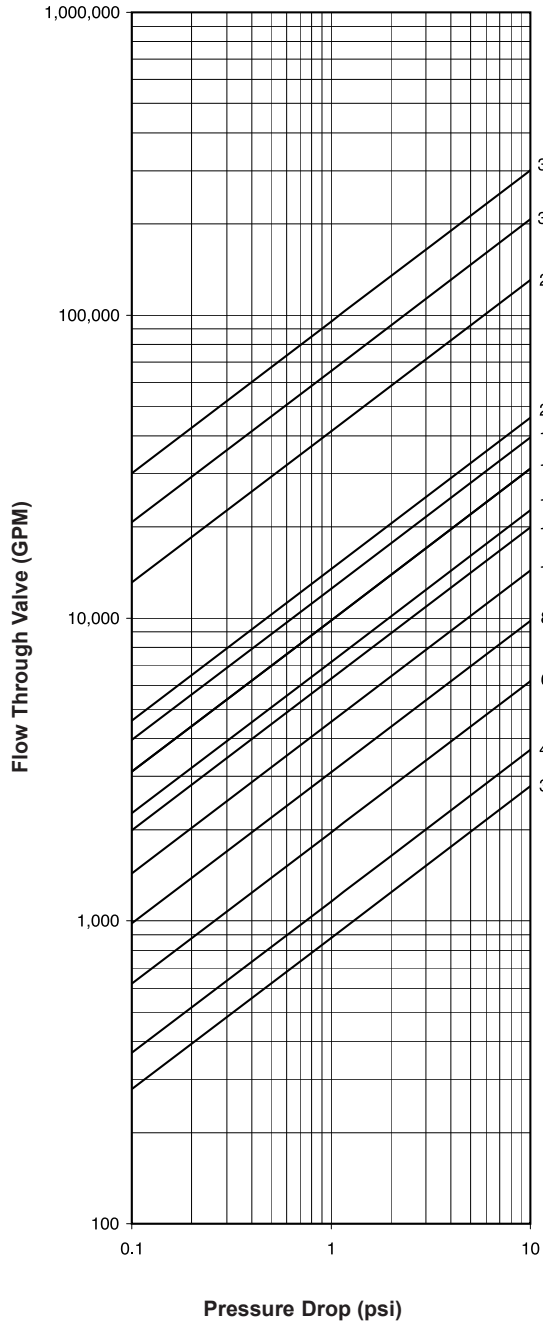

Valve Fully Open - Metric

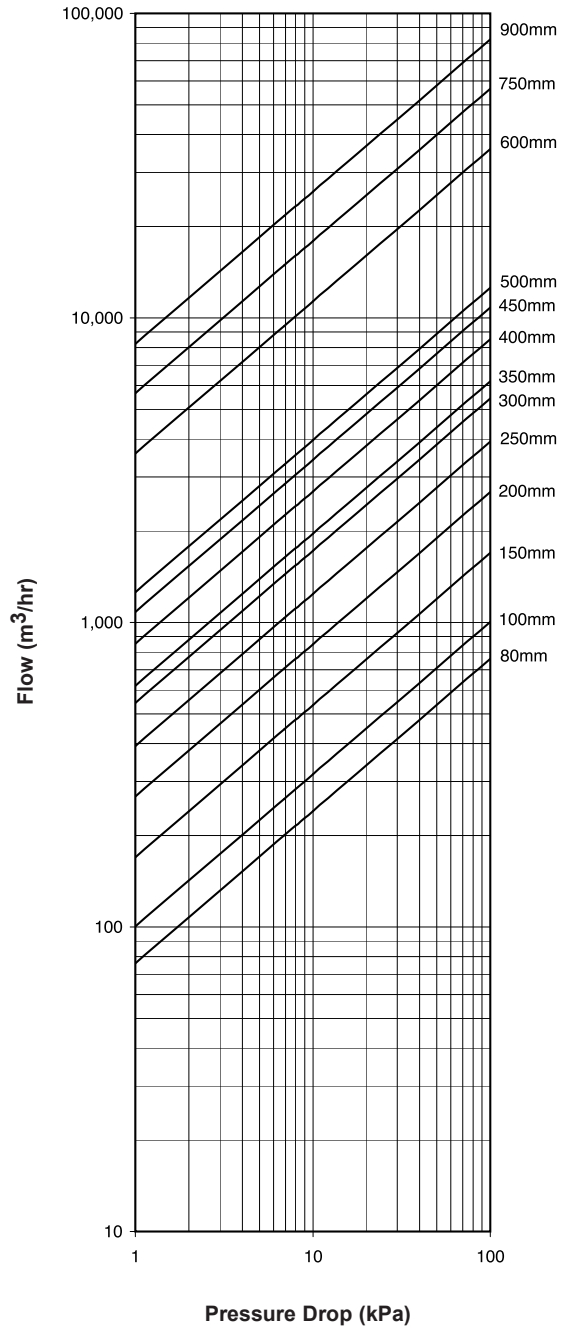

Installation Instructions

Clean Liquids and Clean Gases

The proper installation of a DeZURIK PEF 100% Eccentric Plug Valve in clean liquids and gases applications is with the higher pressure against the end opposite the seat.

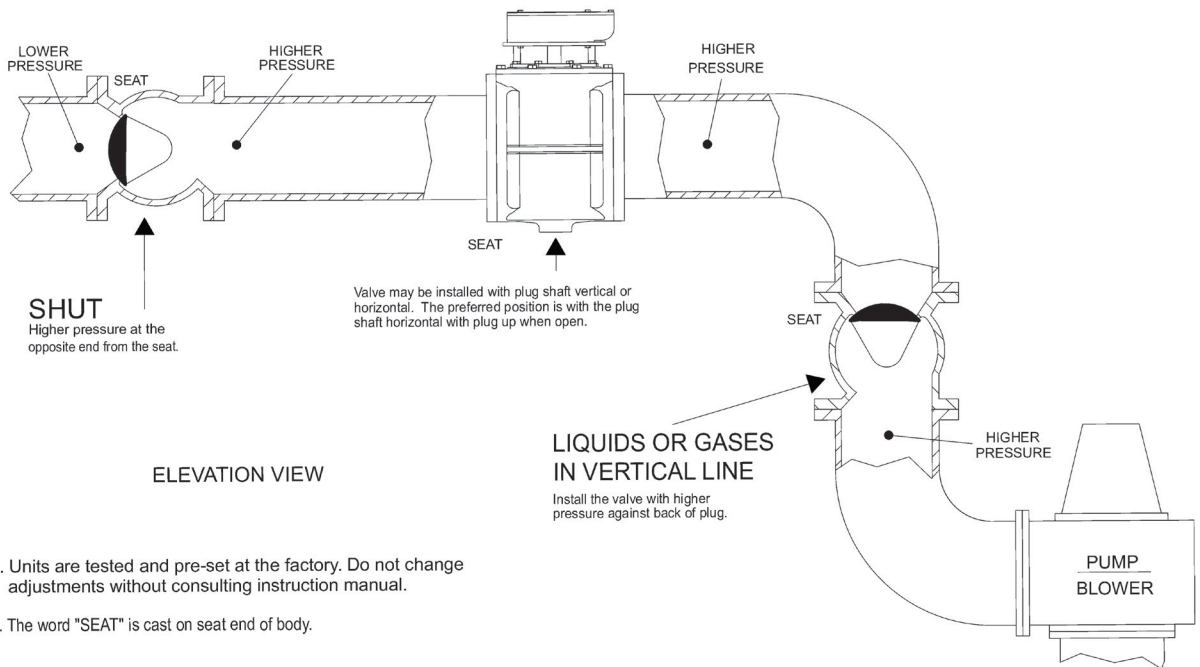

NOTE - 1. Units are tested and pre-set at the factory. Do not change adjustments without consulting instruction manual.

2. The word "SEAT" is cast on seat end of body.

Liquids with Suspended Solids and Dirty Gases

The proper installation of a DeZURIK PEF 100% Eccentric Plug Valve in suspended solids applications such as raw sewage is critical to prevent solids from packing into the valve body, restricting the plug movement. This can be accomplished by installing the valve with the flow against the face of the plug in the closed position and the valve on its side with the plug rotating to the top of the pipeline in the open position. For pump isolation service, install the valve with the seat side opposite the pump and with the plug rotating to the top of the pipeline in the open position.

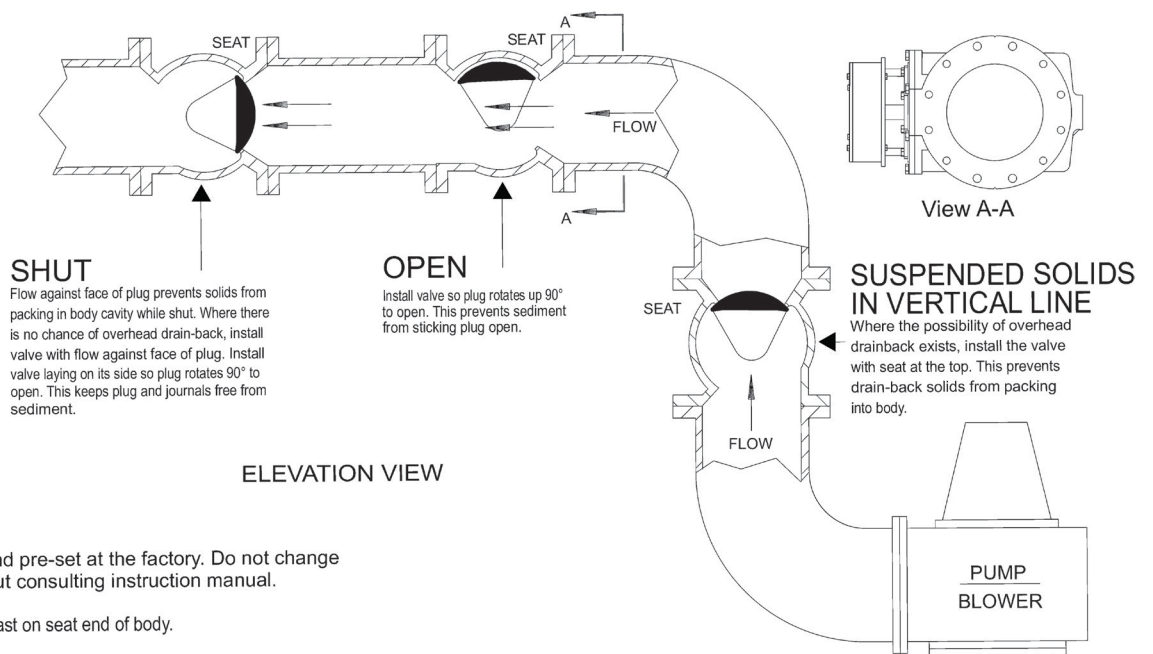

NOTE - 1. Units are tested and pre-set at the factory. Do not change adjustments without consulting instruction manual.

2. The word "SEAT" is cast on seat end of body.

Ordering

To order, simply complete the valve order code from information shown. An ordering example is shown for your reference.

Valve Style

Give valve style code as follows:

PEF = 100% Port Eccentric Plug

Valve Size

Give valve size code as follows:

3 = 3" (80mm)	14 = 14" (350mm)
4 = 4" (100mm)	16 = 16" (400mm)
5 = 5" (125mm)	18 = 18" (450mm)
6 = 6" (150mm)	20 = 20" (500mm)
8 = 8" (200mm)	24 = 24" (600mm)
10 = 10" (250mm)	30 = 30" (750mm)
12 = 12" (300mm)	36 = 36" (900mm)

End Connection

Give end connection code as follows:

F1 = Flanged, ANSI Class 125/150
 F110 = Flanged, ANSI Class 150, DIN 10 or B54504/10
 F116 = Flanged, ANSI Class 150, DIN 16 or B54504/16
 F1D = Flanged, ANSI Class 150, BS Table D
 F1E = Flanged, ANSI Class 150, BS Table E
 F1J1 = Flanged, ANSI Class 150, JIS Drilling
 MJ = Mechanical Joint (Not Available on 5")

Body Material

Give body material code as follows:

CI = Cast Iron
 DI = Ductile Iron

Packing

Give packing code as follows:

NBR = Acrylonitrile-Butadiene V-Type Multiple V-Ring
 -20 to 250°F (-29 to 121°C)
 T = PTFE -20 to 450°F (-29 to 232°C)

Plug Facing

Give plug facing code as follows:

Standard facings:

CR = Chloroprene (RS 16/17) -20 to 180°F (-29 to 83°C)
 CIIR = Chloro-Isobutene Isoprene (RS55/56)
 -20 to 250°F (-29 to 121°C)
 NBR = Acrylonitrile-Butadiene (RS24/25) -20 to 180°F (-29 to 83°C)

Options

ALS = Valves conform to H.R. 3547 Consolidated Appropriations Act, 2014 Section 436
 BAA = Buy American Act
 CMC = Certificate of Material Conformance
 DST = Dry Seat Test
 DTR = DeZURIK Standard Certified Production Hydrostatic Shell & Seat Test Report
 PD = 1/4" Pipe Tap Downstream
 PU = 1/4" Pipe Tap Upstream
 PDU = 1/4" Pipe Tap Downstream & Upstream
 ST3 = Pennsylvania Steel Procurement Act
 GL = Glass Lining 4-24" (Ductile Iron Body Material with CR & NBR plug facings only)
 GR = Grease Fittings in Body & Bonnet (Flanged Valves only) not available with ENK extension
 TB = Certified Seat Leak Test Both Directions per AWWA C517
 TD = Certified Seat Leak Test Direct Pressure per AWWA C517
 TR = Certified Seat Leak Test Reverse Pressure per AWWA C517

Note: The limiting factor in valve selection is the lowest temperature limit of the packing or seat.

Ordering Example:

PEF,8,F1,CI,NBR,CR*GS-6A-HD8

Manual Actuators

Pressure Ratings

Direct shutoff pressure differentials for nut or lever actuated valves must not exceed the limits shown below. If valves must seal higher pressure, use gear actuators. Gear or powered actuators are recommended on 6" (150mm) and larger valves as well as on applications where pipeline velocities are high and where sudden valve closure may cause water hammer. Valves for gas service must be furnished with gear or cylinder actuator.

2" Square Nut (NT)

Furnished as standard on 3-8" (80-200mm) valves. Must be ordered to use VB, ENLVA, EF, LVA, CHA, LVF, and WRT. To order, add code NT to basic valve code.

Ordering Example:
PEF,4,F1,CI,NBR,CR*NT



Nut Actuators, Direct Pressure

Valve Size	Max. Shutoff Pressure Differential psi/kPa	
	40 Lb Lever Pull	80 Lb Lever Pull
3" 75mm	125 850	175 1200
4" 100mm	25 170	125 800
5" 125mm	25 170	50 340
6" 150mm	25 170	50 340
8" 200mm	N/A	**75 500

** Exceeds AWWA C517 Shaft Torque Limits

Nut Actuators, Reverse Pressure

Valve Size	Max. Shutoff Pressure Differential psi/kPa	
	40 Lb Lever Pull	80 Lb Lever Pull
3" 75mm	25 170	175 1200
4" 100mm	N/A	50 340
5" 125mm	N/A	25 170
6" 150mm	N/A	25 170
8" 200mm	N/A	**25 170

Manual Actuator Accessories

Adjustable Memory Stop

All 3–8" (80-200mm) lever actuated valves are furnished with an adjustable, open position memory stop as standard. Adjustment of the stop to the desired open position allows the valve to be closed and reopened to the same throttling position.

Lever (LVA)

For use with NT actuators on 3-8" (80-200mm) valves. Lever must be ordered separately.

Order Code	Size
ACC*LVA-3	3" (80mm)
ACC*LVA-4	4" (100mm)
ACC*LVA-5	5" (125mm)
ACC*LVA-6	6" (150mm)
ACC*LVA-8	8" (200mm)

Ordering Example:
ACC*LVA-4

Stainless Steel Bolting

Specify bolting requirements by giving code SB18 for 18-8 Stainless Steel or SB16 for 316 Stainless Steel.

Ordering Example:
PEF,8,FI,CI,NBR,CR*GS-6A-HD8,SB16

Chain Handle (CHA)

For use on 3-8" (80-200mm) valves with NT Nut. Chain Handle must be ordered separately by giving code ACC*CHA followed by a dash and valve size.

Order Code	Size
ACC*CHA-3	3" (80mm)
ACC*CHA-4	4" (100mm)
ACC*CHA-5	5" (125mm)
ACC*CHA-6	6" (150mm)
ACC*CHA-8	8" (200mm)

Ordering Example:
ACC*CHA-4

Chain (CN) for Chain Handle or Chainwheel Actuator

Order as a separate item by giving code per chart. Specify number of feet required and number of pieces.

Order Code	Description
ACC*CN102	Standard 3/16" Coil
ACC*CN103	Galvanized 3/16" Coil
ACC*CN104	316 Stainless Steel 3/16" Coil

Ordering Example:
ACC*CN102
Chain 1 piece 10 feet long.

Manual Gear Actuators

The G-Series and MG manual actuators construction are totally enclosed and sealed, protecting moving parts from damage or corrosion. Continual lubrication is not required for operational ease. Heavy duty, corrosion-resistant actuator bearings provide lasting, easy valve operation and overall reliability. Rugged actuator castings, gears and shafts also add to reliability by assuring permanent alignment of moving parts for smooth operation.

To order, add the appropriate actuator code from the sizing tables to the valve order code. Order codes in charts are for weatherproof nut actuator. For Buriable Actuator, change GS to GB or MG to MGB. Buriable actuators have ductile iron gear sector, completely enclosed mounting bracket and actuator cover.



Manual Gear with Nut

Direct Pressure, Resilient Plug, Metal Seat

Valve Size	Order Code	Max. Shutoff Pressure Differential psi/kPa
3-12" 80-300mm	GS-6A-N	175
		1210
14 & 16" 350 & 400mm	GS-12A-N	150
		1030
18" 450mm	GS-12A-N	125
	MG-WR1L-N	860
20" 500mm	GS-12A-N	150
	MG-WR1L-N	1030
24" 600mm	MG-WR1L-N	75
	MG-WR3L-N	520
30" 750mm	MG-WR3L-N	150
	MG-WR4L-N	1030
36" 900mm	MG-WR5L-N	150
		1030

Reverse Pressure, Resilient Plug, Metal Seat

Valve Size	Order Code	Max. Shutoff Pressure Differential psi/kPa
3-12" 80-300mm	GS-6A-N	175
		1210
14 & 16" 350 & 400mm	GS-12A-N	150
		1030
18" 450mm	GS-12A-N	75
	MG-WR1L-N	520
20" 500mm	MG-WR1L-N	150
		1030
24" 600mm	GS-12A-N	50
	MG-WR1L-N	340
30" 750mm	MG-WR1L-N	100
	MG-WR3L-N	690
36" 900mm	MG-WR3L-N	150
		1030
18" 450mm	MG-WR1L-N	25
	MG-WR3L-N	170
24" 600mm	MG-WR3L-N	125
	MG-WR4L-N	860
30" 750mm	MG-WR4L-N	150
		1030
36" 900mm	MG-WR3L-N	75
	MG-WR4L-N	520
18" 450mm	MG-WR4L-N	150
		1030
24" 600mm	MG-WR4L-N	50
	MG-WR5L-N	340
30" 750mm	MG-WR5L-N	150
		1030

Handwheel Actuators

Direct Pressure, Resilient Plug, Metal Seat

Valve Size	Order Code	Max. Shutoff Pressure Differential psi/kPa
3-8" 80-200mm	GS-6A-HD8**	175
		1210
10" 250mm	GS-6A-HD8**	75
	GS-6A-HD12	125
	GS-12A-HD12	860
12" 300mm	GS-12A-HD12	175
	GS-6A-HD12	1210
	GS-12A-HD12	75
12" 300mm	GS-6A-HD12	520
	GS-12A-HD12	125
	GS-12A-HD16	860
14" 350mm	GS-12A-HD16	175
	GS-12A-HD12	1210
	GS-12A-HD16	50
14" 350mm	GS-12A-HD12	340
	GS-12A-HD16	100
	GS-12A-HD20	690
16" 400mm	GS-12A-HD20	150
	GS-12A-HD16	1030
	GS-12A-HD16	50
16" 400mm	GS-12A-HD16	340
	GS-12A-HD20	75
	GS-12A-HD24*	520
18" 450mm	GS-12A-HD24*	150
	GS-12A-HD20	1030
	GS-12A-HD20	25
18" 450mm	GS-12A-HD20	170
	GS-12A-HD24*	50
	GS-12A-HD30*	340
20" 500mm	MG-WR1L-HD24	125
	GS-12A-HD30*	860
	MG-WR1L-HD24	150
20" 500mm	MG-WR1L-HD24	1030
	GS-12A-HD24*	25
	GS-12A-HD30*	170
24" 600mm	MG-WR1L-HD32*	75
	MG-WR1L-HD30*	520
	MG-WR3L-HD32*	150
24" 600mm	MG-WR3L-HD32*	1030
	MG-WR1L-HD30*	75
	MG-WR4L-HD36*	520
30" 750mm	MG-WR4L-HD36*	150
	MG-WR5L-HD32	1030
	MG-WR5L-HD32	150
36" 900mm	MG-WR5L-HD32	1030

* Mounting positions 90 and 270° not available.

** If FSDIR or FSDIU is required use HD12 in place of HD8.

ORDERING EXAMPLE:

PEF,8,F1,C1,NBR,CR*GS-6A-HD8

Reverse Pressure, Resilient Plug, Metal Seat

Valve Size	Order Code	Max. Shutoff Pressure Differential psi/kPa
3-6" 80-150mm	GS-6A-HD8**	175
		1210
8" 200mm	GS-6A-HD8**	125
	GS-6A-HD12	860
10" 250mm	GS-6A-HD12	175
	GS-6A-HD12	1210
	GS-12A-HD12	75
10" 250mm	GS-12A-HD12	520
	GS-12A-HD12	150
	GS-12A-HD16	1030
12" 300mm	GS-12A-HD16	175
	GS-12A-HD12	1210
	GS-12A-HD16	25
12" 300mm	GS-6A-HD12	170
	GS-12A-HD12	75
	GS-12A-HD16	520
14" 350mm	GS-12A-HD16	150
	GS-12A-HD20	1030
	GS-12A-HD20	175
14" 350mm	GS-12A-HD12	1210
	GS-12A-HD12	25
	GS-12A-HD16	170
16" 400mm	GS-12A-HD16	75
	GS-12A-HD20	520
	GS-12A-HD24*	100
16" 400mm	GS-12A-HD24*	690
	GS-12A-HD24*	150
	GS-12A-HD20	1030
18" 450mm	GS-12A-HD16	25
	GS-12A-HD20	170
	GS-12A-HD24*	50
18" 450mm	GS-12A-HD24*	340
	GS-12A-HD20	125
	GS-12A-HD24*	860
20" 500mm	MG-WR1L-HD24	150
	MG-WR1L-HD24	1030
	GS-12A-HD20	25
20" 500mm	GS-12A-HD20	170
	GS-12A-HD24*	50
	GS-12A-HD30*	340
24" 600mm	GS-12A-HD30*	75
	MG-WR1L-HD32*	520
	MG-WR1L-HD32*	150
24" 600mm	MG-WR1L-HD32*	1030
	GS-12A-HD30*	50
	MG-WR1L-HD32*	340
20" 500mm	MG-WR3L-HD32*	150
	MG-WR3L-HD32*	1030
	GS-12A-HD30*	50
24" 600mm	MG-WR1L-HD30*	340
	MG-WR1L-HD30*	25
	MG-WR3L-HD36*	170
30" 750mm	MG-WR3L-HD36*	125
	MG-WR4L-HD32*	860
	MG-WR4L-HD32*	150
30" 750mm	MG-WR4L-HD32*	1030
	MG-WR3L-HD36*	75
	MG-WR4L-HD36*	520
36" 900mm	MG-WR4L-HD36*	150
	MG-WR4L-HD32*	1030
	MG-WR4L-HD32*	50
36" 900mm	MG-WR5L-HD32	340
	MG-WR5L-HD32	150
	MG-WR5L-HD32	1030

Chainwheel Actuators

Direct Pressure, Resilient Plug, Metal Seat

Valve Size	Order Code	Max. Shutoff Pressure Differential psi/kPa
3-8" 80-200mm	GS-6A-CW8	175
		1210
10" 250mm	GS-6A-CW8	75
	GS-6A-CW12	125
	GS-12A-CW12	860
12" 300mm	GS-12A-CW12	175
	GS-12A-CW12	1210
	GS-12A-CW20	175
14" 350mm	GS-12A-CW12	75
	GS-12A-CW20	520
16" 400mm	GS-12A-CW20	125
	GS-12A-CW24*	860
18" 450mm	GS-12A-CW20	150
	GS-12A-CW24*	1030
	GS-12A-CW30*	25
	MG-WR1L-CW24	170
20" 500mm	GS-12A-CW24*	50
	GS-12A-CW30*	340
	MG-WR1L-CW30	125
24" 600mm	MG-WR1L-CW30*	860
	MG-WR3L-CW30*	150
30" 750mm	MG-WR3L-CW30*	1030
	MG-WR4L-CW30*	75
	MG-WR5L-CW30*	520
36" 900mm	MG-WR4L-CW30*	125
	MG-WR5L-CW30*	860

* Mounting positions 90° and 270° not available.

ORDERING EXAMPLE:

PEF,36,F1,C1,NBR,CR*MG-WR5L-CW30

Reverse Pressure, Resilient Plug, Metal Seat

Valve Size	Order Code	Max. Shutoff Pressure Differential psi/kPa
3-6" 80-150mm	GS-6A-CW8	175
		1210
8" 200mm	GS-6A-CW8	125
	GS-6A-CW12	860
10" 250mm	GS-12A-CW12	175
	GS-12A-CW12	1210
	GS-12A-CW20	175
12" 300mm	GS-6A-CW12	75
	GS-12A-CW12	520
	GS-12A-CW20	125
14" 350mm	GS-12A-CW12	1030
	GS-12A-CW12	175
	GS-12A-CW20	1210
16" 400mm	GS-12A-CW12	25
	GS-12A-CW24*	170
	MG-WR1L-CW20	50
18" 450mm	GS-12A-CW20	340
	GS-12A-CW24*	125
	MG-WR1L-CW20	860
20" 500mm	GS-12A-CW20	150
	GS-12A-CW24*	1030
	MG-WR1L-CW30*	25
24" 600mm	GS-12A-CW20	170
	GS-12A-CW24*	50
	MG-WR1L-CW30*	340
30" 750mm	GS-12A-CW30*	75
	MG-WR1L-CW30*	520
	MG-WR3L-CW30*	150
36" 900mm	MG-WR1L-CW30*	1030
	MG-WR3L-CW30*	50
	MG-WR4L-CW30*	340

Manual Actuator Extensions

EFA Extension for Nut Actuated Valves

For use on 3–8" (80–200mm) valves. Includes extension pipe, bearing plate and couplings. Valves for use with EFA extensions must be ordered with NT actuators. Order Extension Assembly as a separate item. Specify length from centerline of valve to bottom of bearing plate. When ordering for use with FS101 Floor Stand, give dimension from centerline of valve to base of floor stand.

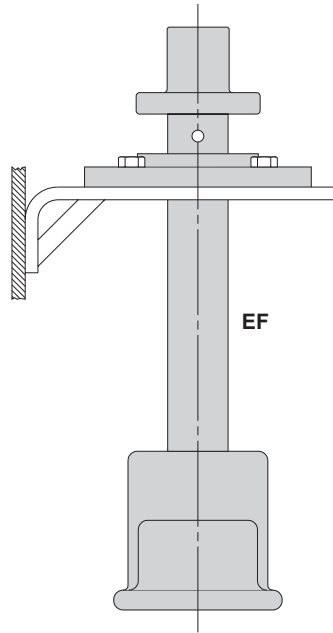

Ordering Example:

ACC*EF-4

Centerline of valve to bottom of bearing plate 110" (2795mm).

FSDIR and FSDIU Floor Stand for Gear Actuated Valves

For use on 3–36" (80–900mm) handwheel actuated valves. Includes floor stand, couplings, extension rod, and handwheel mounted on floor stand, with dial position indicator. Order floor stand by adding FSDIR or FSDIU to the valve actuator code.

Ordering Example:

PEF,6,F1,NBR,CR*,GS-6A-HD12,FSDIR

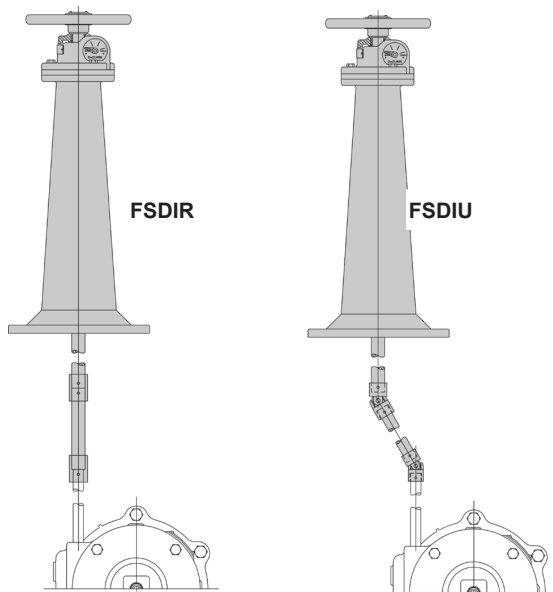

Centerline of valve to base of floor stand 90" (2400mm).

FB Floor Box for Nut Actuated Valves

Includes floor box and cover only. Can be used with valves having operating nut mounted on the valve or extended with top of nut 2" (50mm) from top of floor box. All valves for use with floor boxes are Tee Wrench actuated (order separately). Order extended operating nuts (ENLVA) separately. Floor box requires NT actuators (order separately). Order floor boxes separately. Specify ACC*FB and depth of floor box in 1" (25mm) increments from 6–18" (150–455mm). Standard depth is 6" (150mm).

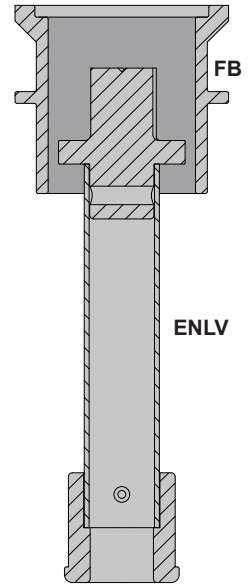

Ordering Example:

ACC*FB6

ENLVA Extended Nut for Nut Actuated Valves

For use on 3–8" (80–200mm) nut actuated valves. Includes operating nut, couplings and pipe. Valves for use with ENLVA Extended Nut must be ordered with NT actuators. All valves for use with ENLVA are Tee Wrench activated (order separately). Order as a separate item by giving ACC*ENLVA followed by a dash and valve size. Give required length from centerline of valve to top of nut. Note dimensions in table.

Valve Size	Minimum Dimension C/L of Valve to Top of Nut
3" 80mm	16.19" 411mm
4" 100mm	16.69" 424mm
5–6" 125–150mm	19.12" 486mm
8" 200mm	22.38" 570mm

Ordering Example:

ACC*ENLVA-8

Centerline of valve to top of valve nut 126" (3200mm).

FS101 Floor Stand for Nut Actuated Valves

For use on 3–8" (80–200mm) nut actuated valves. Includes floor stand only. For extension pipe and fittings, order EFA Extension Assembly. Lever actuated valves for use with EFA Extension and FS101 Floor Stand must be ordered NT actuators. Order floor stands as a separate item.

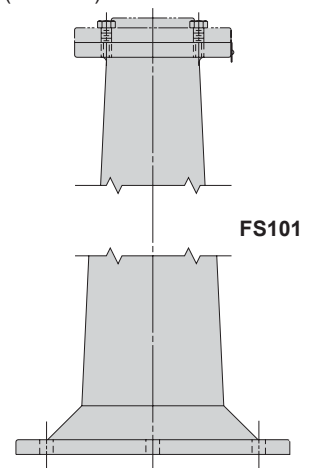

Ordering Example:

ACC*FS101

DeZURIK.com

Manual Actuator Extensions

ENGS Extended 2" (50mm) Nut for Gear Actuated Valves

The ENGS is for use on 3–36" (80–900mm) PEF Eccentric Plug Valves with G-Series and MG Handwheel Manual Actuator. Includes couplings, extension rod and 2" (50mm) square nut. If used with valve box, top of nut must be 6" (150mm) below grade. If used with floor box, top of nut must be 2" (50mm) below floor surface. Handwheels are not furnished on actuators ordered with ENGS. Order by adding ENGS to the valve actuator code. Specify required length from centerline of valve to top of nut as second line information.

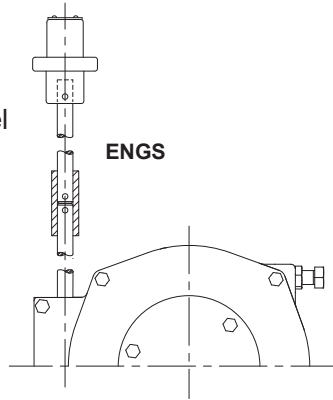

Ordering Example:

PEF,6,F1,CI,NBR,CR*GB-6A-N,ENGS
Centerline of valve to top of nut 72" (1830mm).

WRT Tee Wrench

For use on 3–8" (80–200mm) nut or gear actuated valves with 2" (50mm) nut. Valves for Tee Wrench operation must be ordered with NT actuator. Contact factory to order Tee Wrenches.

Cylinder Actuators

G-Series cylinder actuators feature a rack and pinion design for larger size rotary valves where constant torque capability throughout the stroke is required. They are engineered for high flow, high cycle applications. The G-Series line of actuators provides long service life and features a rugged, heavy cast gear sector. The cast iron actuator housing is sealed to prevent the entry of dirt, moisture and corrosive contaminants. The G-Series actuator also features adjustable position stops, rugged cylinder construction and corrosion-resistant bearings.

ENK Neck Extension for G-Series Actuators

Valves for buried or submerged service can be furnished with handwheel or cylinder actuators extended above the ground. Furnish service information for recommendations.

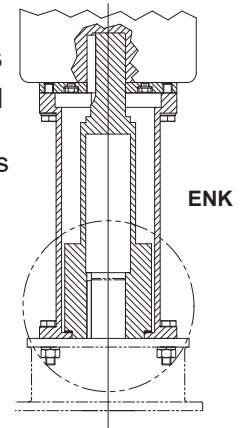

VB Valve Box for Nut Actuated Valves

Valve boxes for use on 3–8" (80–200mm) valves require a nut (NT) or extended nut (ENLV) type actuator. Valve boxes for use on 3–36" (80–900mm) valves with a gear actuator (GB) require a 2" (50mm) Nut (N) or extended 2" (50mm) Nut (ENGS) actuator. Extended nut must be 6" (150mm) from the top of the valve box. Contact factory to order.

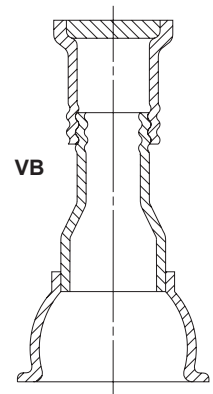

Double-Acting Cylinder Actuators

To order double-acting cylinder actuators for PEF Eccentric Plug Valves, add the order code from the proper table to the valve order code. Actuators can be mounted at 90 degree increments clockwise from standard. Specify mounting positions other than standard as second line information. When using hydraulic supply media, specify type.

Double-Acting Cylinder Actuators

**Direct Pressure, Resilient Plug, Metal Seat
50 psi (340 kPa) Air Supply**

Valve Size	Actuator Code	Maximum Shutoff
3 & 4" 80 & 100mm	GS-6A-PC4*	175 1210
	GS-6A-PC6	175 1210
5 & 6" 125 & 150mm	GS-6A-PC6	125 860
	GS-6A-PC8	175 1210
8" 200mm	GS-6A-PC6	50 340
	GS-6A-PC8	150 1030
	GS-12A-PC6	175 1210
10" 250mm	GS-6A-PC8	150 1030
	GS-12A-PC6	100 690
	GS-12A-PC8	175 1210
12" 300mm	GS-6A-PC8	25 170
	GS-12A-PC8	100 690
	GS-12A-PC10	175 1210
14" 350mm	GS-12A-PC8	50 340
	GS-12A-PC10	125 860
	O/A	150 1030
16" 400mm	GS-12A-PC10	50 340
	O/A	150 1030
18" 450mm	GS-12A-PC10	25 170
	O/A	150 1030
20-36" 500-900mm	O/A	150 1030

* PC4 Cylinder not recommended with positioner

**Reverse Pressure, Resilient Plug, Metal Seat
50 psi (340 kPa) Air Supply**

Valve Size	Actuator Code	Maximum Shutoff
3" 80mm	C4*	175 1210
	GS-6A-PC6*	175 1210
4" 100mm	GS-6A-PC4*	100 690
	GS-6A-PC6	175 1210
5 & 6" 125 & 150mm	GS-6A-PC6	100 690
	GS-6A-PC8	175 1210
8" 200mm	GS-6A-PC6	25 170
	GS-6A-PC8	100 690
	GS-12A-PC6	125 860
	GS-12A-PC8	175 1210
10" 250mm	GS-6A-PC8	25 170
	GS-12A-PC6	50 340
	GS-12A-PC8	125 860
	GS-12A-PC10	175 1210
12" 300mm	GS-12A-PC8	75 520
	GS-12A-PC10	150 1030
14" 350mm	GS-12A-PC8	25 170
	GS-12A-PC10	75 520
	O/A	150 1030
16" 400mm	GS-12A-PC10	25 170
	O/A	150 1030
18" 450mm	O/A	150 1030
	O/A	150 1030
20-36" 500-900mm	O/A	150 1030

* PC4 Cylinder not recommended with positioner

Double-Acting Cylinder Actuators

**Direct Pressure, Resilient Plug, Metal Seat
80 psi (550 kPa) Air Supply**

Valve Size	Actuator Code	Maximum Shutoff
3 & 4" 80 & 100mm	GS-6A-PC4*	175 1210
	GS-6A-PC6	175 1210
5 & 6" 125 & 150mm	GS-6A-PC4*	75 250
	GS-6A-PC6	175 1210
8" 200mm	GS-6A-PC6	125 860
	GS-6A-PC8	175 1210
10" 250mm	GS-6A-PC6	50 340
	GS-6A-PC8	125 860
	GS-12A-PC6	150 1030
	GS-12A-PC8	175 210
12" 300mm	GS-6A-PC6	25 170
	GS-6A-PC8	75 520
	GS-12A-PC6	100 690
	GS-12A-PC8	175 1210
14" 350mm	GS-12A-PC8	125 860
	GS-12A-PC10	150 1030
16" 400mm	GS-12A-PC8	50 340
	GS-12A-PC10	125 860
	O/A	150 1030
18" 450mm	GS-12A-PC8	25 170
	GS-12A-PC10	50 340
	O/A	150 1030
20" 500mm	GS-12A-PC10	25 170
	O/A	150 1030
24-36" 600-900mm	O/A	150 1030

* PC4 Cylinder not recommended with positioner

**Reverse Pressure, Resilient Plug, Metal Seat
80 psi (550 kPa) Air Supply**

Valve Size	Actuator Code	Maximum Shutoff
3 & 4" 80 & 100mm	GS-6A-PC4*	175 1210
	GS-6A-PC6	175 1210
5 & 6" 125 & 150mm	GS-6A-PC4*	25 170
	GS-6A-PC6	175 1210
8" 200mm	GS-6A-PC6	75 520
	GS-6A-PC8	175 1210
10" 250mm	GS-6A-PC6	25 170
	GS-6A-PC8	75 520
	GS-12A-PC6	125 860
	GS-12A-PC8	175 1210
12" 300mm	GS-6A-PC8	25 170
	GS-12A-PC6	50 340
	GS-12A-PC8	150 1030
	GS-12A-PC10	175 1210
14" 350mm	GS-12A-PC8	75 520
	GS-12A-PC10	150 1030
16" 400mm	GS-12A-PC8	25 170
	GS-12A-PC10	100 690
	O/A	150 1030
18" 450mm	GS-12A-PC10	25 170
	O/A	150 1030
20" 500mm	GS-12A-PC10	25 170
	O/A	150 1030
24-36" 600-900mm	O/A	150 1030

* PC4 Cylinder not recommended with positioner

Spring-Return Cylinder Actuators

To order spring-return cylinder actuators, add the order code from the proper chart to the basic valve order code. Specify actuator action as second line information.

Actuators can be mounted at 90 degree increments clockwise from standard. Specify mounting positions other than standard as second line information.

Resilient Plug, Metal Seat, Direct Pressure or Reverse Pressure Less Than 25 psi (170 kPa)

Spring-To-Close (Air-To-Open) Air Supply, 50 psi (340 kPa)

Valve Size	Order Code	Maximum Shutoff Pressure Differential
3 & 4" 80 & 100mm	GS-6A-SC8	125 860
5 & 6" 125 & 150mm	GS-6A-SC8	25 170
8" 200mm	GS-12A-SC10	50 340

Spring-To-Open (Air-To-Close) Air Supply, 50 psi (340 kPa)

Valve Size	Order Code	Maximum Shutoff Pressure Differential
3 & 4" 80 & 100mm	GS-6A-SC6-A	175 1210
5 & 6" 125 & 150mm	GS-6A-SC6-A	25 170
	GS-6A-SC8-A	100 690
8" 200mm	GS-12A-SC10-A	175 1210
10" 250mm	GS-12A-SC10-A	125 860
12" 300mm	GS-12A-SC10-A	75 520

Note: Contact Application Engineering for actuator sizing when reverse pressures are greater than 25 psi (170 kPa). Furnish service conditions.

Ordering Example:

PEF,6,F1,CI,NBR,CR*GS-6A-SC8-A

Accessories – Cylinder Actuators

Positioners

For use on all cylinder actuators. Refer to DeZURIK's website for more information.

3- & 4-Way Solenoid Valve (3V & 4V)

For use on cylinder actuators. To order solenoids, refer to bulletin 84.00-1.

4-Way Control Valve (CV)

For use on double-acting cylinder actuators. Order as a separate item by giving ACC* followed by appropriate 3-digit code from the table below. To order as part of a complete valve/actuator assembly, enter code from table below to the valve/actuator order code.

Pneumatic Actuators

Valve Size	NPT Size	Order Code
All Sizes	.25" 6.4mm	CV201

Hydraulic Actuators

Valve Size	NPT Size	Order Code
3-8" 80-200mm	.375" 9.5mm	CV202
10-36" 250-900mm	.5" 13mm	CV203

Ordering Example:

ACC*CV201 (separate item)

Ordering Example:

PEF,6,F1,CI,NBR,CR*GS-6A-PC6,CV201

Position Indicating Switches (SEH)

For use on G-Series Actuators. To order switches, refer to bulletin 83.00-1.

Air Filter Regulator (AFR2)

For use on all pneumatic actuators. To order, refer to bulletin 83.00-2.

Filter/Strainer (FH/FP)

Filter for pneumatic actuators, strainer for hydraulic actuators. Order as a separate item per table below (not mounted).

Description	Order Code
Pneumatic Filter	ACC*PCFP
Hydraulic Strainer	ACC*PCFH

Ordering Example:

ACC*PCFP

Electric Motors

DeZURIK offers a variety of electric motor actuators on PEF Eccentric Plug valves. When ordering, please specify valve function, installation location, line fluid, maximum fluid temperature, pipe connection, line size, normal and maximum working pressure, normal and maximum wide open valve flow, and flow range desired if throttling or modulating control.

Dimensions

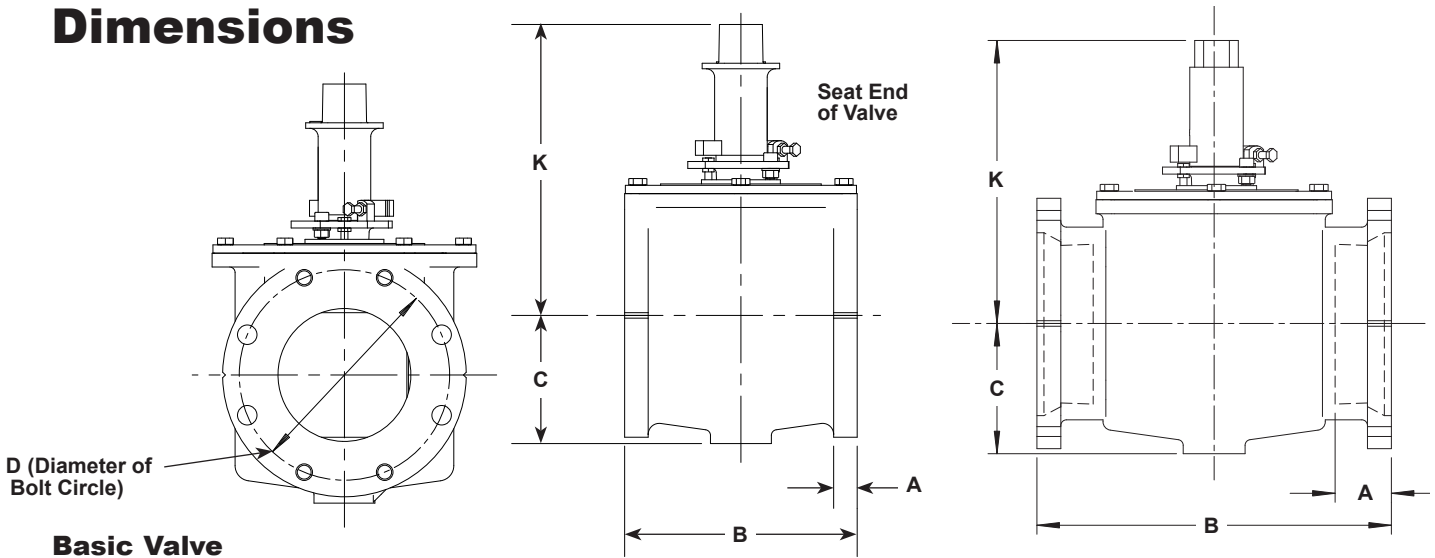

Basic Valve

Valve Size	A		B		C	D Flanged	
	Flanged	Mechanical Joint	Flanged	Mechanical Joint			
3" 80mm	0.83 21	2.50 63	8.00 203	11.50 292	3.56 90	6.00 152	
4" 100mm	1.02 26	2.50 63	9.00 229	14.25 362	4.43 113	7.50 191	
5 & 6" 125 & 150mm	1.04 26	2.50 63	10.50 267	15.75 400	5.79 147	5" (125mm)	
						8.50 216	6" (150mm)
						9.50 241	
8" 200mm	1.23 31	2.50 63	11.50 292	17.38 441	7.65 194	11.75 298	
10" 250mm	1.30 33	2.50 63	13.00 330	19.38 492	9.19 233	14.25 362	
12" 300mm	1.36 35	2.50 63	14.00 355	20.75 527	11.53 293	17.00 432	
14" 350mm	1.50 38	3.50 89	17.00 431	24.50 622	12.06 306	18.75 476	
16" 400mm	1.55 39	3.50 89	17.75 450	27.25 692	14.13 359	21.25 540	
18" 450mm	1.68 43	3.50 89	21.50 546	29.25 743	15.57 395	22.75 578	
20" 500mm	1.76 45	3.50 89	23.50 596	31.00 787	16.81 427	25.00 635	
24" 600mm	2.06 52	3.50 89	42.00 1067	42.00 1067	19.31 490	29.50 749	
30" 750mm	2.53 64	4.00 102	51.00 1295	51.00 1524	21.75 552	36.00 914	
36" 900mm	2.78 71	4.00 102	60.00 1524	60.00 1524	26.38 670	42.75 1086	

Inch
Millimeter

Nut Actuated Valves (NT) 3-8" (80-200mm)

Valve Size	K
3" 80mm	9.38 203
4" 100mm	9.88 219
5 & 6" 125 & 150mm	12.31 313
8" 200mm	15.56 395

Inch
Millimeter

Note: All dimensions are subject to change without notice.
Request certified drawings for use in preparing piping layout.

Dimensions

Nut

Valve Size	Actuator Code	K	L	S
3" 80mm	GS-6A-N	8.00 203	10.69 272	15.25 387
4" 100mm	GS-6A-N	8.62 219	11.31 287	15.25 387
5 & 6" 125 & 150mm	GS-6A-N	9.75 248	12.44 316	15.25 387
8" 200mm	GS-6A-N	12.09 307	14.78 375	15.25 387
10" 250mm	GS-6A-N	13.50 343	16.19 411	15.25 387
	GS-12A-N	14.88 378	17.62 500	16.69 424
12" 300mm	GS-6A-N	15.56 395	18.25 464	15.25 387
	GS-12A-N	16.94 430	19.69 500	16.69 424
14" 350mm	GS-12A-N	18.25 464	21.00 533	19.69 500
16" 400mm	GS-12A-N	19.69 500	22.44 570	19.69 500
18" 450mm	GS-12A-N	20.94 532	23.69 602	19.69 500
	MG-WR1L-N	23.31 592	26.75 679	14.34 364
20" 500mm	GS-12A-N	22.75 578	25.50 648	19.69 500
	MG-WR1L-N	25.12 638	28.56 725	14.34 364
	MG-WR3L-N	25.31 643	28.75 730	14.38 365
24" 600mm	MG-WR1L-N	28.50 642	31.94 811	14.34 364
	MG-WR3L-N	28.50 642	31.94 811	14.38 365
	MG-WR4L-N	30.88 784	34.31 871	20.50 521
30" 750mm	MG-WR3L-N	30.94 786	34.38 873	14.38 365
	MG-WR4L-N	33.31 846	36.75 933	20.50 521
36" 900mm	MG-WR4L-N	37.81 960	41.25 1048	20.50 521
	MG-WR5L-N	40.63 1032	44.13 1121	22.22 564

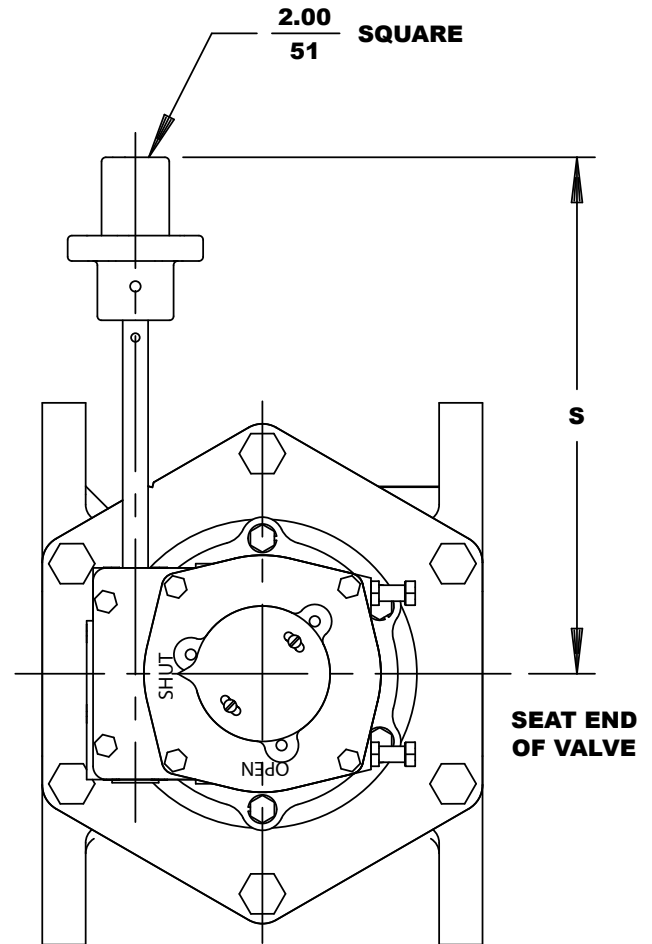

Dimensions

Handwheel Actuator

Valve Size	Actuator Code	K	L	R	S
3" 80mm	GS-6A-HD8	8.00 203	10.69 272	8.00 203	11.81 300
4" 100mm	GS-6A-HD8	8.62 219	11.31 287	8.00 203	11.81 300
5 & 6" 125 & 150mm	GS-6A-HD8	9.75 248	12.44 316	8.00 203	11.81 300
8" 200mm	GS-6A-HD8	12.09 307	14.78 375	8.00 203	11.81 300
	GS-6A-HD12	12.09 307	14.78 375	12.00 305	11.81 300
10" 250mm	GS-6A-HD8	13.50 343	16.19 411	8.00 203	11.81 300
	GS-6A-HD12	13.50 343	16.19 411	12.00 305	11.81 300
	GS-12A-HD12	14.88 378	17.62 500	12.00 305	15.12 384
	GS-12A-HD16	14.88 378	17.62 500	16.00 406	15.48 393
12" 300mm	GS-6A-HD12	15.56 395	18.25 464	12.00 305	11.81 300
	GS-12A-HD12	16.94 430	19.69 500	12.00 305	15.12 384
	GS-12A-HD16	16.94 430	19.69 500	16.00 406	15.48 393
	GS-12A-HD20	16.94 430	19.69 500	20.00 508	15.48 393
14" 350mm	GS-12A-HD12	18.25 464	21.00 533	12.00 305	18.12 460
	GS-12A-HD16	18.25 464	21.00 533	16.00 406	18.50 470
	GS-12A-HD20	18.25 464	21.00 533	20.00 508	18.50 470
	GS-12A-HD24	18.25 464	21.00 533	24.00 610	22.19 564
16" 400mm	GS-12A-HD16	19.69 500	22.44 570	16.00 406	18.50 470
	GS-12A-HD20	19.69 500	22.44 570	20.00 508	18.50 470
	GS-12A-HD24	19.69 500	22.44 570	24.00 610	22.19 564
	MG-WR1L-HD24	22.06 560	25.50 648	24.00 610	16.34 415
18" 450mm	GS-12A-HD20	20.94 532	23.69 602	20.00 508	18.50 470
	GS-12A-HD24	20.94 532	23.69 602	24.00 610	22.19 564
	GS-12A-HD30	20.94 532	23.69 602	30.00 762	23.69 602
	MG-WR1L-HD24	23.31 592	26.75 679	24.00 610	16.34 415
	MG-WR1L-HD32*	23.31 592	26.75 679	31.50 800	16.34 415
20" 500mm	GS-12A-HD24	22.75 578	25.50 648	24.00 610	22.19 564
	GS-12A-HD30	22.75 578	25.50 648	30.00 762	23.69 602
	MG-WR1L-HD32*	25.12 638	28.56 725	31.50 800	16.34 415
	MG-WR3L-HD32*	25.31 643	28.75 730	31.50 800	16.60 422
24" 600mm	MG-WR1L-HD30*	28.50 724	31.94 811	30.00 762	16.34 415
	MG-WR3L-HD32*	28.50 724	31.94 811	31.50 800	26.38 670
	MG-WR4L-HD32*	30.88 784	34.31 871	31.50 800	22.69 576
30" 750mm	MG-WR3L-HD32*	30.94 786	34.38 873	31.50 800	26.38 670
	MG-WR4L-HD36*	33.31 846	36.75 933	36.00 914	26.76 680
36" 900mm	MG-WR4L-HD32*	37.81 960	41.25 1048	31.50 800	22.69 576
	MG-WR5L-HD32	40.63 1032	44.21 1123	31.50 800	33.67 855

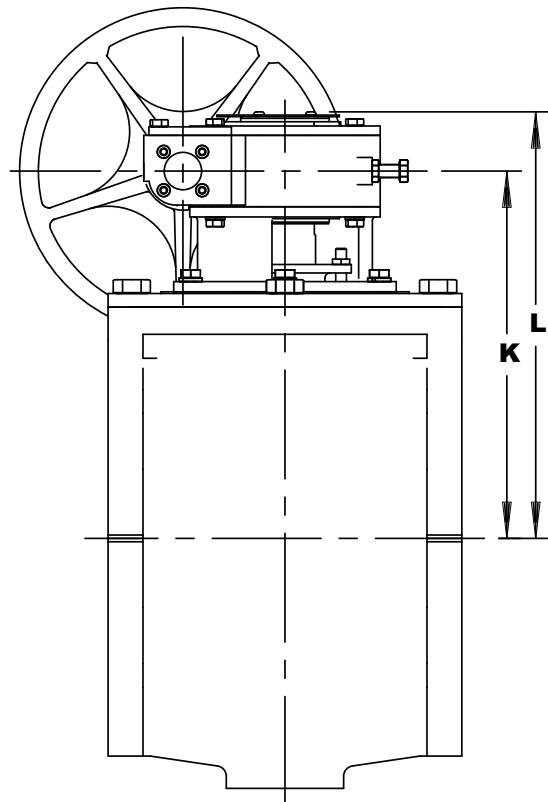
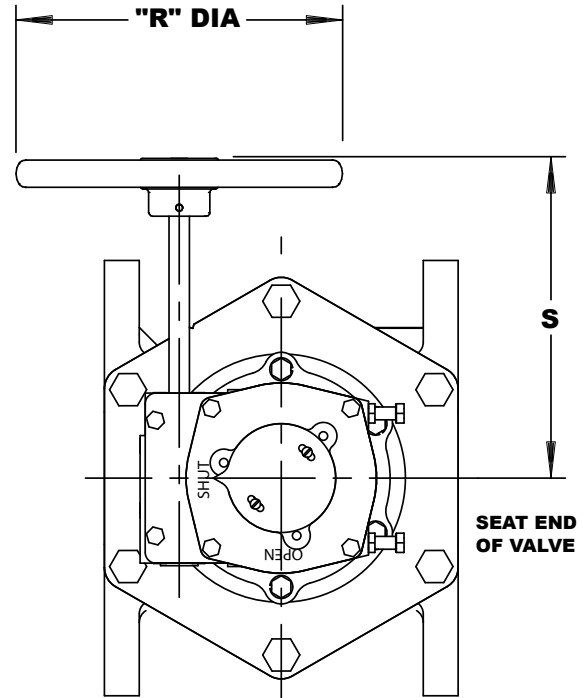

* Mounting positions 90° and 270° not available.

Dimensions

Chainwheel Actuator

Valve Size	Actuator Code	K	L	R	S
3" 80mm	GS-6A-CW8	8.00	10.69	8.00	11.75
		203	272	203	298
4" 100mm	GS-6A-CW8	8.62	11.31	8.00	11.75
		219	287	203	298
5 & 6" 125 & 150mm	GS-6A-CW8	9.75	12.44	8.00	11.75
		248	316	203	298
8" 200mm	GS-6A-CW8	12.09	14.78	8.00	11.75
	GS-6A-CW12	307	375	203	298
10" 250mm	GS-6A-CW8	13.50	16.19	8.00	11.75
	GS-6A-CW12	343	411	203	298
	GS-12A-CW12	13.50	16.19	12.00	11.75
	GS-12A-CW20	343	411	305	298
12" 300mm	GS-12A-CW12	14.88	17.62	12.00	14.38
	GS-12A-CW20	378	500	305	365
	GS-6A-CW12	15.56	18.25	12.00	11.75
	GS-12A-CW12	395	464	305	298
14" 350mm	GS-12A-CW12	16.94	19.69	12.00	14.38
	GS-12A-CW20	430	500	305	365
	GS-12A-CW24	16.94	19.69	20.00	14.38
16" 400mm	GS-12A-CW20	430	500	508	365
	GS-12A-CW24	18.25	21.00	12.00	17.38
	GS-12A-CW30	464	533	305	441
18" 450mm	GS-12A-CW20	18.25	21.00	20.00	17.38
	GS-12A-CW24	464	533	508	441
	GS-12A-CW30	18.25	21.00	24.00	17.38
20" 500mm	GS-12A-CW24	464	533	610	441
	GS-12A-CW30	19.69	22.44	20.00	17.38
	GS-12A-CW36	500	570	508	441
	MG-WR1L-CW30*	19.69	22.44	24.00	17.38
24" 600mm	MG-WR1L-CW20	560	648	510	543
	GS-12A-CW20	20.94	23.69	20.00	17.38
	GS-12A-CW24	532	602	508	441
	GS-12A-CW30	20.94	23.69	24.00	17.38
30" 750mm	GS-12A-CW24	532	602	610	441
	GS-12A-CW30	20.94	23.69	30.00	17.38
	MG-WR1L-CW24	592	679	762	543
	MG-WR1L-CW30*	23.31	26.75	24.44	21.38
36" 900mm	MG-WR1L-CW30*	23.31	26.75	29.75	21.38
	GS-12A-CW24	592	679	756	543
	GS-12A-CW30	22.75	25.50	24.00	17.38
	MG-WR1L-CW30*	578	648	610	441
36" 900mm	GS-12A-CW30	22.75	25.50	30.00	17.38
	MG-WR1L-CW30*	578	648	762	543
	MG-WR3L-CW30*	25.12	28.56	29.75	21.38
	MG-WR3L-CW30*	638	725	756	543
36" 900mm	MG-WR4L-CW30*	25.31	28.75	29.75	21.38
	MG-WR4L-CW30*	643	730	756	543
	MG-WR5L-CW30*	28.50	31.94	29.75	21.38
36" 900mm	MG-WR5L-CW30*	724	811	756	543
	MG-WR3L-CW30*	28.50	31.94	29.75	29.00
	MG-WR3L-CW30*	724	811	756	737
36" 900mm	MG-WR4L-CW30*	30.86	34.31	29.75	34.88
	MG-WR4L-CW30*	784	871	756	886
	MG-WR5L-CW30*	30.44	33.88	29.75	29.00
36" 900mm	MG-WR5L-CW30*	773	861	756	737
	MG-WR4L-CW30*	33.31	36.75	29.75	34.88
	MG-WR4L-CW30*	846	933	756	886
36" 900mm	MG-WR5L-CW30*	36.12	39.68	29.75	33.66
	MG-WR5L-CW30*	917	1008	756	855
36" 900mm	MG-WR5L-CW30*	40.65	44.21	29.75	33.66
36" 900mm	MG-WR5L-CW30*	1033	1123	756	855

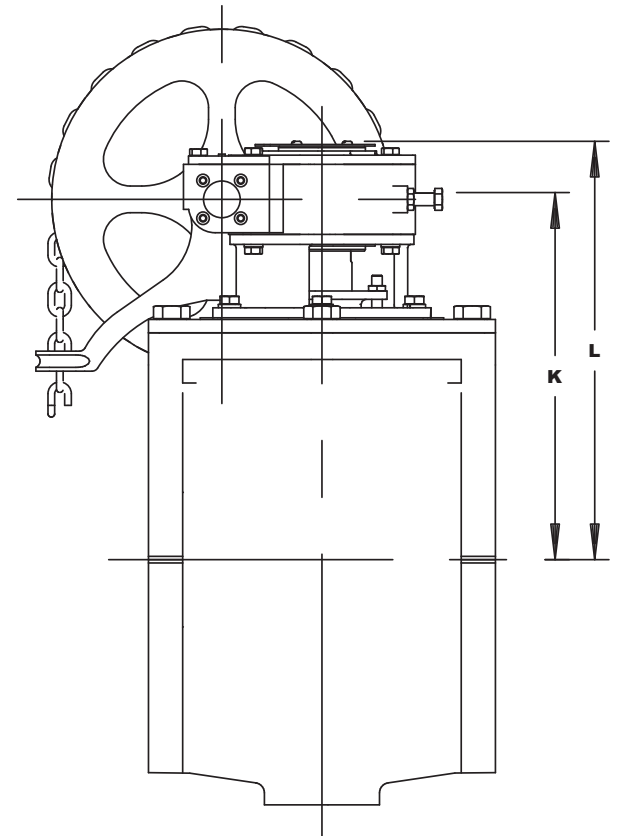
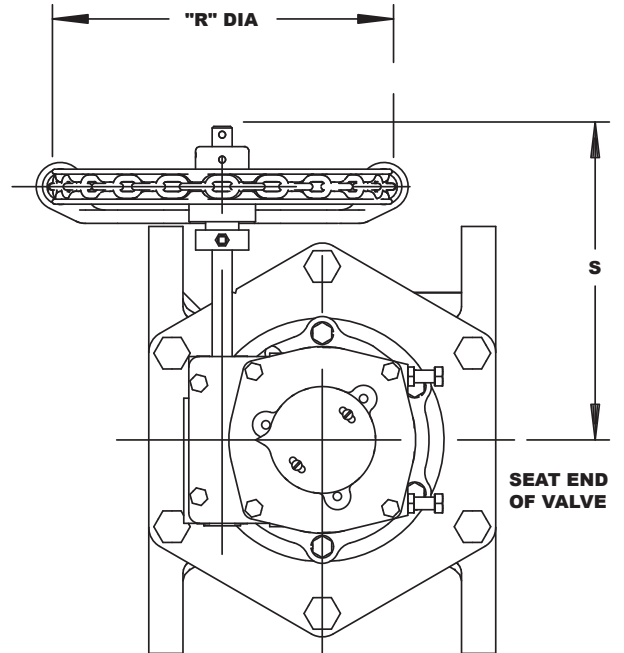

* Mounting positions 90° and 270° not available.

Dimensions

Double-Acting Cylinder Actuated Valves

Valve Size	Actuator Code	K	L	M	N	R (NPT)	P
3" 80mm	GS-6A-PC4	8.00 203	10.88 276	18.88 480	2.19 56	¼	11.35 288
	GS-6A-PC6	8.00 203	10.88 276	19.12 486	3.19 81	½	11.35 288
4" 100mm	GS-6A-PC4	8.62 219	11.50 292	18.88 480	2.19 56	¼	11.35 288
	GS-6A-PC6	8.62 219	11.50 292	19.12 486	3.19 81	½	11.35 288
5 & 6" 125 & 150mm	GS-6A-PC4	9.75 248	12.62 321	18.88 480	2.19 56	¼	11.35 288
	GS-6A-PC6	9.75 248	12.62 321	19.12 486	3.19 81	½	11.35 288
	GS-6A-PC8	9.75 248	12.62 321	19.38 492	4.56 116	½	11.35 288
8" 200mm	GS-6A-PC6	12.09 307	14.97 380	19.12 486	3.19 81	½	11.35 288
	GS-6A-PC8	12.09 307	14.97 380	19.38 492	4.56 116	½	11.35 288
	GS-12A-PC6	12.78 325	16.41 417	30.56 776	3.25 83	½	17.50 445
	GS-12A-PC8	12.78 325	16.41 417	30.88 784	4.25 108	½	17.50 445
10" 250mm	GS-6A-PC6	13.50 343	16.38 416	19.12 486	3.19 81	½	11.35 288
	GS-6A-PC8	13.50 343	16.38 416	19.38 492	4.56 116	½	11.35 288
	GS-12A-PC6	14.19 360	17.81 452	30.56 776	3.25 83	½	17.50 445
	GS-12A-PC8	14.19 360	17.81 452	30.88 784	4.25 108	½	17.50 445
12" 300mm	GS-6A-PC6	15.56 395	18.44 468	19.12 486	3.19 81	½	11.35 288
	GS-6A-PC8	15.56 395	18.44 468	19.38 492	4.56 116	½	11.35 288
	GS-12A-PC6	16.25 413	19.88 505	30.56 776	3.25 83	½	17.50 445
	GS-12A-PC8	16.25 413	19.88 505	30.88 784	4.25 108	½	17.50 445
	GS-12A-PC10	16.25 413	19.88 505	31.00 787	5.25 133	¾	17.50 445
14" 350mm	GS-12A-PC6	17.56 446	21.19 538	30.56 776	3.25 83	½	17.50 445
	GS-12A-PC8	17.56 446	21.19 538	30.88 784	4.25 108	½	17.50 445
	GS-12A-PC10	17.56 446	21.19 538	31.00 787	5.25 133	¾	17.50 445
16" 400mm	GS-12A-PC6	19.00 483	22.62 575	30.56 776	3.25 83	½	17.50 445
	GS-12A-PC8	19.00 483	22.62 575	30.88 784	4.25 108	½	17.50 445
	GS-12A-PC10	19.00 483	22.62 575	31.00 787	5.25 133	¾	17.50 445
18" 450mm	GS-12A-PC8	20.25 514	23.88 607	30.88 784	4.25 108	½	17.50 445
	GS-12A-PC10	20.25 514	23.88 607	31.00 787	5.25 133	¾	17.50 445
20" 500mm	GS-12A-PC10	22.06 560	25.69 653	31.00 787	5.25 133	¾	17.50 445

Inch
Millimeter

Note: All dimensions are subject to change without notice.
Request certified drawings for use in preparing piping layout.

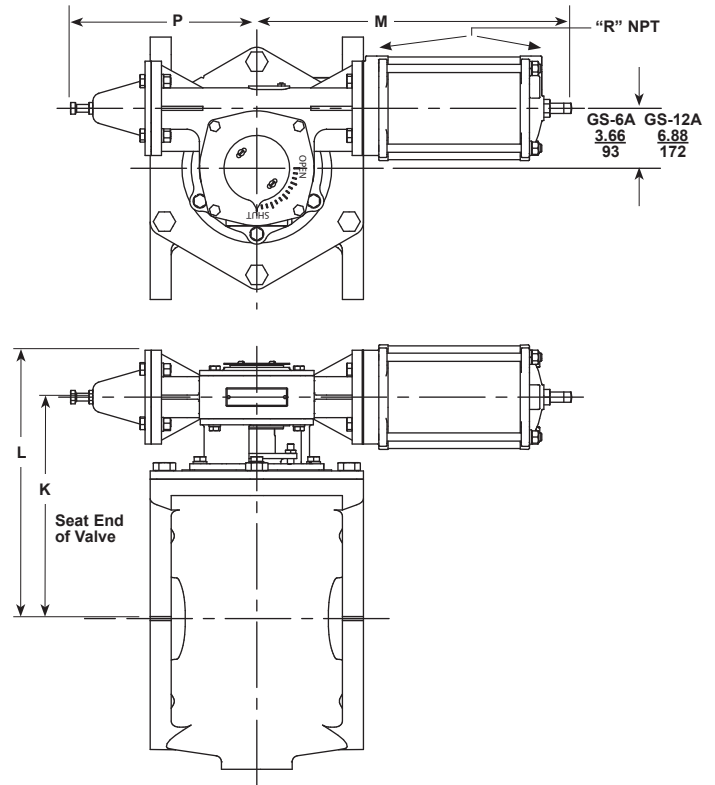

Dimensions

Spring-Return Cylinder Actuated Valves

Valve Size	Actuator Code	K	L	M	N	R (NPT)	P
3" 80mm	GS-6A-SC6	8.00 203	10.88 276	30.00 762	3.19 81	1/2	11.35 298
	GS-6A-SC8	8.00 203	10.88 276	32.19 818	4.56 116	1/2	11.35 298
4" 100mm	GS-6A-SC6	8.62 219	11.50 292	30.00 762	3.19 81	1/2	11.35 298
	GS-6A-SC8	8.62 219	11.50 292	32.19 818	4.56 116	1/2	11.35 298
5 & 6" 125 & 150mm	GS-6A-SC6	9.75 248	12.62 321	30.00 762	3.19 81	1/2	11.35 298
	GS-6A-SC8	9.75 248	12.62 321	32.19 818	4.56 116	1/2	11.35 298
8" 200mm	GS-6A-SC6	12.09 307	14.97 380	30.00 762	3.19 81	1/2	11.35 298
	GS-6A-SC8	12.09 307	14.97 380	32.19 818	4.56 116	1/2	11.35 298
	GS-12A-SC10	12.78 325	16.41 417	46.00 1168	5.25 133	3/4	17.50 445
10" 250mm	GS-12A-SC10	14.19 360	17.81 452	46.00 1168	5.25 133	3/4	17.50 445
12" 300mm	GS-12A-SC10	16.25 413	19.88 505	46.00 1168	5.25 133	3/4	17.50 445

Inch
Millimeter

Note: All dimensions are subject to change without notice.
Request certified drawings for use in preparing piping layout.

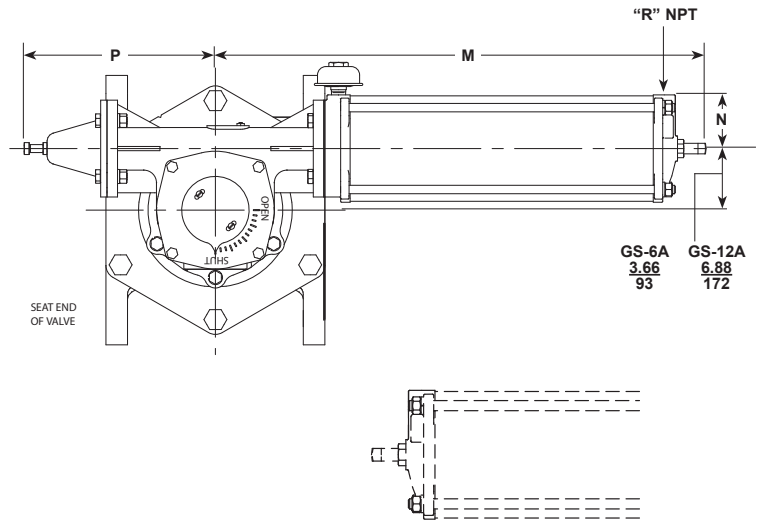

DRAWING SHOWS ACTUATOR IN SPRING TO CLOSE POSITION. DASHED LINES SHOW ACTUATOR IN SPRING TO OPEN POSITION.

Sales and Service

For information about our worldwide locations, approvals, certifications and local representative:

Web Site: DeZURIK.com E-Mail: info@DeZURIK.com



250 Riverside Ave. N. Sartell, Minnesota 56377 • Phone: 320-259-2000 • Fax: 320-259-2227

DeZURIK, Inc. reserves the right to incorporate our latest design and material changes without notice or obligation. Design features, materials of construction and dimensional data, as described in this bulletin, are provided for your information only and should not be relied upon unless confirmed in writing by DeZURIK, Inc. Certified drawings are available upon request.