

DeZURIK KGN-RSB BI-DIRECTIONAL CAST STAINLESS STEEL KNIFE GATE VALVES

Design & Construction

DeZURIK KGN-RSB Bi-Directional Cast Stainless Steel Knife Gate Valves are resilient seated valves designed for isolation, on-off applications in corrosive, abrasive liquid applications including: Pulp and Paper, Mining, Waste Water, Chemical, Petrochemical, Power and Steel.

KGN-RSB Resilient Seated Bi-Directional Knife Gate Valves are available in sizes 2-24" (50-600mm).

Bi-Directional Shutoff

The Bi-Directional Knife Gate Valve provides bubble tight shutoff in both directions up to the full rating of the valve. There is no recommended flow direction and the valve does not require line pressure to seal. The interference fit between the gate and resilient seat provides bubble tight shutoff even under the lowest pressure. The valve can be used in either direction on dead end service.

Flow Capacity

Round port design per MSS-SP-81 requirements allows high flow capacity and minimum pressure drop.

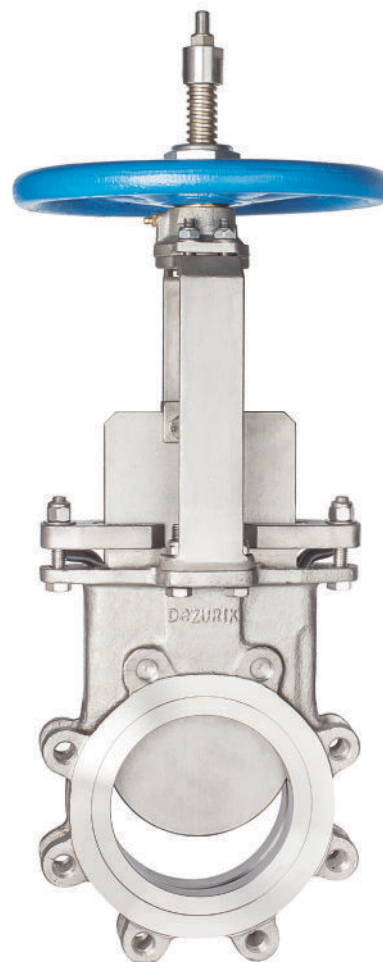
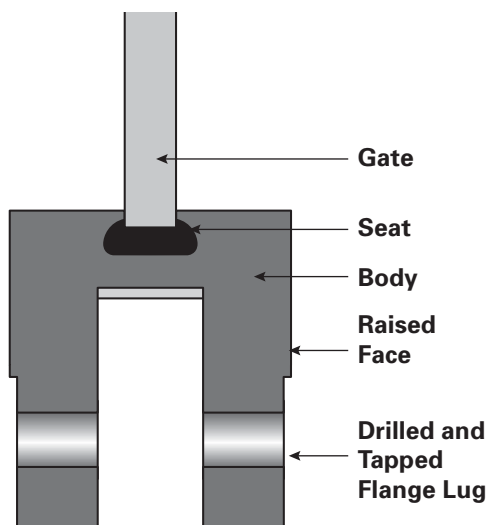

Seat Locked in Valve Body for Full Pressure, Bi-Directional, Dead End Service

The flat bottom gate provides full perimeter seating. The perimeter seat is locked into the body dovetail groove. The resilient perimeter seat provides bubble tight shutoff in either direction, even on dead end service. Valves are rated to 150 psig (1035 kPa) cold working pressure (CWP).

Choice of Resilient Seat Materials

Seats are available in your choice of EPDM, NBR or FKM to provide the seat material option that performs best for your media and operating temperature.

Long Life Packing

Square Braided PTFE packing material assures a tight seal with minimum packing gland pressure.

End Connections

Raised face body has drilled and tapped flange lugs in accordance with ASME B16.5 150 Lb. drilling dimensions. International standard flange drilling is available.

One-Piece Cast Corrosion Resistant Body

The heavy-duty, cast 316 stainless steel body provides corrosion and abrasion resistance on liquid slurry applications. The all stainless body, chest, and packing chamber provide durability and integrity for all wetted parts.

Bodies in 304 stainless steel are available.



Precision Ground Stainless Steel Gate

The 316 stainless steel gate is precision ground on all sides with beveled edges to maximize packing life. Gates in 304 stainless steel are available.

Corrosion Resistant Packing Gland

The packing gland is stainless steel for corrosion resistance. Packing gland bolts are easily accessible for adjustments.

Stainless Steel Stem & Superstructure

All valves are furnished with a stainless steel stem and superstructure that assures easy operation and dependable service.

Actuators & Accessories

Actuator options include handwheels and cylinders. A full complement of accessories are also offered.

Materials of Construction

Item	Description	Material
A1	Body	304 Stainless Steel, ASTM A351 CF-8 316 Stainless Steel, ASTM A351 CF8M
A2	Packing	MSP - Square Braided PTFE Impregnated Synthetic Fiber to 500°F (260°C) (pH Range 4-10)
A3	Gate	304 Stainless Steel, ASTM A240 316 Stainless Steel, ASTM A240
A4	Gland	316 Stainless Steel, ASTM A351 CF-8M
A6	Nut	18-8 Stainless Steel
A7	Screw	18-8 Stainless Steel
A8	Seat	EPDM - Terpolymer of Ethylene, Propylene and a Diene to 250°F (122°C) NBR - Acrylonitrile-Butadiene to 180°F (83°C) FKM - Fluoro Rubber to 400°F (204°C)
A9	Seat Retainer	304 Stainless Steel, ASTM A240 316 Stainless Steel, ASTM A240
B1	Handwheel	Cast Iron, ASTM A126 Class B
B2	Retainer	304 Stainless Steel, ASTM A351 CF-8
B3	Handwheel Nut	Carbon Steel, Zinc Plated
B4	Stopper	304 Stainless Steel, ASTM A276
B5	Stem Nut	Aluminum Bronze, ASTM B148 C95200
B6	Stem	304 Stainless Steel, ASTM A276
B7	Yoke	316 Stainless Steel, ASTM A351 CF-8M
B8	Screw	18-8 Stainless Steel
B9	Nut	18-8 Stainless Steel
B10	Screw	18-8 Stainless Steel
B11	Nut	18-8 Stainless Steel
B12	Screw	18-8 Stainless Steel
B13	Lock Nut	18-8 Stainless Steel
B14	Data Plate	18-8 Stainless Steel
B15	Pop Rivet	316 Stainless Steel, A240
B16	Grease Fitting	Brass
B17	Nut	Carbon Steel, Zinc Plated
B18	Thrust Bearing	High Carbon Chromium Steel, AISI 52100
B19	Retainer Cap	304 Stainless Steel, ASTM A276

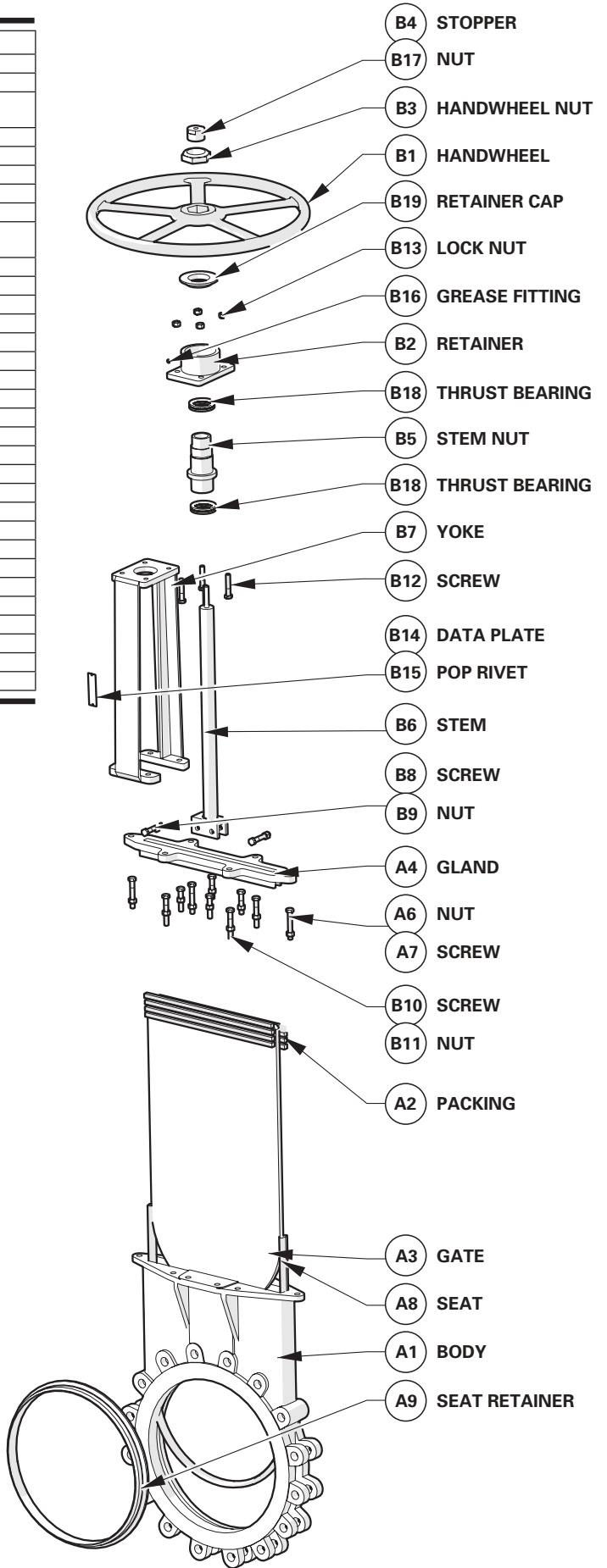

Valve Selection

Shut-Off Capabilities

Bi-Directional	Bubble Tight to Full Valve Rating
----------------	-----------------------------------

Pressure Ratings

2-24" (80-600mm)	150 psi C.W.P. (1035 kPa)
------------------	---------------------------

Applicable Standards

DeZURIK KGN-RSB Knife Gate Valves are designed and/or tested to meet the following standards:	
MSS SP-81	Stainless Steel, Bonnetless, Flanged Knife Gate Valves
MSS SP-151	Pressure testing of knife gate valves
ASME B16.5	Flanges and Flanged Fittings, ASME 150 Conforms to related drilling dimensions
International Standards	Conforms to flanged bolt guides — DIN 10 and DIN 16; ISO 7005-1/PN10 and 7005-2/PN16; BS 4504/PN10 and BS 4504/PN16; and AS 2129 Tables D and E; SANS 1123-1000 and SANS 1123-1600
TAPPI TIS 405-8	Recommendations for Stainless Steel, Bonnetless, Flanged, Wafer Knife Gate Valves. Revoked by TAPPI, Same as MSS SP-81

Flow Parameters

Valve Size	Cv* Kv* 100% Open	Port Area (in ² /cm ²)
2" 50mm	264 226	3.2 20
3" 80mm	607 520	7.0 45
4" 100mm	1096 939	11.9 77
6" 150mm	2516 2156	26.7 172
8" 200mm	4534 3885	48.7 314
10" 250mm	6729 5766	76.1 491
12" 300mm	9900 8483	111 716
14" 350mm	12575 10776	138 892
16" 400mm	16625 14246	182 1176
18" 450mm	21425 18359	234 1507
20" 500mm	26850 23008	291 1878
24" 600mm	39300 33676	425 2743

*Cv = Flow in GPM of water at
1 psi pressure drop.
Kv = Flow in m³/hr. of water at
100 kPa pressure drop.

Valve and Actuator Weights

Valve Size	Basic Valve	With Handwheel	With Cylinder		
			Size	Lbs	Kg
2" 50mm	18 9	26 12	4" (100mm) =	37	17
			6" (150mm) =	65	30
3" 80mm	26 12	40 19	4" (100mm) =	54	25
			6" (150mm) =	72	33
			8" (200mm) =	89	41
4" 100mm	33 15	49 23	6" (150mm) =	96	44
			8" (200mm) =	108	49
			10" (250mm) =	152	69
6" 150mm	53 25	73 34	8" (200mm) =	143	65
			10" (250mm) =	187	85
			12" (300mm) =	224	102
8" 200mm	84 39	108 49	8" (200mm) =	203	93
			10" (250mm) =	249	113
			12" (300mm) =	286	130
10" 250mm	132 60	159 73	14" (350mm) =	336	153
			10" (250mm) =	298	136
			12" (300mm) =	337	153
12" 300mm	176 80	214 98	14" (350mm) =	399	181
			16" (400mm) =	560	255
			18" (450mm) =	645	293
14" 350mm	220 100	291 132	10" (250mm) =	353	161
			12" (300mm) =	393	179
			14" (350mm) =	443	201
16" 400mm	331 151	408 186	16" (400mm) =	618	281
			18" (450mm) =	704	320
			20" (500mm) =	800	363
18" 450mm	441 201	564 256	12" (300mm) =	508	231
			14" (350mm) =	554	252
			16" (400mm) =	743	338
20" 500mm	580 264	708 322	18" (450mm) =	830	377
			20" (500mm) =	928	421
			14" (350mm) =	682	310
24" 600mm	725 329	864 392	16" (400mm) =	789	358
			18" (450mm) =	878	399
			20" (500mm) =	977	444
24" 600mm	725 329	864 392	14" (350mm) =	822	373
			16" (400mm) =	1044	474
			18" (450mm) =	1051	477
24" 600mm	725 329	864 392	20" (500mm) =	1151	523
			16" (400mm) =	1158	526
			18" (450mm) =	1251	568
24" 600mm	725 329	864 392	20" (500mm) =	1355	615

Pounds
Kilograms

Note: Weights are approximate and do not include crating.

Ordering

To order, simply complete the valve order code from information shown. An ordering example is shown for your reference.

Valve Style Give valve style code as follows: KGN = Cast Knife Gate Valves
--

Body Material Give body material code as follows: S1 = 304 Stainless Steel S2 = 316 Stainless Steel
--

Valve Size Give valve size code as follows:
2 = 2" (50mm) 12 = 12" (300mm) 3 = 3" (80mm) 14 = 14" (350mm) 4 = 4" (100mm) 16 = 16" (400mm) 6 = 6" (150mm) 18 = 18" (450mm) 8 = 8" (200mm) 20 = 20" (500mm) 10 = 10" (250mm) 24 = 24" (600mm)

Packing Material Give packing material code as follows: MSP = Square Braided PTFE Impregnated Synthetic Fiber to 500°F (260°C) (pH Range 4-10)
--

Body Style Give body style code as follows: RSB = Resilient Seated, Bi-Directional
--

Gate Material Give gate material code as follows: S1 = 304 Stainless Steel (Standard for S1 body material) S2 = 316 Stainless Steel (Standard for S2 body material)
--

End Connection Give end connection code as follows: F1 = ASME 150 UNC Tapping for Threads F110 = ISO 7005/PN10 Drilling F116 = ISO 7005/PN16 Drilling F1DA = AS2129 Table D Drilling F1EA = AS2129 Table E Drilling F1T = ASME 150 Through Bolting F1S10 = SANS 1123-1000 F1S16 = SANS 1123-1600 F1J1 = JIS 10 Drilling

Seat Material Give seat material code as follows: EPDM = Terpolymer of Ethylene, Propylene and a Diene to 250°F (122°C) NBR = Acrylonitrile-Butadiene to 180°F (83°C) FKM = Fluoro Rubber to 400°F (204°C)
--

Options Give option code as follows: CMC = Certificate of Material Conformance — = DeZURIK Standard Test Certification

Notes:
The limiting factor in valve selection is the lowest temperature limit of the packing or seat.

Ordering Example:
KGN,6,RSB,F1,S2,MSP,S2-EPDM*Actuator

Manual Actuators

Handwheel Actuator

All 2-24" (50-600mm) valves can be furnished with handwheel actuators. To order, add the code from the chart below to the basic valve ordering code.

Valve Size	Order Code	Maximum Pressure Differential psi/kPa
	304 SST (S1) Yoke	
2" 50mm	MN-HD10-S1	150 1035
3" 80mm	MN-HD10-S1	150 1035
4" 100mm	MN-HD10-S1	150 1035
6" 150mm	MN-HD12-S1	150 1035
8" 200mm	MN-HD12-S1	150 1035
10" 250mm	MN-HD14-S1	150 1035

Valve Size	Order Code	Maximum Pressure Differential psi/kPa
	304 SST (S1) Yoke	
12" 300mm	MN-HD14-S1	100* 690
14" 350mm	MN-HD18-S1	100* 690
16" 400mm	MN-HD18-S1	100* 690
18" 450mm	MN-HD24-S1	75* 518
20" 500mm	MN-HD24-S1	50* 345
24" 600mm	MN-HD24-S1	25* 173

NOTE: The limiting factor in actuator selection is the lowest pressure rating of the valve or actuator.

*Contact DeZURIK for actuators when pressure exceeds limits shown.

Cylinder Actuators

DeZURIK cylinder actuators are available with double-acting pneumatic or hydraulic cylinders for on/off service. Supply pressure is 60 or 80 psi (410 or 550 kPa). To order, add the proper code from the table to the valve order code. Specify hydraulic media if other than oil.

60 psi (410 kpa) Supply

Valve Size	Order Code		Maximum Pressure Differential psi/kPa	
	Carbon Steel (CS) Yoke	304 Stainless Steel (S1) Yoke	Slurries, Paper Stock	Liquids & Gases
2" 50mm	CY-PC4-CS	CY-PC4-S1	150 1034	150 1034
3" 80mm	CY-PC4-CS	CY-PC4-S1	25 172	100 689
	CY-PC6-CS	CY-PC6-S1	150 1034	150 1034
4" 100mm	CY-PC6-CS	CY-PC6-S1	100 689	150 1034
	CY-PC8-CS	CY-PC8-S1	150 1034	N/R
6" 150mm	CY-PC6-CS	CY-PC6-S1	25 172	75 517
	CY-PC8-CS	CY-PC8-S1	125 862	150 1034
	CY-PC10-CS	CY-PC10-S1	150 1034	N/R
8" 200mm	CY-PC8-CS	CY-PC8-S1	50 345	75 517
	CY-PC10-CS	CY-PC10-S1	100 689	150 1034
	CY-PC12-CS	CY-PC12-S1	150 1034	N/R
10" 250mm	CY-PC10-CS	CY-PC10-S1	50 345	75 517
	CY-PC12-CS	CY-PC12-S1	100 689	150 1034
	CY-PC14-CS	CY-PC14-S1	150 1034	N/R
12" 300mm	CY-PC12-CS	CY-PC12-S1	50 345	75 517
	CY-PC14-CS	CY-PC14-S1	75 517	125 862
	CY-PC16-CS	CY-PC16-S1	125 862	150 1034
	CY-PC18-CS	CY-PC18-S1	150 1034	N/R
14" 350mm	CY-PC12-CS	CY-PC12-S1	25 172	50 345
	CY-PC14-CS	CY-PC14-S1	50 345	75 517
	CY-PC16-CS	CY-PC16-S1	75 517	125 862
	CY-PC18-CS	CY-PC18-S1	125 862	150 1034
	CY-PC20-CS	CY-PC20-S1	150 1034	N/R

Valve Size	Order Code		Maximum Pressure Differential psi/kPa	
	Carbon Steel (CS) Yoke	304 Stainless Steel (S1) Yoke	Slurries, Paper Stock	Liquids & Gases
16" 400mm	CY-PC14-CS	CY-PC14-S1	50 345	50 345
	CY-PC16-CS	CY-PC16-S1	75 517	100 689
	CY-PC18-CS	CY-PC18-S1	100 689	125 862
	CY-PC20-CS	CY-PC20-S1	125 862	150 1034
18" 450mm	CY-PC14-CS	CY-PC14-S1	25 172	50 345
	CY-PC16-CS	CY-PC16-S1	50 345	75 517
	CY-PC18-CS	CY-PC18-S1	75 517	100 689
	CY-PC20-CS	CY-PC20-S1	100 689	125 862
20" 500mm	CY-PC16-CS	CY-PC16-S1	25 172	50 345
	CY-PC18-CS	CY-PC18-S1	50 345	75 517
	CY-PC20-CS	CY-PC20-S1	75 517	100 689
24" 600mm	CY-PC16-CS	CY-PC16-S1	N/A	25 172
	CY-PC18-CS	CY-PC18-S1	25 172	50 345
	CY-PC20-CS	CY-PC20-S1	50 345	75 517

N/R = Not Required. Use next smaller actuator

N/A = Not Available. Use next larger actuator

80 psi (550 kPa) Supply

Valve Size	Order Code		Maximum Pressure Differential psi/kPa	
	Carbon Steel (CS) Yoke	304 Stainless Steel (S1) Yoke	Slurries, Paper Stock	Liquids & Gases
2" 50mm	CY-PC4-CS	CY-PC4-S1	$\frac{150}{1034}$	$\frac{150}{1034}$
3" 80mm	CY-PC4-CS	CY-PC4-S1	$\frac{100}{689}$	$\frac{150}{1034}$
	CY-PC6-CS	CY-PC6-S1	$\frac{150}{1034}$	N/R
4" 100mm	CY-PC4-CS	CY-PC4-S1	$\frac{25}{172}$	$\frac{75}{517}$
	CY-PC6-CS	CY-PC6-S1	$\frac{150}{1034}$	$\frac{150}{1034}$
6" 150mm	CY-PC6-CS	CY-PC6-S1	$\frac{75}{517}$	$\frac{125}{862}$
	CY-PC8-CS	CY-PC8-S1	$\frac{150}{1034}$	$\frac{150}{1034}$
8" 200mm	CY-PC8-CS	CY-PC8-S1	$\frac{75}{517}$	$\frac{125}{862}$
	CY-PC10-CS	CY-PC10-S1	$\frac{150}{1034}$	$\frac{150}{1034}$
10" 250mm	CY-PC8-CS	CY-PC8-S1	$\frac{25}{172}$	$\frac{75}{517}$
	CY-PC10-CS	CY-PC10-S1	$\frac{75}{517}$	$\frac{125}{862}$
	CY-PC12-CS	CY-PC12-S1	$\frac{150}{1034}$	$\frac{150}{1034}$
12" 300mm	CY-PC10-CS	CY-PC10-S1	$\frac{50}{345}$	$\frac{75}{517}$
	CY-PC12-CS	CY-PC12-S1	$\frac{75}{517}$	$\frac{125}{862}$
	CY-PC14-CS	CY-PC14-S1	$\frac{125}{862}$	$\frac{150}{1034}$
	CY-PC16-CS	CY-PC16-S1	$\frac{150}{1034}$	N/R
14" 350mm	CY-PC10-CS	CY-PC10-S1	$\frac{25}{172}$	$\frac{50}{345}$
	CY-PC12-CS	CY-PC12-S1	$\frac{50}{345}$	$\frac{75}{517}$
	CY-PC14-CS	CY-PC14-S1	$\frac{100}{689}$	$\frac{125}{862}$
	CY-PC16-CS	CY-PC16-S1	$\frac{150}{1034}$	$\frac{150}{1034}$
16" 400mm	CY-PC12-CS	CY-PC12-S1	$\frac{25}{172}$	$\frac{50}{345}$
	CY-PC14-CS	CY-PC14-S1	$\frac{75}{517}$	$\frac{100}{689}$
	CY-PC16-CS	CY-PC16-S1	$\frac{100}{689}$	$\frac{150}{1034}$
	CY-PC18-CS	CY-PC18-S1	$\frac{125}{862}$	N/R
	CY-PC20-CS	CY-PC20-S1	$\frac{150}{1034}$	N/R

Valve Size	Order Code		Maximum Pressure Differential psi/kPa	
	Carbon Steel (CS) Yoke	304 Stainless Steel (S1) Yoke	Slurries, Paper Stock	Liquids & Gases
18" 450mm	CY-PC14-CS	CY-PC14-S1	$\frac{50}{345}$	$\frac{75}{517}$
	CY-PC16-CS	CY-PC16-S1	$\frac{75}{517}$	$\frac{100}{689}$
	CY-PC18-CS	CY-PC18-S1	$\frac{100}{689}$	$\frac{150}{1034}$
	CY-PC20-CS	CY-PC20-S1	$\frac{125}{862}$	N/R
20" 500mm	CY-PC14-CS	CY-PC14-S1	$\frac{25}{172}$	$\frac{50}{345}$
	CY-PC16-CS	CY-PC16-S1	$\frac{50}{345}$	$\frac{75}{517}$
	CY-PC18-CS	CY-PC18-S1	$\frac{75}{517}$	$\frac{100}{689}$
	CY-PC20-CS	CY-PC20-S1	$\frac{100}{689}$	$\frac{150}{1034}$
24" 600mm	CY-PC16-CS	CY-PC16-S1	$\frac{25}{172}$	$\frac{50}{345}$
	CY-PC18-CS	CY-PC18-S1	$\frac{50}{345}$	$\frac{75}{517}$
	CY-PC20-CS	CY-PC20-S1	$\frac{75}{517}$	$\frac{100}{689}$

N/R = Not Required. Use next smaller actuator
 N/A = Not Available. Use next larger actuator

Dimensions

Basic Valve with Handwheel Actuator

Valve Size	Dimensions					
	F	H	J	L	M	N
2"	2.36	1.88	5.04	15.55	13.52	10.00
50mm	60	48	128	395	343	254
3"	2.89	2.00	5.12	19.88	16.69	10.00
80mm	73	51	130	505	424	254
4"	4.23	2.00	5.12	22.78	18.66	10.00
100mm	107	51	130	579	474	254
6"	5.13	2.25	5.12	29.08	23.19	12.00
150mm	130	57	130	739	589	305
8"	6.25	2.75	5.12	35.69	27.72	12.00
200mm	159	70	130	907	704	305
10"	7.82	2.75	6.45	42.87	32.87	14.00
250mm	199	70	164	1089	835	356
12"	9.30	3.00	6.46	48.64	36.52	14.00
300mm	236	76	164	1235	928	356
14"	10.24	3.00	6.93	54.88	41.56	18.00
350mm	260	76	176	1394	1056	457
16"	11.55	3.50	7.87	62.44	47.17	18.00
400mm	293	89	200	1586	1198	457
18"	12.40	3.50	7.87	69.53	51.87	24.00
450mm	315	89	200	1766	1317	610
20"	13.82	4.50	7.87	77.40	57.71	24.00
500mm	351	114	200	1966	1466	610
24"	15.86	4.50	9.06	89.29	65.70	24.00
600mm	403	114	230	2268	1669	610

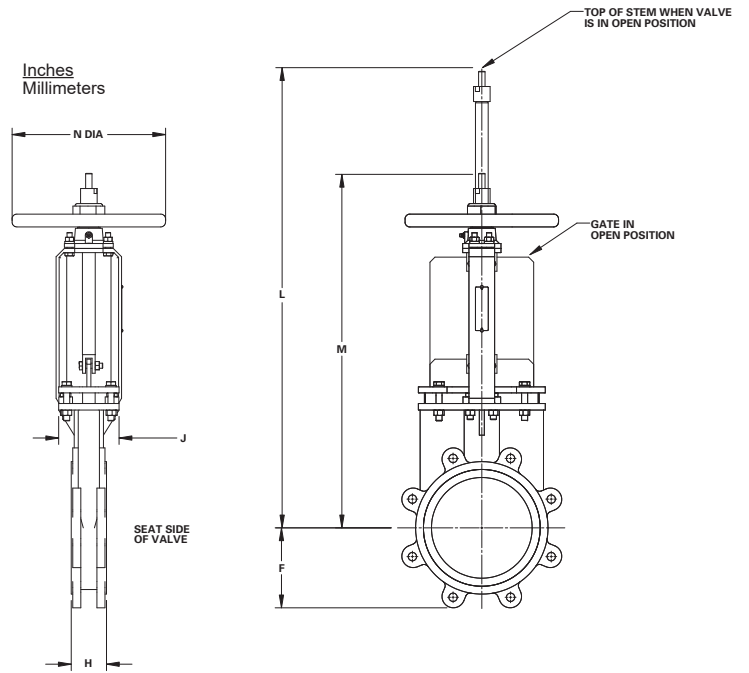

Basic Valve with Cylinder Actuator

Valve Size	Dimensions		
	F	H	J
2"	2.36	1.88	5.04
50mm	60	48	128
3"	2.89	2.00	5.12
80mm	73	51	130
4"	4.23	2.00	5.12
100mm	107	51	130
6"	5.13	2.25	5.12
150mm	130	57	130
8"	6.25	2.75	5.12
200mm	159	70	130
10"	7.82	2.75	6.45
250mm	199	70	164
12"	9.30	3.00	6.46
300mm	236	76	164
14"	10.24	3.00	6.93
350mm	260	76	176
16"	11.55	3.50	7.87
400mm	293	89	200
18"	12.40	3.50	7.87
450mm	315	89	200
20"	13.82	4.50	7.87
500mm	351	114	200
24"	15.86	4.50	9.06
600mm	403	114	230

Inches
Millimeters

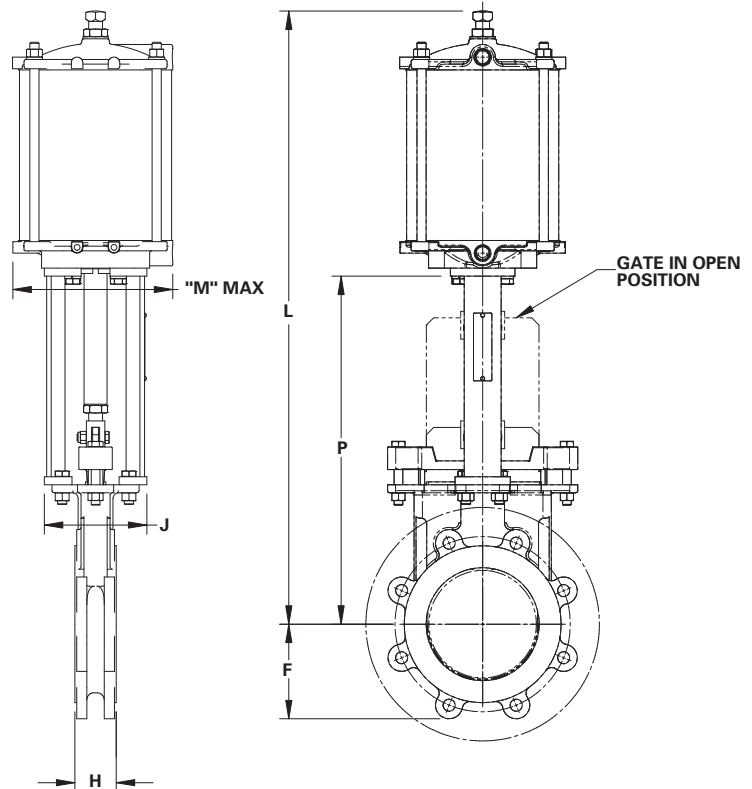

Valve Sizes 2-10" (50-250mm)

Actuator Order Code	L						M	P					
	Valve Size							Valve Size					
	2" 50mm	3" 80mm	4" 100mm	6" 150mm	8" 200mm	10" 250mm		2" 50mm	3" 80mm	4" 100mm	6" 150mm	8" 200mm	10" 250mm
CY-PC4	<u>23.96</u> 609	<u>24.89</u> 632	<u>25.74</u> 654	—	—	—	<u>5.38</u> 137	<u>13.11</u> 333	<u>13.72</u> 348	<u>14.75</u> 375	—	—	—
CY-PC6	—	<u>25.00</u> 635	<u>27.46</u> 697	<u>33.02</u> 839	—	—	<u>7.88</u> 200	—	<u>13.29</u> 338	<u>14.44</u> 367	<u>19.00</u> 483	—	—
CY-PC8	—	—	<u>30.50</u> 775	<u>33.25</u> 845	<u>39.74</u> 1009	<u>50.63</u> 1286	<u>10.50</u> 267	—	—	<u>16.31</u> 414	<u>18.87</u> 479	<u>23.16</u> 588	<u>29.58</u> 751
CY-PC10	—	—	—	<u>39.89</u> 1013	<u>41.68</u> 1059	<u>52.58</u> 1336	<u>13.00</u> 330	—	—	—	<u>21.43</u> 544	<u>23.60</u> 599	<u>29.95</u> 761
CY-PC12	—	—	—	—	<u>53.61</u> 1362	<u>55.92</u> 1420	<u>15.00</u> 381	—	—	—	—	<u>31.10</u> 790	<u>33.39</u> 848
CY-PC14	—	—	—	—	—	<u>58.95</u> 1497	<u>17.00</u> 432	—	—	—	—	—	<u>33.20</u> 843

Valve Sizes 12-24" (300-600mm)

Actuator Order Code	L						M	P					
	Valve Size							Valve Size					
	12" 300mm	14" 350mm	16" 400mm	18" 450mm	20" 500mm	24" 600mm		12" 300mm	14" 350mm	16" 400mm	18" 450mm	20" 500mm	24" 600mm
CY-PC10	<u>54.18</u> 1376	<u>63.45</u> 1612	—	—	—	—	<u>13.00</u> 330	<u>32.00</u> 813	<u>37.37</u> 949	—	—	—	—
CY-PC12	<u>57.38</u> 1457	<u>63.21</u> 1606	<u>66.14</u> 1680	—	—	—	<u>15.00</u> 381	<u>35.25</u> 895	<u>37.37</u> 949	<u>40.60</u> 1031	—	—	—
CY-PC14	<u>61.81</u> 1570	<u>63.21</u> 1606	<u>66.39</u> 1686	<u>76.96</u> 1955	<u>80.30</u> 2040	—	<u>17.00</u> 432	<u>35.25</u> 895	<u>37.37</u> 949	<u>40.60</u> 1031	<u>46.54</u> 1182	<u>49.84</u> 1266	<u>50.63</u> 1286
CY-PC16	<u>52.94</u> 1345	<u>57.50</u> 1461	<u>64.52</u> 1639	<u>70.75</u> 1797	<u>78.25</u> 1988	<u>90.08</u> 2288	<u>17.00</u> 432	<u>33.12</u> 841	<u>36.49</u> 927	<u>41.59</u> 1056	<u>45.60</u> 1158	<u>50.93</u> 1294	<u>58.83</u> 1494
CY-PC18	<u>53.19</u> 1351	<u>57.75</u> 1467	<u>64.77</u> 1645	<u>71.00</u> 1803	<u>78.50</u> 1994	<u>90.33</u> 2294	<u>19.00</u> 483	<u>33.12</u> 841	<u>36.49</u> 927	<u>41.59</u> 1056	<u>45.60</u> 1158	<u>50.93</u> 1294	<u>58.83</u> 1494
CY-PC20	—	<u>58.00</u> 1473	<u>65.02</u> 1652	<u>71.25</u> 1810	<u>78.75</u> 2000	<u>90.58</u> 2301	<u>21.00</u> 533	—	<u>36.49</u> 927	<u>41.59</u> 1056	<u>45.60</u> 1158	<u>50.93</u> 1294	<u>58.83</u> 1494

Sales and Service

For information about our worldwide locations, approvals, certifications and local representative:

Web Site: DeZURIK.com E-Mail: info@DeZURIK.com



250 Riverside Ave. N. Sartell, Minnesota 56377 • Phone: 320-259-2000 • Fax: 320-259-2227

DeZURIK, Inc. reserves the right to incorporate our latest design and material changes without notice or obligation. Design features, materials of construction and dimensional data, as described in this bulletin, are provided for your information only and should not be relied upon unless confirmed in writing by DeZURIK, Inc. Certified drawings are available upon request.