

DEZURIK .5–3" (15–80MM) PEC ECCENTRIC PLUG VALVES

Time-Tested Quality

In thousands of installations worldwide, DeZURIK Eccentric Plug Valves have a proven record of long-term reliability. A wide variety of value-added design features and unmatched economy have made it the preferred choice of engineering, operations and maintenance personnel.

Designed for Demanding Applications

DeZURIK Eccentric Plug Valves are used to handle clean and dirty liquids, sludge, slurries and gases. They can be used for either isolation/shutoff or throttling/control services. Eccentric plug valves are used in water treatment, wastewater treatment, power, chemical, mining and pulp & paper.

An Exceptional Control Valve

DeZURIK Eccentric Plug Valve provides excellent throttling control and accuracy. Permanently lubricated bearings and eccentric action reduces stiction, allowing for small incremental and controllable steps. The one-piece cast plug and shaft effectively eliminates mechanical backlash and hysteresis. In addition, the firm coupling connecting the valve to the actuator increases measurable accuracy.

High Flow Capacity

Clean interior design and straight-through flow allow high maximum capacity with minimum pressure drop.

Wide Selection of Body Materials

DeZURIK offers the most complete line of eccentric body materials to meet the requirements of a broad range of applications up to 285 psi (1965 kPa). Materials available include cast iron, acid-resistant bronze, carbon steel, stainless steel, Alloy 20, Monel and Hastelloy C.

Variety of End Styles

A complete choice of end styles includes threaded to ASME Class 150, DIN, BS or JIS standards; flange-drilled to ASME Class 125/150 standards; mechanical joint (3" only); and grooved per AWWA C606.

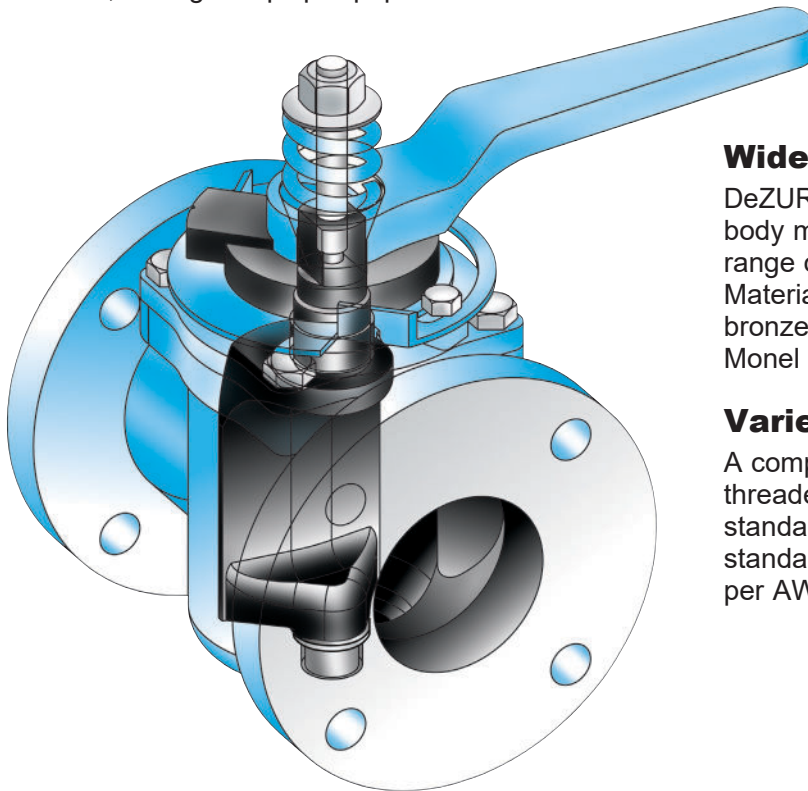

.5-3" Eccentric Plug Valves

One-Piece Cast Plug

Eccentric Plug Valves in sizes .5–3" (15–80mm), feature a plug with upper and lower shaft in a one-piece casting. The straight plug face allows for inherent linear flow characteristic.

The plug rotates completely out of flow, allowing high, straight-through flow capacity. Because the plug is out of the flow path, it provides increased plug life in abrasive applications.

Resilient Plug Facings for Dead-Tight Shutoff

Eccentric Plug Valves are available with a variety of resilient plug facings suitable for temperatures up to 450° F (232° C).

Resilient-faced plugs provide dead-tight shutoff without the use of sealing lubricants. Even if small solids are trapped between the plug and seat, the resilient facing provides tight shutoff and prevents seat damage. The resilient plug design provides drip-tight shutoff on wet-service applications up to the full pressure rating of the valve with pressure in either direction.

Materials available include chloroprene (CR), acrylonitrile-butadiene (NBR), hard natural rubber (NRH), chloro-isobutene isoprene (CIIR), hard rubber with chloroprene overlay (NRCR) and fluoro rubber (FKM).

All-metal plugs are also available for high-temperature or throttling applications where dead-tight shutoff is not required.

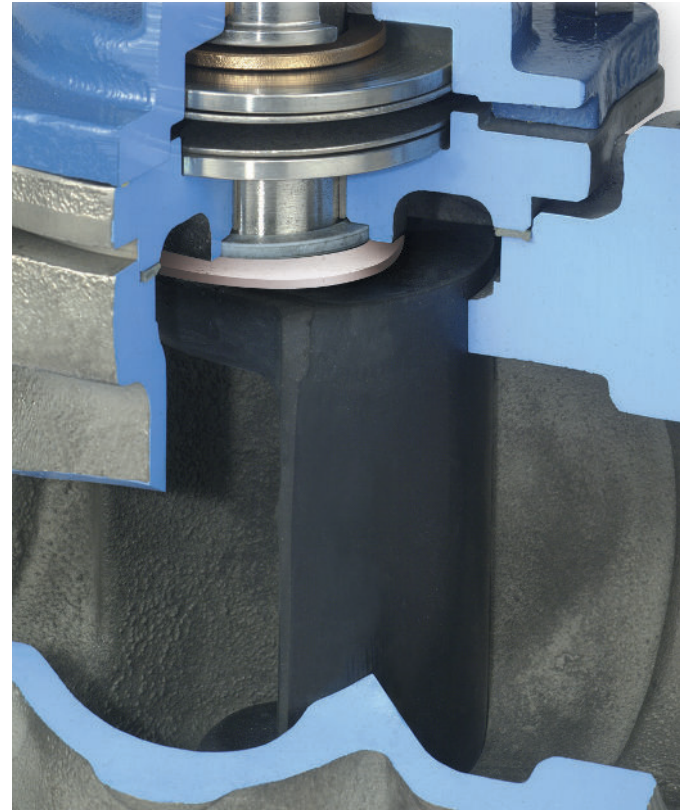

Bolted Bonnet

All .5–3" (15–80mm) valves have a rugged, one-piece bolted bonnet for maximum strength. It houses upper bearing and shaft seals to increase cycle life. If maintenance is ever required, its easy disassembly allows access to internal components.

Corrosion-Resistant Bearings

Heavy-duty bearings resist corrosion to prevent binding and assure lasting easy valve operation without lubrication. These rugged stainless steel bearings are furnished in the bonnet and body of all valves.

Long-Life Stem Seals

A variety of stem-seal materials provides maintenance-free sealing that matches valve performance and ensures long life and reliability. Grit Excluders prevent entry of media into the upper and lower journals.

.5-3" Eccentric Plug Valves



Compatible With Standard Actuators

The mounting pad on Eccentric Plug Valves is compatible with standard DeZURIK actuators. The ISO bolt pattern allows standardization of actuators on a variety of DeZURIK valves, reducing inventory. A wide range of manual actuators, including manual worm-gear handwheels, chainwheels, square nut drives and levers may also be ordered.

Accessories

A full line of accessories designed to match DeZURIK actuator systems is also available, including positioners, solenoids, switches, speed controls, extensions and floorstands.

See Eccentric Plug Valve Animation on our website dezurik.com

Eccentric Action/Rectangular Port

Quarter turn eccentric action and resilient plug facings ensure lasting bubble-tight shutoff. As the eccentric plug rotates from open to closed, it moves into a raised eccentric seat.

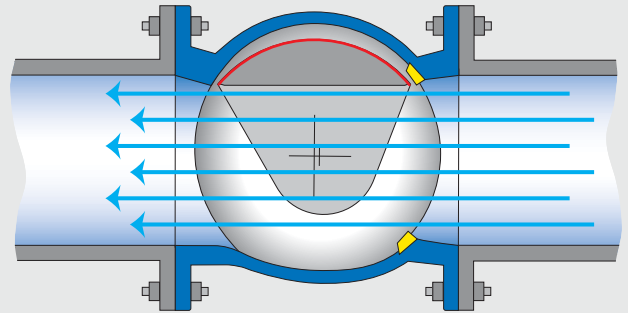

Open

In the open position, the plug is out of the flow path.

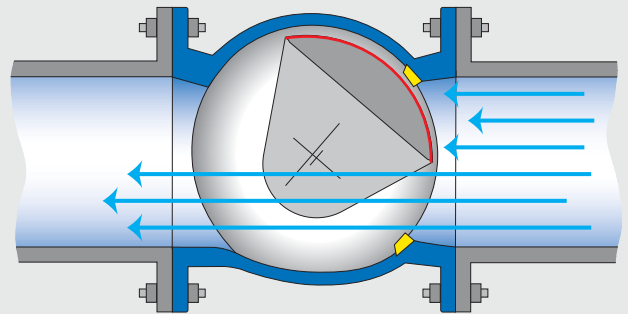

Closing

As the plug closes, it moves eccentrically toward the seat without scraping the seat or body walls, so there is no plug binding or wear.

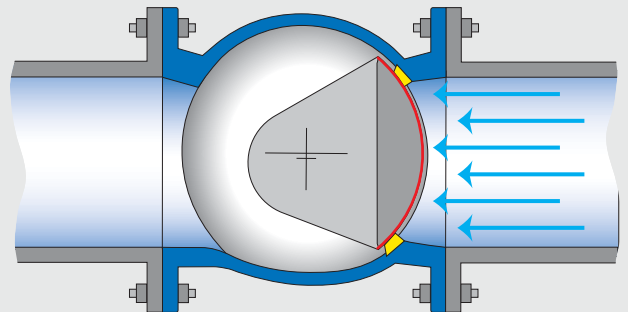

Closed

The resilient plug face makes full, uniform, firm contact with the seat for bubble-tight shutoff.

Materials of Construction

Materials of Construction

Item	Description	Material
A1	Body	Cast Iron, ASTM A126, Class B
		Ductile Iron, ASTM A536
		Acid Resistant Bronze, ASTM B427 Alloy C90800
		Carbon Steel, ASTM A216, Grade WCB
		316 Stainless Steel, ASTM A743, Grade CF-8M
		Alloy 20
		Hastelloy C
		Monel
A2	Bearing	316L Stainless Steel, Sintered Stainless Steel
A3	Plug	Metal (same metal as valve body except Cast Iron and Carbon Steel which have 316 Stainless Steel Plug)
		Rubber Faced (same metal as valve body except Carbon Steel which has 316 Stainless Steel Plug)
	Plug Facing	CR Chloroprene
		NBR Acrylonitrile-Butadiene
		NRH Hard Natural Rubber
		CIIR Chloro-Isobutene Isoprene
		NRCR Hard Rubber with Chloroprene Overlay
		FKM Fluoro Rubber
		NBRD Acrylonitrile-Butadiene
	3" NRCR Plugs and CIS bodies only	CR Chloroprene
A5	Gasket	Non-asbestos filler in Styrene-Butadiene Rubber binder
A6	Bonnet	Same material as body
A7	Bearing	316L Stainless Steel, Sintered Stainless Steel
A8	Bonnet Screws	Carbon Steel, Grade 2, Zinc Plated (CI, ABZ, NR Body Materials)
		Carbon Steel, Grade 5, Zinc Plated (CS Body Material)
		18-8 Stainless Steel (S2, AA, HC, ML Body Materials)
A9	Felt Washer (Lever, MNA and NT actuators only)	SAE F-7
A10	Grit Excluder Stem Seal	NBR Acrylonitrile-Butadiene, PTFE and NBR Rubber
		FKM Fluorinated Hydrocarbon, PTFE and FKM Rubber
		PTFE
		Flexible Graphite
A11	U-Ring Filler	FKM and NBR only
A12	Stud, Plug	Carbon Steel, Grade 2, Zinc Plated
A18	Grit Excluder	PTFE (Not included on CIS valves)

*Indicates transfer molded process

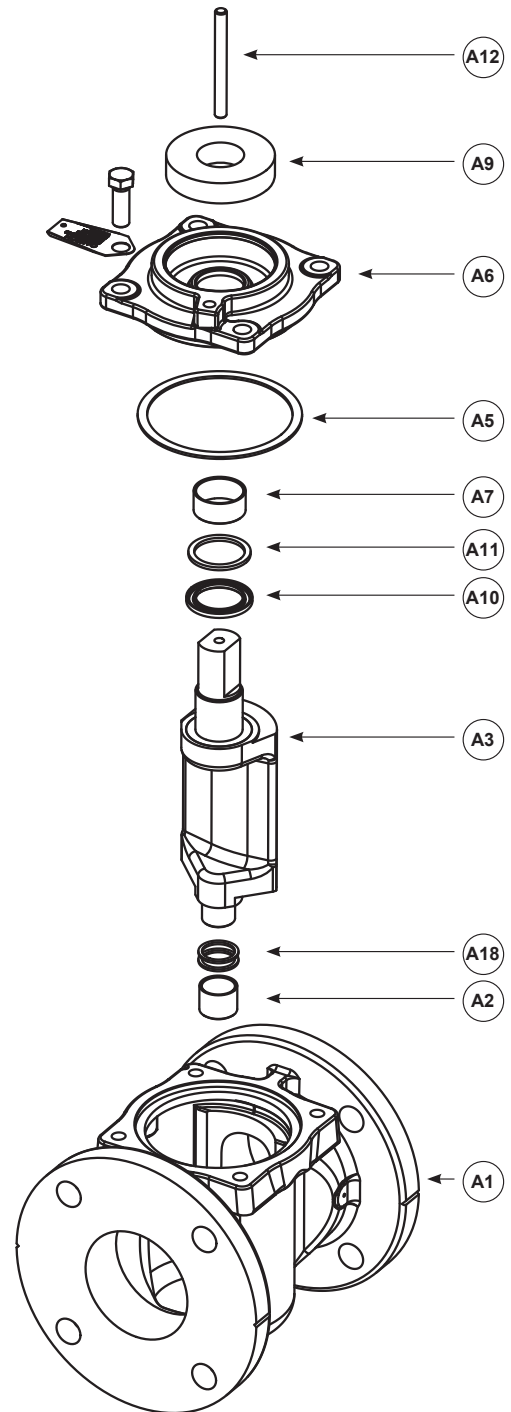

Applicable Standards

DeZURIK .5-3" (15-80mm) Eccentric Plug Valves are designed and/or tested to meet the following standards.	
AWWA C517-16	Valves conform to AWWA Standard AWWA C517-16 Eccentric Plug Valves
ASME B16.1, ASME B16.5, ASME B16.42	ASME flange drilling conforms to ASME B16.1 Class 125 and ASME B16.5 Class 150, and ASME B16.42 Class 150.
ASME B1.20.1	ASME threaded end connections conform to the NPT requirements of ASME B1.20.1.
AWWA C111/A21.11	Mechanical-joint end connections conform to AWWA C111/A21.11.
AWWA C606	Grooved joint end connections conform to AWWA C606.
ISO 2084 British Standard 4504 German Standard DIN 2532	Metric 10 bar flange drilling conforms to the NP 10 requirements of International Standard ISO 2084, to the 10 bar requirements of British Standard 4504, and to the NP 10 requirements of German Standard DIN 2532.
	Metric 16 bar flange drilling conforms to the NP 16 requirements of International Standard ISO 2084, to the 16 bar requirements of British Standard 4504, and to the NP 16 requirement of German Standard DIN 2533.
DIN 259	DIN parallel threaded end connections conform to German Standard DIN 259.
British Standard BS 10	British Table D flange drilling and Table E flange drilling conform to British Standard BS 10.
British Standard BS 21	British tapered thread end connections conform to British Standard BS 21.
JIS B 0203	Japanese 10 bar flange drilling conforms to Japanese Industrial Standard JIS B 0203.
JIS B 0203	Japanese tapered threaded end connections conform to Japanese Industrial Standard JIS B 0203.
NFPN E 03-004	French tapered threaded end connections conform to French Standard NFPN E 03-004.

Pressure Ratings

C.W.P. non-shock working pressure ratings

Cast Iron	175 psi (1207 kPa)
Ductile Iron***	285 psi (1965 kPa)
Acid Resisting Bronze	200 psi (1379 kPa)
Aluminum	150 psi (1034 kPa)
Carbon Steel**	285 psi (1965 kPa)
Stainless Steel** and Other Alloys	275 psi (1896 kPa)
Hard and Soft Rubber Lined Cast Iron* Body	175 psi (1207 kPa)

* Cast Iron conforms to ANSI B16.1 Class 125 Hydrostatic Test.

** Carbon Steel and 316 Stainless Steel conform to ANSI B16.5 Class 150.

*** Ductile Iron conforms to ASME B16.42 Class 150 hydrostatic test.

Valve Weights

Valve Size	Body Material lb (kg)									
	Cast Iron & Ductile Iron		Bronze, Acid Bronze		Aluminum		Carbon Steel		Stainless Steel	
	Flanged	Threaded	Flanged	Threaded	Flanged	Threaded	Flanged	Threaded	Flanged	Threaded
.5" (15mm)	8 (4)	5 (2)	8 (4)	5 (2)	4 (2)	3 (1)	7 (3)	5 (2)	7 (3)	5 (2)
.75" (20mm)	8 (4)	5 (2)	8 (4)	5 (2)	4 (2)	3 (1)	8 (4)	5 (2)	8 (4)	5 (2)
1" (25mm)	8 (4)	5 (2)	9 (4)	5 (2)	4 (2)	3 (1)	9 (4)	5 (2)	9 (4)	5 (2)
1.25" (32mm)	12 (5)	8 (4)	13 (6)	9 (4)	6 (3)	4 (2)	11 (5)	8 (4)	11 (5)	8 (4)
1.5" (40mm)	13 (6)	8 (4)	14 (6)	9 (4)	6 (3)	4 (2)	12 (5)	8 (4)	12 (5)	8 (4)
2" (50mm)	20 (9)	12 (5)	23 (10)	13 (6)	10 (5)	7 (3)	21 (10)	12 (5)	21 (10)	12 (5)
2.5" (65mm)	29 (13)	19 (9)	34 (15)	20 (9)	14 (6)	10 (5)	32 (15)	19 (9)	32 (15)	19 (9)
3" (80mm)	42 (19)	31 (14)	45 (20)	32 (15)	21 (10)	16 (7)	45 (20)	31 (14)	45 (20)	31 (14)

Note: Weight includes levers. Weight added for adapters: 1 lb. / .5 kg

Valve Selection

Cv/Kv Values

Valve Size	Port Area %	Cv/Kv
.5" (15mm)	204	10/9
.75" (20mm)	117	20/17
1" (25mm)	72	33/29
1.25" (32mm)	115	74/64
1.5" (40mm)	84	74/64
2" (50mm)	91	148/128
2.5" (65mm)	99	236/204
3" (80mm)	80	330/285

*Cv Values = Flow in GPM of water at 1 psi pressure drop.
Kv Values = Flow in m³/hr of water at 100 kPa pressure drop.

Note: Cv/Kv Values will be slightly higher for valves with threaded end and for metal seated valves. Sizing data is based on discharge into conduit rather than atmosphere.

Flow Characteristic

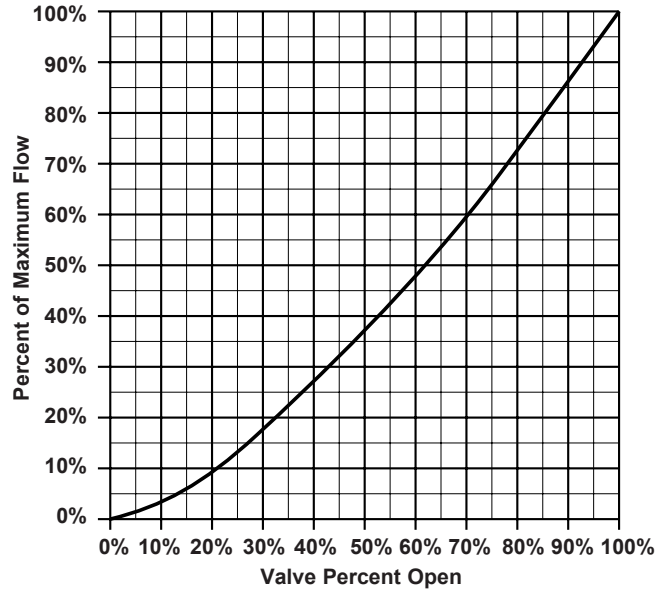

Valve Sizing

Flow Charts

Valve Fully Open

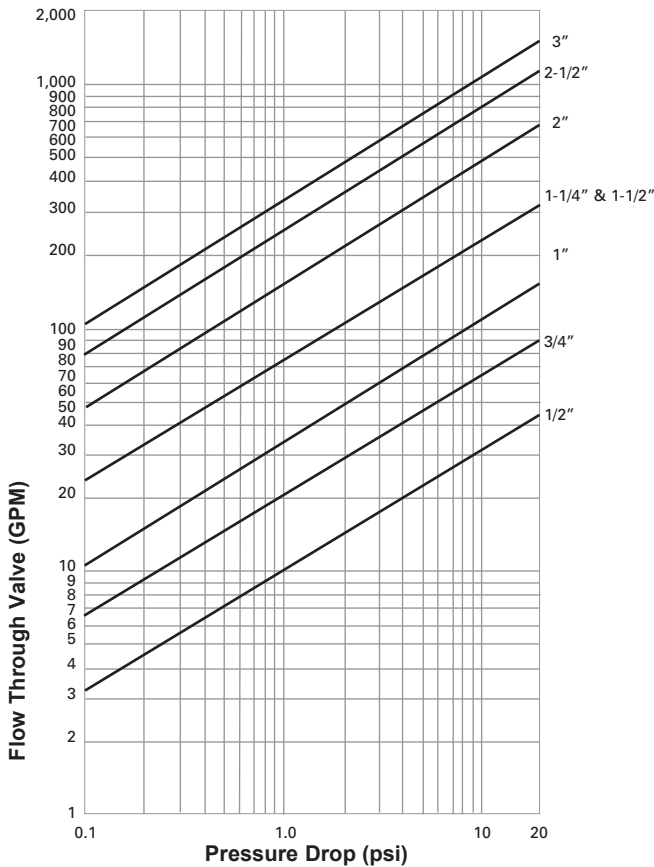

Valve Fully Open - Metric

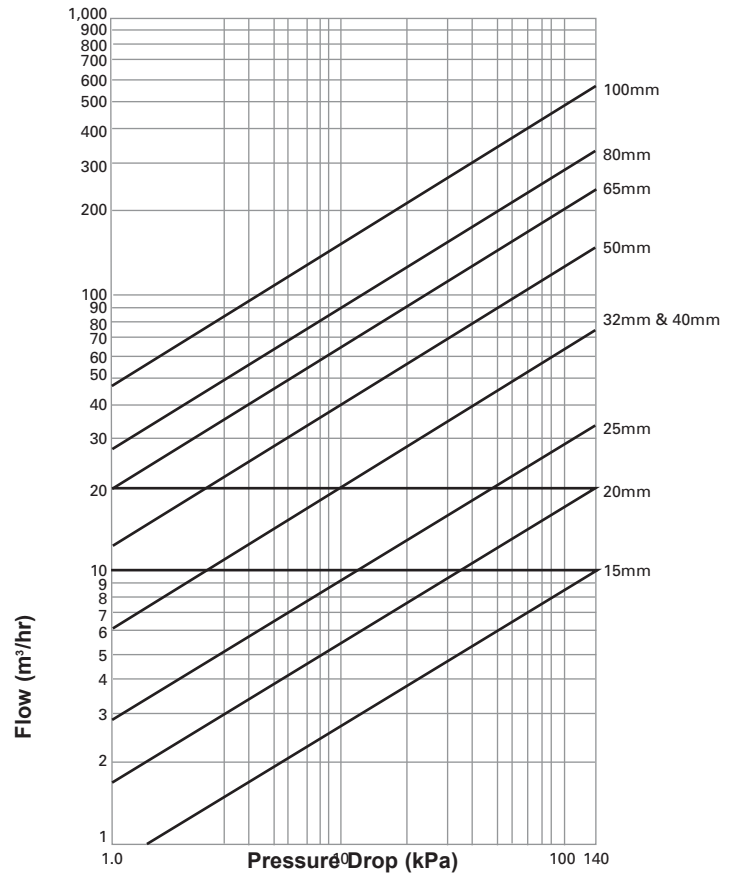

Installation Instructions

Installation Instructions

The type of materials carried in the pipeline and the location of the valve determine the correct installation procedure:

Liquids Without Suspended Solids and Clean Gases

1. Before installation, remove foreign material such as weld spatter, oil, grease, and dirt from the valve and pipeline.
2. Install the valve as shown in Figure 1.
3. Ensure the valve and flanges are concentric to ensure proper flange sealing.
4. Tighten the flange bolts or studs in a criss-cross pattern.

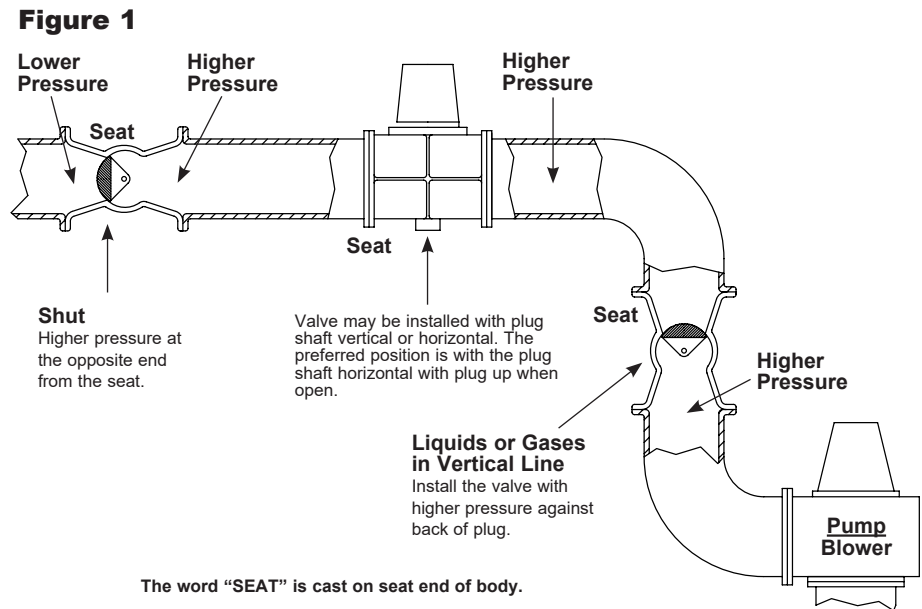

Suspended Solids and Dirty Gases

If the pipeline carries suspended solids such as paper stock of 2% or higher consistency, mining slurry, or raw sewage:

1. Before installation, remove foreign material such as weld spatter, oil, grease, and dirt from the valve and pipeline.
2. Install the valve as shown in Figure 2.
 - A. In horizontal pipelines install valve so plug is horizontal and rotates upward as valve opens.
 - B. For vertical pipelines, install valve with the end marked "Seat" at top of valve.
3. Tighten the flange bolts or studs in a criss-cross pattern.
4. Ensure the valve and flanges are concentric to ensure proper flange sealing.

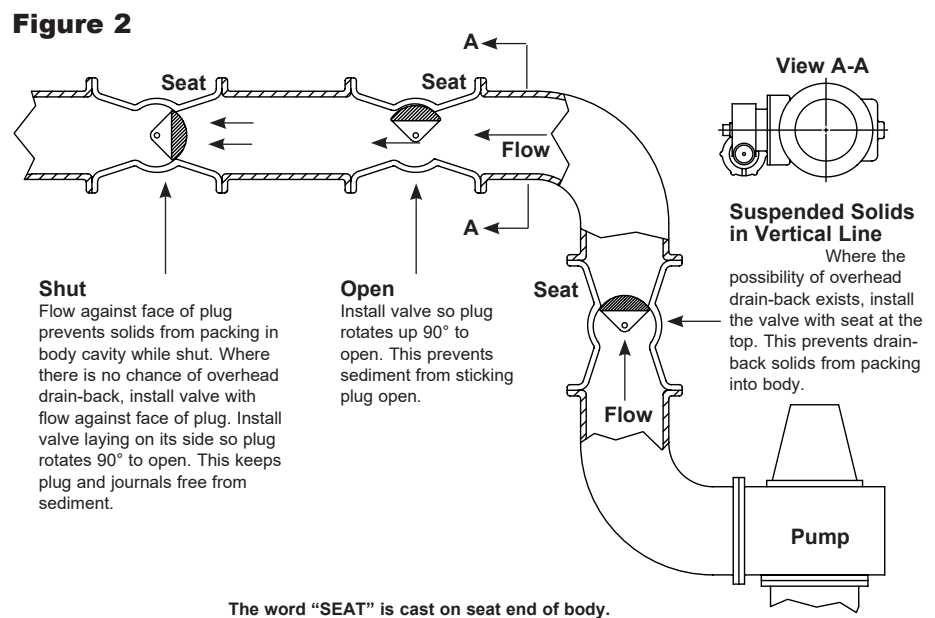

FOR PUMP ISOLATION SERVICE, INSTALL THE VALVE WITH THE SEAT SIDE OPPOSITE THE PUMP AND WITH THE PLUG ROTATING TO THE TOP OF THE PIPELINE IN THE OPEN POSITION.

Ordering

Ordering

To order, simply complete the valve order code from the information shown.

Valve Style

Give valve style code as follows:

PEC = Eccentric Plug

Valve Size

Give valve size code as follows:

.5 = .5" (15mm)	1.5 = 1.5" (40mm)
.75 = .75" (20mm)	2 = 2" (50mm)
1 = 1" (25mm)	2.5 = 2.5" (65mm)
1.25 = 1.25" (32mm)	3 = 3" (80mm)

End Connection

F1 = Flanged, ANSI Class 125/150 (except .5-1.5" (15-40mm) Cast Iron)
F110 = Flanged, Class 150 DIN 10 or BS4504/10
F116 = Flanged, Class 150 DIN 16 or BS4504/16
T1 = Threaded, ANSI Class 150
F1D = Flanged, Class 150 BS Table D Drilling
F1E = Flanged, Class 150 BS Table E Drilling
F1J1 = Flanged, Class 150 JIS 10 Drilling
GS = DIN Threaded (Parallel)
HS = BS Threaded (Taper)
JS = JIS Threaded (Taper)
MJ = Mechanical-Joint (3" (80mm) Cast Iron only)

Body Material

Give body material code as follows:

CI = Cast Iron
CIH = Cast Iron, Hard Rubber Lined (3" Flanged only)
CIN = Cast Iron, Nickel Welded Seat (3" only)
CIS = Cast Iron, Soft Rubber Lined (3" Flanged only)
DI = Ductile Iron
DIN = Ductile Iron, Nickel Welded Seat (3" only)
DIS = Ductile Iron, Soft Rubber Lined (3" Flanged only)
ABZ = Acid Bronze
CS = Carbon Steel (2-3" only)
S2 = 316 Stainless Steel
AA = Alloy 20
HC = Hastelloy C
ML = Monel

Ordering Example:

PEC,2,F1,CI,NBR,CR,*LV

Packing

Give packing code as follows:

NBR = Acrylonitrile-Butadiene Reinforced filler in a PTFE U-ring .5"-3" (15-80mm) all resilient faced plugs except FKM and except 3" with CIH body material. -20 to 180° F (-29 to 83° C)
FKM = Fluorinated Hydrocarbon filler in a PTFE U-ring .5-3" (15-80mm) all metal and FKM plugs -20 to 450° F (-29 to 232° C)
T = Solid PTFE .5-3" (15-80mm) all metal plugs. Must be used with CIS or DIS body material, -20 to 450° F (-29 to 232° C)
G2 = Flexible Graphite, -20 to 1000° F (-29 to 538° C) .5-3" all metal plugs

Plug Facing

Give plug facing code as follows:

M = Metal
CR = Chloroprene, -20 to 180° F (-29 to 83° C)
NBR = Acrylonitrile-Butadiene, -20 to 180° F (-29 to 83° C) For petroleum applications
NBRD = Acrylonitrile-Butadiene, -20 to 180° F (-29 to 83° C) For chemical and dry applications
NRH = Hard Natural Rubber, -20 to 180° F (-29 to 83° C) Use on 3" CIH Body only
CIIR = Chloro-Isobutene Isoprene -20 to 250° F (-29° to 121° C)
NRRCR = Hard Rubber with Chloroprene Overlay Use on CIH body only -20 to 180° F (-29 to 83° C)
FKM = Fluoro Rubber -20 to 450° F (-29 to 232° C) used with FKM or T packing only
EPDM = Terpolymer of Ethylene Propylene & A Diene -20 to 250° F (-29 to 121° C)

Note:

The limiting factor in valve selection is the lowest temperature limit of the packing or plug facing.

Options

Give options codes as follows:

AIS = Valves conform to H.R. 3547 Consolidated Appropriations Act, 2014 Section 436. Available with CI, CIH, CIS, CS, DI, DIS, S2 Body Materials only.
BAA = Buy American Act
CMC = Certificate of Material Conformance
ST3 = Pennsylvania Steel Procurement Act
BV1 = Balancing Valve with 1/8" air valve fittings. Available with CI or DI Body Material & F1 or T1 End Connection.
BV2 = Balancing Valve with 1/8" quick disconnect couplings. Available with CI or DI Body Material & F1 or T1 End Connection.
DST = Dry Seat Test
DTR = DeZURIK Standard Certified Production Hydrostatic Shell & Seat Test Report
PD = 1/8" Pipe Tap Downstream
PU = 1/8" Pipe Tap Upstream
PDU = 1/8" Pipe Tap Upstream & Downstream. Available with CI Body Material and F1 & T1 End Connection only.
S2 = 316 Stainless Steel Plug (Resilient plugs only)
GR = Grease Fittings in Body (except Rubber Lined Valves CIH, CIS & DIS)
TB = Certified Seat Leak Test Both Directions per AWWA C517
TD_ = Certified Seat Leak Test Direct Pressure per AWWA C517
TR_ = Certified Seat Leak Test Reverse Pressure per AWWA C517

Manual Actuators

Pressure Ratings

Direct shutoff pressure differentials for lever, nut and adapter actuated valves must not exceed 150 psi (1030 kPa). Reverse shutoff differentials must not exceed 25 psi (170 kPa). If valves must seal higher reverse pressure, use handwheel actuators.

Non-Removable Lever (LV)

.5–3" (15–80mm) valve design includes a bolted-on, non-removable lever. To order, add code LV to basic valve code.

Ordering Example:

PEC,2,F1,C1,NBR,CR*LV

Adjustable Memory Stop

All .5–3" (15–80mm) lever actuated valves are furnished with an adjustable, open position memory stop as standard. With the stop ring adjusted to the desired open position, the valve can be closed and reopened to the same position. This feature makes the valve ideal for air conditioning balancing service. Valves with resilient seats provide double-duty on this application by combining balancing and shutoff in a single valve.

Stainless Steel Bolting

On LV, HLA or MNA actuators, includes stainless steel spring, stud nuts, washers and bonnet bolts. To order, add SB16 for 316 stainless steel after the actuator order codes

Ordering Example:

PEC,2,F1,C1,NBR,CR,*LV,SB16

Adapter for Handles (HLA)

Furnished as standard on .5–3" (15–80mm) valves. Must be ordered to use LVR Removable Lever or CH Chain Handle. To order, add code HLA to basic valve code.

Ordering Example:

PEC,2,F1,C1,NBR,CR*HLA

Removable Lever (LVR)

For use with HLA Adapter. Removable levers must be ordered separately.

Order Code	Size
ACC*LVR103	.5–2" (15–50mm)
ACC*LVR105	2.5–3" (65–80mm)

Ordering Example:

PEC,2,F1,C1,NBR,CR*HLA

ACC*LVR103

DeZURIK.com



Chain Handle (CH)

For use with HLA Adapter. Chain Handle must be ordered separately by giving code ACC*CH followed by a dash and valve size.

Order Code	Size
ACC*CH-.5	.5" (15mm)
ACC*CH-.75	.75" (20mm)
ACC*CH-1	1" (25mm)
ACC*CH-1.25	1.25" (30mm)
ACC*CH-1.5	1.5" (40mm)
ACC*CH-2	2" (50mm)
ACC*CH-2.5	2.5" (65mm)
ACC*CH-3	3" (80mm)

Ordering Example:

PEC,2,F1,C1,NBR,CR*HLA

ACC*CH-2

Chain for Chain Handle (CN)

Order as a separate item by giving code ACC*CN101. Specify number of feet required and number of pieces.

Ordering Example:

ACC*CN101

Chain 1 piece 10 feet long

MNA Adapter for Lever Actuated Valves

The MNA adapter is required in order to use Floor Boxes (FB), Valves Boxes (VB), Extension Fittings (EF), Tee Wrenches (WRT) and Extended Nut (ENLV). To order, add MNA to basic valve code.

Ordering Example:

PEC,2,F1,C1,NBR,CR*MNA

Accessories — Manual Actuators

EF Extension for Lever Actuated Valves

Includes extension pipe, bearing plate and couplings. Valves for use with EF Extension Assembly must be ordered with MNA adapters. Order Extension Assembly as a separate item by giving code ACC*EF followed by a dash and valve size. Specify length from centerline of valve to bottom of bearing plate. When ordering for use with FS101 Floor Stand, give dimension from centerline of valve to base of floor stand.

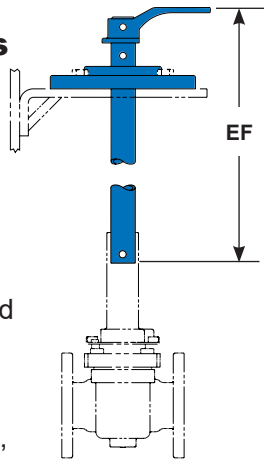

Ordering Example:

ACC*EF-3

Centerline of valve to bottom of bearing plate
110 inches (2795mm)

FS101 Floor Stand for Lever Actuated Valves

Includes floor stand only. For extension pipe and fittings, order EF Extension Assembly. Lever actuated valves for use with EF Extension and FS101 Floor Stand must be ordered with adapters. Order floor stands as a separate item.

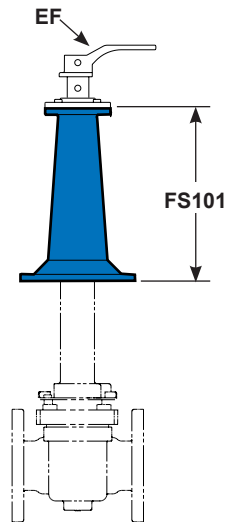

Ordering Example:

ACC*FS101

WRT Tee Wrench

Valves for Tee Wrench operation must be ordered with MNA Adapter or ENLV Extended Nut. To order Tee Wrenches, list order code per table below.

Wrench Length	Valve Size	
	.5-2" (15-50mm)	2.5-3" (65-80mm)
4 Feet (120cm) (Standard)	ACC*WRT250-B	ACC*WRT250-C
5 Feet (150cm)	ACC*WRT251-B	ACC*WRT251-C
6 Feet (185cm)	ACC*WRT252-B	ACC*WRT252-C
7 Feet (215cm)	ACC*WRT253-B	ACC*WRT253-C
8 Feet (245cm)	ACC*WRT254-B	ACC*WRT254-C

Ordering Example:

ACC*WRT250-A

FB Floor Box for Lever Actuated Valves

Includes floor box and cover only. Can be used with valves having operating nut mounted the valve or extended with top of 2" (50mm) from top of floor box. valves for use with floor boxes are Wrench actuated (order separately). Order extended operating nuts (ENLV) separately. Floor box requires MNA adapters (order separately). Order floor boxes separately. Specify ACC*FB and depth of floor box in 1" (25mm) increments from 6-18" (150-455mm). Standard depth is 6" (150mm).

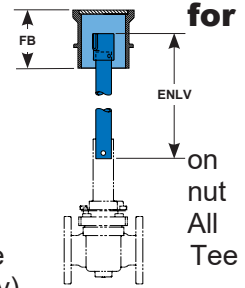

Ordering Example:

ACC*FB6

ENLV Extended Nut for Lever Actuated Valves

For use with ACC*FB Floor Box or VB Valve Box. Includes operating nut, couplings and pipe. Valves for use with ENLV Extended Nut must be ordered with MNA adapters. All valves for use with ENLV are Tee Wrench activated (order separately). Order as a separate item by giving ACC*ENLV followed by a dash and valve size. Give required length from centerline of valve to top of nut.

Valve Size	Minimum Dimension C/L of Valve to Top of Nut
.5-1" (15-25mm)	9.25" (235mm)
1.25-1.5" (32-40mm)	9.63" (245mm)
2" (50mm)	11.00" (280mm)
2.5" (65mm)	13.50" (345mm)
3" (80mm)	14.13" (360mm)

Ordering Example:

ACC*ENLV-3

Centerline of valve to top of valve nut 126 inches (3200mm)

VB Valve Box for Lever Actuated Valves

Valve boxes are for use with lever actuated valves. Includes valve box and cover. Can be used with valves having operating nut mounted on the valve or extended with top of nut 6" (150mm) from top of valve box. All valves for use with valve boxes are Tee Wrench actuated (order separately). Order extended operating nuts (ENLV) separately. Valve box requires MNA adapters (order separately). To order valve boxes, specify valve centerline to top of valve box (grade).

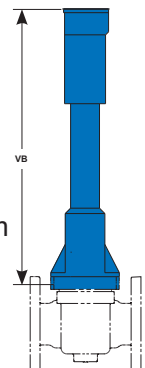

Handwheel and Chainwheel Actuators

Manual gear actuator housings are constructed of high strength metal and feature sintered bronze bearings on each end of the input shaft for durability and performance. The high strength gear provides strength for robust applications and a long service life without maintenance.

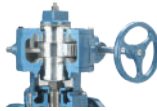

PowerRac Cylinder Actuators

PowerRac double-acting and spring-return actuators feature a proven rack-and-pinion design. PowerRac provides high torque output throughout the full stroke for accurate control.



Spring-Diaphragm Actuators

DeZURIK spring-diaphragm actuators feature all steel, cast iron and stainless steel construction with no aluminum parts to corrode in caustic environments. Diaphragm actuators provide on-off or modulating control with either spring-to-open or spring-to-close operation.

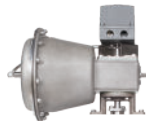

Compak Cylinder Actuators

Compak actuators are a versatile rack-and-pinion design and are available as double-acting or spring-return units. The compact, modular design allows the actuator to be mounted for a low profile assembly.

Electric Motors

DeZURIK offers a variety of electric motor actuators on Eccentric Plug valves. When ordering, please specify valve function, installation location, line fluid, maximum fluid temperature, pipe connection, line size, normal and maximum working pressure, normal and maximum wide open valve flow, and flow range desired if throttling or modulating control.

Dimensions

Material Groups

Group 1	Cast Iron
Group 2	Carbon Steel 2-3" (50-80mm)
Group 3	Stainless Steel, Bronze, Alloys

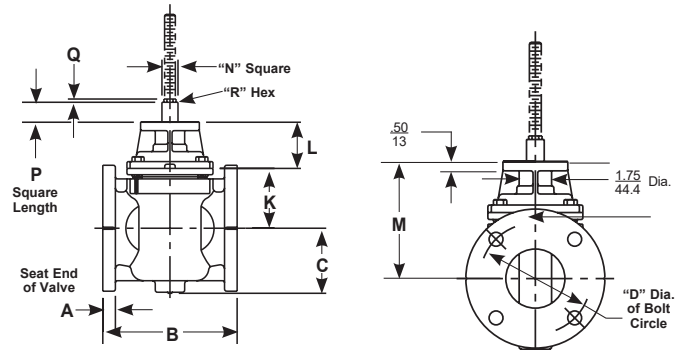

Basic Valve

Valve Size	A	B			C	D**	K	L	M	Square 1	Square 2	Square 3	Square 4	Q	R
		Flanged Material Group 1 & 2*	Flanged Material Group 3	Threaded Material Group 1,2 & 3						N x P	N x P	N x P	N x P		
.5" 15mm	.44 11	4.12 105	4.12 105	3.12 79	1.69 43	2.38 60	1.72 44	2.38 60	4.10 104	.55x.55 14x14	.88x.69 22x17	.50x1.42 13x36	.63x.75 16x19	.21 5	.44 11
.75" 20mm	.44 11	4.12 105	4.12 105	3.12 79	1.69 43	2.75 70	1.72 44	2.38 60	4.10 104	.55x.55 14x14	.88x.69 22x17	.50x1.42 13x36	.63x.75 16x19	.21 5	.44 11
1" 25mm	.44 11	4.12 105	4.12 105	3.12 79	1.69 43	3.12 79	1.72 44	2.38 60	4.10 104	.55x.55 14x14	.88x.69 22x17	.50x1.42 13x36	.63x.75 16x19	.21 5	.44 11
1.25" 32mm	.56 14	4.38 111	4.38 111	4.50 114	2.12 54	3.50 89	2.12 54	2.38 60	4.44 113	.55x.55 14x14	.88x.69 22x17	.50x1.42 13x36	.63x.75 16x19	.21 5	.44 11
1.5" 40mm	.56 14	4.38 111	4.38 111	4.50 114	2.12 54	3.88 98	2.12 54	2.38 60	4.44 113	.55x.55 14x14	.88x.69 22x17	.50x1.42 13x36	.63x.75 16x19	.21 5	.44 11
2" 50mm	.62 16	7.00 178	5.50 140	5.25 133	2.50 64	4.75 121	2.53 64	2.38 60	4.91 125	.55x.55 14x14	.88x1.31 22x33	.50x1.42 13x36	.63x.73 16x19	.21 5	.44 11
2.5" 65mm	.69 18	7.50 191	6.50 165	6.25 159	3.12 79	5.50 140	3.03 77	2.75 70	5.78 147	.67x.54 17x14	.88x1.31 22x33	.63x.74 16x19	.67x.75 17x19	.26 7	.50 13
3" 80mm	.75 19	8.00 203	7.38 187	7.75 197	3.88 98	6.00 152	3.56 90	2.75 70	6.31 160	.67x.54 17x14	.88x1.31 22x33	.63x.74 16x19	.67x.75 17x19	.26 7	.50 13

Inches *Flanged cast iron valves are available in sizes 2, 2.5, and 3" only (50, 65 and 80mm).
 Millimeters **Dimension D is ASME B16.1 Class 125 and ASME B16.5 Class 150.

Dimensions

Lever

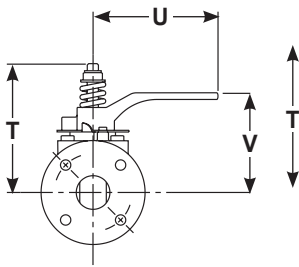

HLA Adapter w/Chain Handle

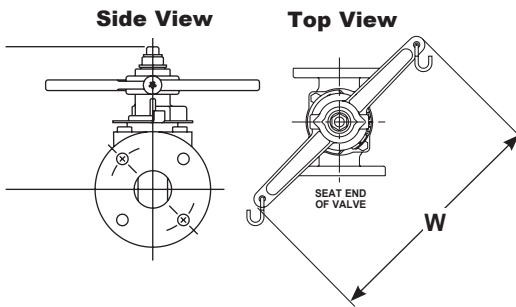

HLA Adapter

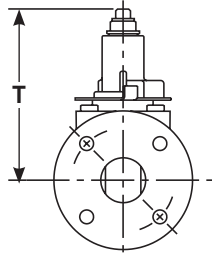

MNA Adapter

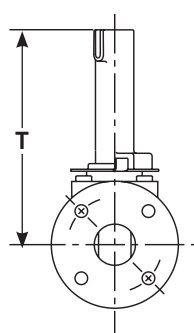

Manual Actuators

Valve Size	T			U	V	W
	Lever	HLA Adapter	MNA Adapter			
.5" 15mm	4.50 114	4.50 114	6.12 155	4.00 102	4.06 103	9.00 229
.75" 20mm	4.50 114	4.50 114	6.12 155	4.00 102	4.06 103	9.00 229
1" 25mm	4.50 114	4.50 114	6.12 155	4.00 102	4.06 103	9.00 229
1.25" 32mm	4.88 124	4.88 124	6.50 165	5.00 127	4.53 115	11.00 279
1.5" 40mm	4.88 124	4.88 124	6.50 165	5.00 127	4.53 115	11.00 279
2" 50mm	6.19 157	6.19 157	7.75 197	6.50 165	5.22 133	14.00 356
2.5" 65mm	7.00 178	7.00 178	9.50 241	7.50 191	5.69 145	14.50 368
3" 80mm	7.75 197	7.75 197	9.50 241	9.00 229	6.38 162	19.00 483

Sales and Service

For information about our worldwide locations, approvals, certifications and local representative:

Web Site: DeZURIK.com E-Mail: info@DeZURIK.com



250 Riverside Ave. N. Sartell, Minnesota 56377 • Phone: 320-259-2000 • Fax: 320-259-2227

DeZURIK, Inc. reserves the right to incorporate our latest design and material changes without notice or obligation. Design features, materials of construction and dimensional data, as described in this bulletin, are provided for your information only and should not be relied upon unless confirmed in writing by DeZURIK, Inc. Certified drawings are available upon request.