

# DeZURIK KSL-SD SLURRY KNIFE GATE VALVES

## Design and Construction

DeZURIK's KSL-SD Slurry Knife Gate Valves are designed for on-off (isolation) service for applications consisting of abrasive, high solids content, wet or dry media. KSL-SD Slurry Knife Gate Valves are ideally suited for applications in the mining, power, and aggregate industries. The KSL-SD valve features a short body design with narrow face-to-face per MSS SP-81.

KSL-SD Knife Gate Valves are available in sizes 2-24" (50-600mm) with larger sizes available on application. Temperature ratings to 177°F (81°C) as standard, and up to 300°F (150°C) with high temperature optional seat materials. Standard pressure rating on 2-16" valves is 150 psi CWP (1030kPa) and 18-24" is 100 psi CWP (690 kPa), with higher pressures available with optional gate materials.

Depending on the application requirements, the cast body is available in Ductile Iron, Carbon Steel and various Stainless Steel or higher alloy materials.



## Packingless Design

The DeZURIK KSL-SD's compression-loaded sleeve design eliminates the need for conventional style packing. In the full open and closed positions, the sleeves seal to both downstream and atmosphere.

## Rugged Stainless Steel Gate

A durable gate resists damage and allows higher pressure drops. Standard gate material options include various stainless steels, heat-treated, and hardened. Other materials available upon request. The gate is finish ground on both sides and edges to ensure long top seal and sleeve life. To extend top seal and sleeve life, optional gate coatings are available that provide a lubrication-infused, non-stick surface that reduces the operating forces of the valve. A strong investment cast gate clip complements the KSL-SD's robust construction.

## Top Seal

The DeZURIK KSL-SD has a top seal to prevent discharge of process media from the top of the valve when the valve is stroked. Gate lubricant can be effectively applied through top seal parts.

## Sleeves

Sleeve material choices are Natural Rubber (NR), Terpolymer of Ethylene Propylene & a Diene (EPDM) or Hydrogenated Acrylonitrile-Butadiene (HNBR).

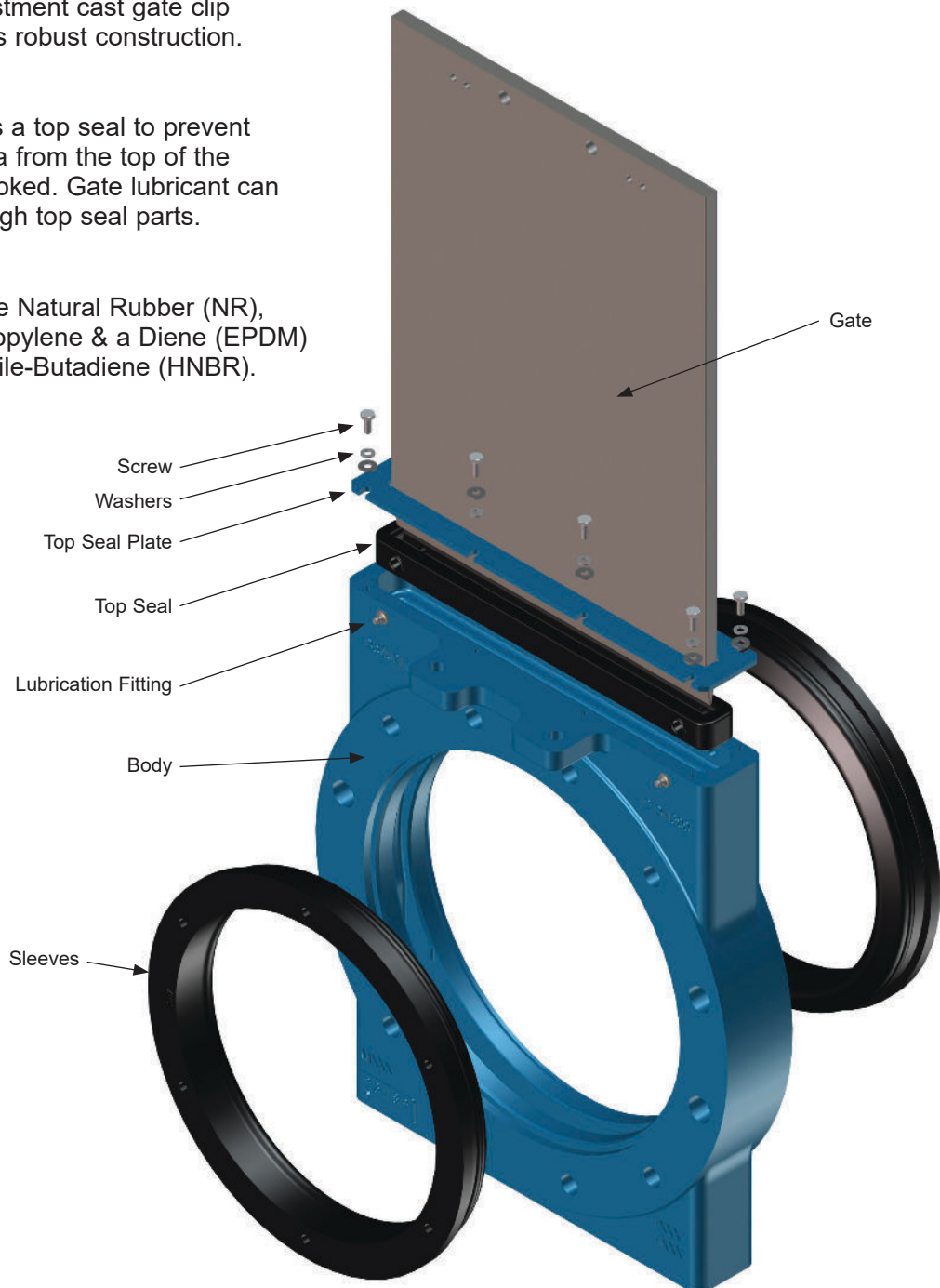

## Features Include:

- Full flanged design with flange drilling per ASME B16.5 Class 150, DIN 10 and DIN 16; ISO 7005-1/ PN10 and 7005-2/PN16; BS 4504/PN10 and BS 4504/PN16; AS 2129 Tables D and E; and SANS 1123-1000 and SANS 1123-1600
- Bi-directional, drip tight shutoff to full pressure rating.
- Field replaceable sleeves with encapsulated supporting ring.
- Valve design allows for easy repairs.
- Full port reduces turbulence and pressure drop across the valve.
- Sleeve compression eliminates cavity where solids can collect.
- Sleeve design eliminates gate and stem packing.
- Sleeve design eliminates the requirement for flange gaskets.
- Straight vertical plane superstructure allows for easy installation of accessories.
- Gate fully retracts out of the flow path in the open position.
- Open / Closed position lock-outs optional.
- Optional gate coatings provide additional abrasion resistance and a non-stick (lubrication infused) surface that reduces actuating forces and extends sleeve life.
- Integral Lifting Lugs standard on sizes 4" (100mm) and larger.
- Flushing drain plates available.

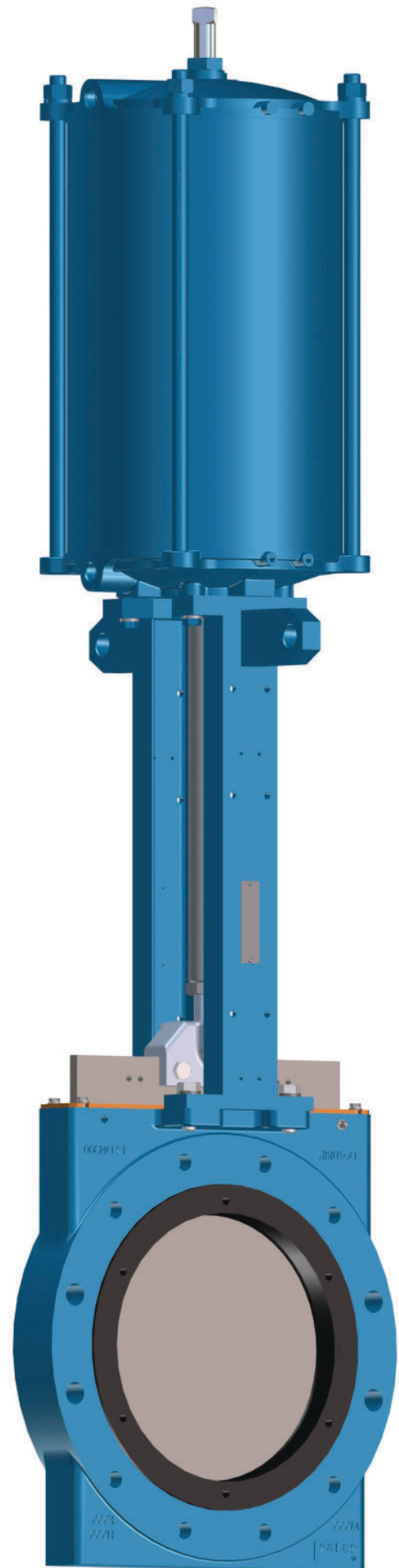

## Open/Closed Position Lock-outs

The DeZURIK KSL-SD is available with optional open and closed position lock-outs. The lock-outs are designed to withstand the maximum operating forces of the actuator supplied on the valve.

## Stainless Steel Stem

All valves are furnished with a stainless steel stem that provides extra corrosion resistance, easy operation, and a longer cycle life. On manually operated valves the stem has single lead threads to minimize wear and reduce the operating torque requirements of the valve.

## Choice of Actuators

The DeZURIK KSL-SD Slurry Knife Gate Valve is offered with a choice of handwheel, chainwheel, bevel gear, pneumatic or hydraulic cylinder, or electric motor actuators. Custom engineered Hydraulic Power Units are also available.

## Corrosion Resistant Yoke Sleeve

A bronze yoke sleeve on manually operated valves provides corrosion resistance and assures easy operation. A grease fitting is provided to lubricate the stem thread and yoke sleeve.

## Heavy-Duty Vertical Plane Superstructure

The standard actuator superstructure is available in carbon steel or stainless steel and is designed to stand up under the most difficult operating conditions. The vertical plane design allows for easy installation of accessories. For valves mounted in horizontal installations, strengthened superstructures are available.

## Integral Lifting Lugs

On sizes 4" and larger, integral lifting lugs are designed to support the full weight of the valve.

## Accessories

A wide variety of accessories are available including handwheel extensions, floor stands, stem covers, gate guard and various cylinder actuator accessories such as filter regulators, speed controls and position indicating switches for customizing the valve/actuator package to meet specific application requirements.



# Materials of Construction

Item	Description	Material
A1	Body	Ductile Iron, ASTM A395, Grade 65-45-15
		Carbon Steel, ASTM A36
		316 Stainless Steel, ASTM A240 Type 316
		2205 Duplex Stainless Steel, ASTM A240/A276/789, Type 2205 Duplex Stainless Steel
A2	Gate	316 Stainless Steel, ASTM A240 Type 316
		17-4 PH Stainless Steel H900 Heat Treated, ASTM A564
		2205 Duplex Stainless Steel, ASTM A276
		316 Stainless Steel, ASTM A240 Type 316 with a hardened nickel based non-stick coating
		17-4 PH Stainless Steel H900 Heat Treated, ASTM A564 with a hardened nickel based non-stick coating
A3	Sleeve	2205 Duplex Stainless Steel, ASTM A276 with a hardened nickel based non-stick coating
		NR - Natural Rubber to 177°F (80°C)
		HNBR - Hydrogenated Acrylonitrile Butadiene to 300°F (150°C)
A4	Top Seal	EPDM - Terpolymer of Ethylene, Propylene & a Diene to 250°F (120°C)
		HNBR - Hydrogenated Acrylonitrile Butadiene to 300°F (150°C)
A5	Top Seal Plate	Carbon Steel, ASTM A36
A6	Washer	Carbon Steel, Zinc Plated
A7	Lock Washer	Carbon Steel, Zinc Plated
A8	Screw	Carbon Steel, Zinc Plated
A9	Grease Fitting	Stainless Steel
A10	Drain Gasket	Aramid/Inorganic Fiber with NBR Rubber Binder, ASTM F104, Type F712120, A9B3E12K5L151M6 (Optional)
A11	Drain Plate	Carbon Steel, A36 (Optional)
A12	Washer	Carbon Steel, Zinc Plated
A13	Lock Washer	Carbon Steel, Zinc Plated
A14	Screw	Carbon Steel, Zinc Plated

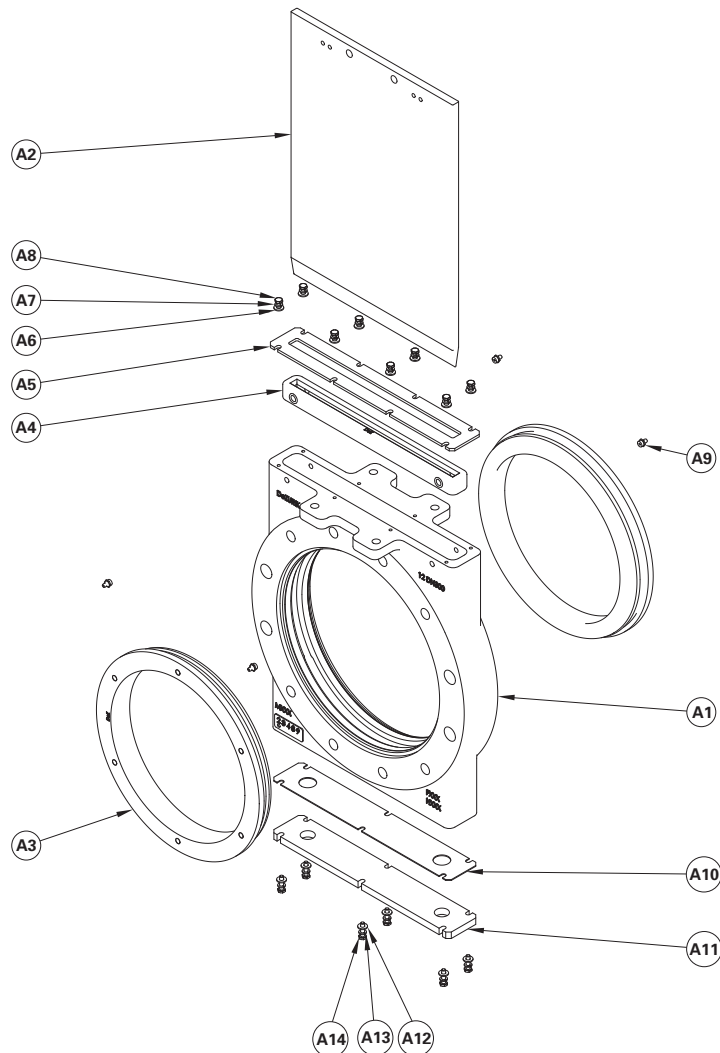

# Valve Selection

## Applicable Standards

DeZURIK KSL-SD Knife Gate Valves are designed and/or tested to meet the following standards:	
ASME B16.5/150	ASME B16.5 Class 150 Flange Drilling
DIN 10	Metric 10 bar Flange Drilling
ISO 7500/PIN10	PN10 Flange Drilling
DIN 16	Metric 16 bar Flange Drilling
ISO 7500/PN16	PN16 Flange Drilling
AS2129 Table D	Australian Table D Flange Drilling
AS2129 Table E	Australian Table E Flange Drilling
SANS 1123-1000	South African 1000 kPa Flange Drilling
SANS 1123-1600	South African 1600 kPa Flange Drilling
MSS SP-81	Face-to-face Dimensions Sleeves act as flange gaskets and increase the installed face-to-face dimension by 1/4 inch

## Shut-Off Capabilities

2-24" (50-600mm)	Bi-Directional Driptight
------------------	--------------------------

NOTE: Leakage expected during actuation

## Pressure Ratings

2-16" (50-400mm)	150 psi C.W.P. (1030 kPa)
18-24" (450-600mm)	100 psi C.W.P. (690 kPa)

Higher pressure ratings available on application.

## Valve & Actuator Weights

Valve Size	Basic Valve	With Handwheel	With Chainwheel	With Bevel Gear Handwheel	With Bevel Gear Chainwheel	Pneumatic Cylinder	Hydraulic Cylinder
2" 50mm	22 10	52 24	66 30	73 33	80 36	43 20	40 18
3" 80mm	29 13	59 27	73 33	80 36	87 40	69 31	47 21
4" 100mm	34 15	67 30	81 37	92 42	97 44	80 36	56 25
6" 150mm	50 23	97 44	132 60	111 50	119 54	112 51	76 35
8" 200mm	85 39	149 68	184 84	165 75	176 80	170 77	129 59
10" 250mm	120 55	193 88	226 103	215 98	241 110	241 110	187 85
12" 300mm	178 81	N/A	N/A	272 124	299 136	329 150	245 111
14" 350mm	212 96	N/A	N/A	317 144	346 157	374 170	299 136
16" 400mm	298 135	N/A	N/A	404 184	433 197	488 222	385 175
18" 450mm	334 152	N/A	N/A	494 225	520 236	533 242	425 193
20" 500mm	498 226	N/A	N/A	679 309	705 320	1131 514	639 290
24" 600mm	693 315	N/A	N/A	875 398	902 410	1291 587	838 381

Pounds  
Kilograms

## Flow Parameters

Valve Size	Cv* Kv* 100% Open	K Factor** (resistance)	Port Area (in <sup>2</sup> /cm <sup>2</sup> )
2" 50mm	270 240	0.16	2.9 18
3" 80mm	630 550	0.16	6.6 43
4" 100mm	1140 990	0.16	12.0 77
6" 150mm	2580 2230	0.16	27.1 175
8" 200mm	4640 4010	0.16	48.7 314
10" 250mm	7300 6310	0.16	76.6 494
12" 300mm	10440 9030	0.16	109.6 707
14" 350mm	12760 11040	0.16	134.0 865
16" 400mm	16970 14680	0.16	178.2 1150
18" 450mm	21780 18840	0.16	228.7 1475
20" 500mm	27180 23520	0.16	285.4 1841
24" 600mm	39790 34420	0.16	417.7 2695

\*Cv = Flow in GPM of water at 1 psi pressure drop.  
Kv = Flow in m<sup>3</sup>/hr. of water at 100 kPa pressure drop.  
\*\* K = The resistance coefficient of the valve. The constant (K) can be used to determine the equivalent length of pipe.

$L = \frac{K \times D}{f}$  Where  
L = Equivalent length of pipe in feet  
K = Resistance coefficient  
D = Pipe diameter in feet  
f = Friction factor, related to type of pipe

# Ordering

To order, simply complete the valve order code from information shown. An ordering example is shown for your reference.

## Valve Style

Give valve style code as follows:

KSL = Slurry Knife Gate Valve

## Valve Size

Give valve size code as follows:

2	=	2"	(50mm)	12	=	12"	(300mm)
3	=	3"	(80mm)	14	=	14"	(350mm)
4	=	4"	(100mm)	16	=	16"	(400mm)
6	=	6"	(150mm)	18	=	18"	(450mm)
8	=	8"	(200mm)	20	=	20"	(500mm)
10	=	10"	(250mm)	24	=	24"	(600mm)

## Body Style

Give body style code as follows:

SD = Short Body Style

## End Connection

Give end connection code as follows:

F1 = Flanged ASME 150  
F110 = ISO 7005/PN10 (DIN10) Drilling  
F116 = ISO 7005/PN16 (DIN16) Drilling  
F1DA = AS2129 Table D Drilling  
F1EA = AS2129 Table E Drilling  
F1S10 = SANS 1123-1000 Drilling  
F1S16 = SANS 1123-1600 Drilling

## Body Material

Give body material code as follows:

DI = Ductile Iron  
CS = Carbon Steel  
S2 = 316 Stainless Steel  
S10 = 2205 Duplex Stainless Steel

## Top Seal

Give top seal code as follows:

EPDM = Terpolymer of Ethylene, Propylene & A Diene, to 250° F (120° C)  
HNBR = Hydrogenated Acrylonitrile-Butadiene to 300°F (150°C)

## Gate

Give gate material code as follows:

S2 = 316 Stainless Steel  
S5 = 17-4PH Stainless Steel H900 Heat Treated  
S10 = 2205 Duplex Stainless Steel  
S2C = 316 Stainless Steel with a hardened nickel-based, non-stick coating  
S5C = 17-4PH Stainless Steel H900 Heat Treated with a hardened nickel-based, non-stick coating  
S10C = 2205 Duplex Stainless Steel with a hardened nickel-based, non-stick coating

## Sleeve Material

Give sleeve material code as follows:

NR = Natural Rubber to 177° F (80° C). Use with EPDM top seal.  
EPDM = Terpolymer of Ethylene, Propylene & A Diene, to 250° F (120° C). Use with EPDM top seal.  
HNBR = Hydrogenated Acrylonitrile-Butadiene, to 300° F (150° C). Use with HNBR top seal.

## Options

Give options code as follows:

— = Paint Options (Contact DeZURIK)  
CRT = Certified Physical and Chemical Test Report (body & gate only)  
CMC = Certificate of Material Conformance  
DP = Drain Plate  
DTR = DeZURIK Standard Certified Production Hydrostatic Sleeve and Seat Test Report

## Ordering Example

KSL,6,SD,F1,DI,EPDM,S2-NR,DP\*actuator

# Manual Actuators

## Handwheel and Chainwheel Actuators

All 2-10" (50-250mm) valves can be furnished with handwheel or chainwheel actuators. To order, add the appropriate order code to the basic valve order code. Order chain for chainwheel actuators as a separate item.

### Handwheel Actuator

Valve Size	Order Code	Maximum Pressure Differential (psi/kPa)
	Carbon Steel (CS) Yoke	
2" 50mm	MN-HD12-CS	150 1030
3" 80mm	MN-HD12-CS	150 1030
4" 100mm	MN-HD12-CS	150 1030
6" 150mm	MN-HD20-CS	150 1030
8" 200mm	MN-HD20-CS	150 1030
10" 250mm	MN-HD20-CS	150 1030

### Chainwheel Actuator

Valve Size	Order Code	Maximum Pressure Differential (psi/kPa)
	Carbon Steel (CS) Yoke	
2" 50mm	MN-CW12-CS	150 1030
3" 80mm	MN-CW12-CS	150 1030
4" 100mm	MN-CW12-CS	150 1030
6" 150mm	MN-CW20-CS	150 1030
8" 200mm	MN-CW20-CS	150 1030
10" 250mm	MN-CW20-CS	150 1030

NOTE: The limiting factor in actuator selection is the lowest pressure rating of the valve or actuator.

#### Ordering Example

KSL,6,SD,F1,DI,EPDM,S2-NR,DP\*MN-HD20-CS

## Bevel Gear Actuators

Bevel gear actuators are available on 2-24" (50-600mm) valves with handwheel or chainwheel actuators. Bevel gear actuators provide vertical mounting of the handwheel or chainwheel, or can be used where space limitations prohibit the use of a standard handwheel or chainwheel. A mechanical advantage makes large valve operation easier and faster.

### Bevel Gear Handwheel Actuator

Valve Size	Order Code	Maximum Pressure Differential (psi/kPa)
	Carbon Steel (CS) Yoke	
2" 50mm	MNB-HD12-CS	150 1030
3" 80mm	MNB-HD12-CS	150 1030
4" 100mm	MNB-HD12-CS	150 1030
6" 150mm	MNB-HD12-CS	150 1030
8" 200mm	MNB-HD12-CS	150 1030
10" 250mm	MNB-HD24-CS	150 1030
12" 300mm	MNB-HD24-CS	150 1030
14" 350mm	MNB-HD24-CS	150 1030
16" 400mm	MNB-HD24-CS	150 1030
18" 450mm	MNB-HD24-CS	100 690
20" 500mm	MNB-HD24-CS	100 690
24" 600mm	MNB-HD24-CS	100 690

### Bevel Gear Chainwheel Actuator

Valve Size	Order Code	Maximum Pressure Differential (psi/kPa)
	Carbon Steel (CS) Yoke	
2" 50mm	MNB-CW12-CS	150 1030
3" 80mm	MNB-CW12-CS	150 1030
4" 100mm	MNB-CW12-CS	150 1030
6" 150mm	MNB-CW12-CS	150 1030
8" 200mm	MNB-CW12-CS	150 1030
10" 250mm	MNB-CW20-CS	150 1030
12" 300mm	MNB-CW20-CS	150 1030
14" 350mm	MNB-CW20-CS	150 1030
16" 400mm	MNB-CW20-CS	150 1030
18" 450mm	MNB-CW20-CS	100 690
20" 500mm	MNB-CW20-CS	100 690
24" 600mm	MNB-CW20-CS	100 690

NOTE: For alternate mounting of bevel gear actuators, add -90 after the actuator code and as second line information on the order. The limiting factor in actuator selection is the lowest pressure rating of the valve or actuator.

#### Ordering Example

KSL,6,SD,F1,DI,EPDM,S2-NR,DP\*MNB-HD12-CS



# Manual Actuator Accessories

## Chain for Chainwheel Actuators

Order as a separate item by giving the correct code and specify required length of chain as second line information. One closing link is supplied with the chainwheel actuator.

Order Code	Description
ACC*CN102	Steel, Zinc Plated 3/16
ACC*CN103	Galvanized 3/16
ACC*CN106	316 Stainless Steel 3/16

### Ordering Example

ACC\*CN102

Chain 12 feet long (366cm)

## Lockout Device

Available on sizes 2-10" (50-250 mm) valves with handwheel and sizes 2-24" (50-600 mm) with bevel gear handwheel actuated valves. To order, add a comma and the order code "LK" after the actuator code.

### Ordering Example

KSL,6,SD,F1,DI,EPDM,S2-NR,DP\*MNB-HD12-CS,LK

## Gate Guards

Available on sizes 2-24", Gate Guards protect the gate from the external environment. To order, add a comma and the order code "GG" after the actuator code.

### Ordering Example

KSL,10,SD,F1,DI,EPDM,S2-EPDM\*MN-HD20-CS,GG

# Pneumatic Cylinder Actuators

DeZURIK double-acting pneumatic cylinder actuators are available for on/off service. Supply pressure is 60 or 80 psi (410 or 550 kPa). To order, add the proper code from the table to the valve order code.

## 60 psi (410 kPa) Air Supply

Valve Size	Order Code	Maximum Pressure Differential (psi/kPa)
	Carbon Steel (CS) Yoke	
2" 50mm	CY-PC4-CS	150 1030
3" 80mm	CY-PC6-CS	150 1030
4" 100mm	CY-PC6-CS	150 1030
6" 150mm	CY-PC8-CS	150 1030
8" 200mm	CY-PC8-CS	150 1030
10" 250mm	CY-PC10-CS	150 1030
12" 300mm	CY-PC12-CS	150 1030
14" 350mm	CY-PC12-CS	150 1030
16" 400mm	CY-PC14-CS	100 690
18" 450mm	CY-PC14-CS	75 520
20" 500mm	CY-PC16-CS	75 520
24" 600mm	CY-PC16-CS	75 520

NOTE: The limiting factor in actuator selection is the lowest pressure rating of the valve or actuator.

## 80 psi (550 kPa) Air Supply

Valve Size	Order Code	Maximum Pressure Differential (psi/kPa)
	Carbon Steel (CS) Yoke	
2" 50mm	CY-PC4-CS	150 1030
3" 80mm	CY-PC6-CS	150 1030
4" 100mm	CY-PC6-CS	150 1030
6" 150mm	CY-PC8-CS	150 1030
8" 200mm	CY-PC8-CS	150 1030
10" 250mm	CY-PC10-CS	150 1030
12" 300mm	CY-PC12-CS	150 1030
14" 350mm	CY-PC12-CS	150 1030
16" 400mm	CY-PC14-CS	150 1030
18" 450mm	CY-PC14-CS	100 690
20" 500mm	CY-PC16-CS	100 690
24" 600mm	CY-PC16-CS	100 690

# Cylinder Actuator Accessories

## Air Filter Regulator

The DeZURIK Air Filter Regulator is designed to provide clean, accurate air pressure to pneumatic cylinder actuators.

## Four-Way Solenoid Valve

Solenoid valves may be ordered mounted and piped as part of a complete valve and pneumatic cylinder actuator assembly or as a separate item.

## Speed Control Valves

Speed Control Valves are available for controlling valve opening or closing speed with pneumatic cylinder actuators.

## Position Indicating Switches

Mechanical or Proximity Position Indicating Switches are available for use on double-acting pneumatic cylinder actuators. One switch can be set to indicate open or closed position. Two switches will automatically be set to indicate full open and full closed positions.

## Stem Cover Boot

To protect valve stem from environmental debris, the Stem Cover Boot may be ordered as part of a complete valve and actuator assembly.

### Ordering Example:

KSL,6,SD,F1,DI,EPDM,S2-NR,DP\*CY-PC8-CS,SCB

## Lockout Device

Available on all sizes for cylinder actuated valves. To order, add a comma and the order code "LK" after the actuator code.

### Ordering Example:

KSL,6,SD,F1,DI,EPDM,S2-NR,DP\*CY-PC8-CS,LK

## Corrosion Resistant Cylinder

Includes epoxy coated head and endcaps. Tie rods are stainless steel. To order, add code "CR" after the actuator code.

### Ordering Example:

KSL,10,SD,F1,DI,EPDM,S2-EPDM\*CY-PC10-CS-CR

# Cylinder Actuator Accessories

## 303 Stainless Steel Braided Hose and 316 Stainless Steel Fittings

Available on all sizes of cylinder actuators. To order, add code "SFB" after the actuator code.

### Ordering Example

KSL,10,SD,F1,DI,EPDM,S2-EPDM\*CY-PC10-CS-SFB

## 316 Stainless Steel Tubing and 316 Stainless Steel Two-Ferrule Fittings

Available on all sizes of cylinder actuators. To order, add code "SF2" after the actuator code.

### Ordering Example

KSL,10,SD,F1,DI,EPDM,S2-EPDM\*CY-PC10-CS-SF2

# Electric Motor Actuators

DeZURIK Knife Gate Valves can be furnished with electric motor actuators including Limitorque, Auma, Rotork, E.I.M. and others.

When ordering electric motor actuators, specify valve order code, shutoff pressure, service conditions (flowing media); speed of operation; NEMA rating (4, 7, as per specification requirements, submersible, etc.); electrical characteristics (voltage and phase); actuator accessories and controls.

# Hydraulic Cylinder Actuators

Double-acting hydraulic cylinders for on/off services. All actuators are sized to the full pressure rating of the valve. Actuator sizing is for slurries and liquids; contact DeZURIK for sizing on dry materials applications.

## Actuator Sizing

Valve Size	Order Code	Supply	Maximum Pressure Differential (psi/kPa)
	Carbon Steel (CS) Yoke	Nominal Pressure (psi/kPa)	
2" 50mm	CY-HC1.5-CS	1200	150
		8280	1030
3" 80mm	CY-HC1.5-CS	1200	150
		8280	1030
4" 100mm	CY-HC1.5-CS	1200	150
		8280	1030
6" 150mm	CY-HC2-CS	1200	150
		8280	1030
8" 200mm	CY-HC2-CS	1200	150
		8280	1030
10" 250mm	CY-HC3.25-CS	800	150
		5520	1030
12" 300mm	CY-HC3.25-CS	800	150
		5520	1030
14" 350mm	CY-HC4-CS	650	150
		4485	1030
16" 400mm	CY-HC4-CS	650	150
		4485	1030
18" 450mm	CY-HC4-CS	650	100
		4485	690
20" 500mm	CY-HC5-CS	650	100
		4485	690
24" 600mm	CY-HC5-CS	650	100
		4485	690

The maximum hydraulic pressure rating for hydraulic cylinders by size is as follows:

HC1.5	=	2000psi (13790 kPa)
HC2	=	2000psi (13790 kPa)
HC3.25	=	1000psi (6900 kPa)
HC4	=	800psi (5520 kPa)
HC5	=	950psi (6550 kPa)

# Dimensions

## Handwheel & Chainwheel

Valve Size	Dimensions				
	G1	G2	H	K	L
2"	2.31	2.13	3.44	23.00	12.00
50mm	59	54	87	584	305
3"	2.44	2.25	4.06	24.75	12.00
80mm	62	57	103	629	305
4"	2.44	2.25	4.81	28.38	12.00
100mm	62	57	122	721	305
6"	2.75	2.50	5.81	33.63	20.00
150mm	70	64	148	854	508
8"	3.28	3.00	6.94	41.81	20.00
200mm	83	76	176	1062	508
10"	3.31	3.00	8.31	49.56	20.00
250mm	84	76	211	1259	508

Inches  
Millimeters

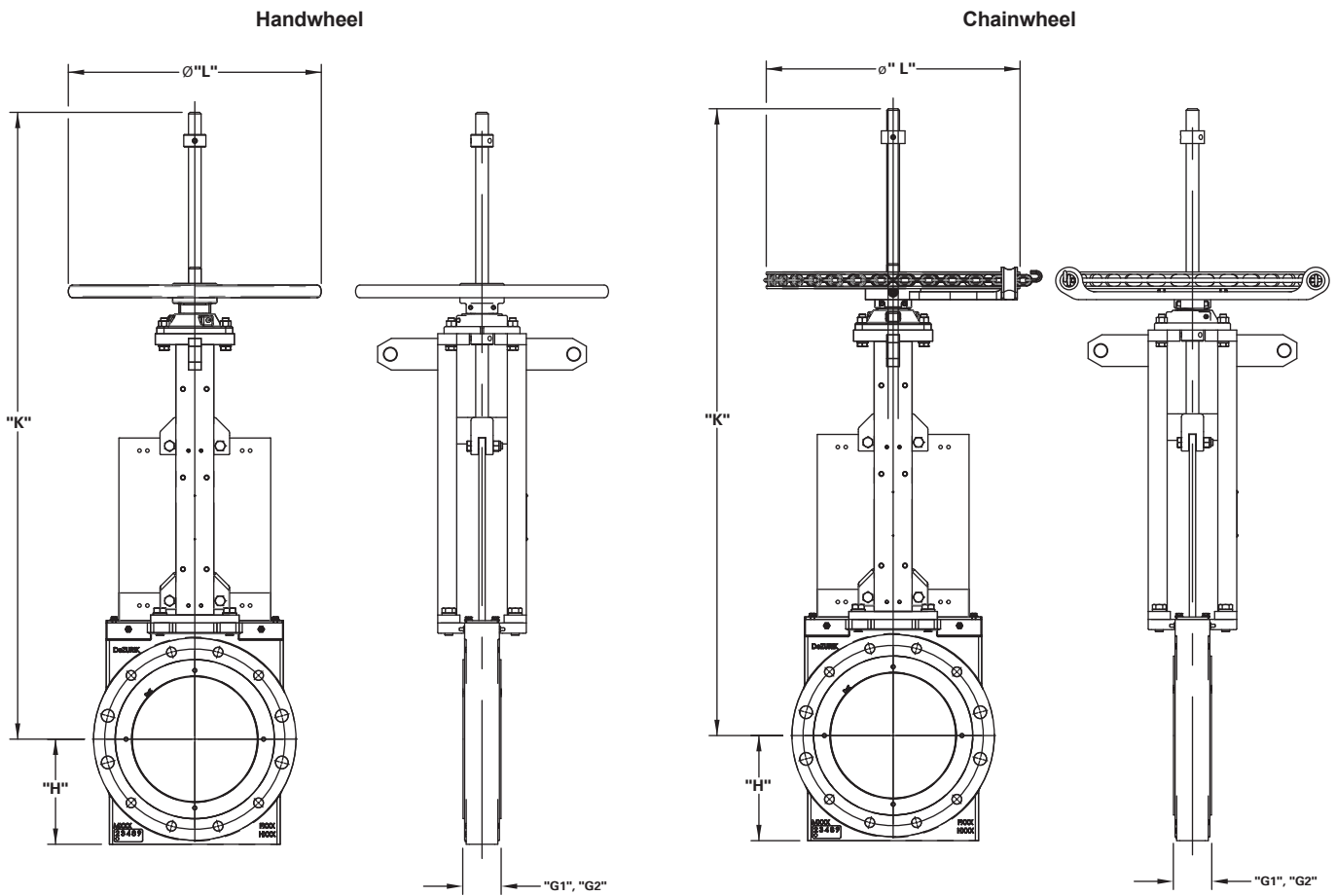

NOTE: "G1" is the minimum dimension required for installation. "G2" is the installed dimension after seat compression. Flange gaskets are not used.

# Dimensions

## Bevel Gear Handwheel and Chainwheel

Valve Size	Dimensions							
	G1	G2	H	K	L		P	
					Handwheel	Chainwheel	Handwheel	Chainwheel
2" 50mm	2.31 59	2.13 54	3.44 87	24.88 632	12.00 305	12.00 305	13.63 346	13.12 333
3" 80mm	2.44 62	2.25 57	4.06 103	25.51 648	12.00 305	12.00 305	14.00 356	13.50 343
4" 100mm	2.44 62	2.25 57	4.81 122	32.01 813	12.00 305	12.00 305	14.62 371	14.12 359
6" 150mm	2.75 70	2.50 64	5.81 148	34.82 884	12.00 305	12.00 305	15.62 397	15.12 384
8" 200mm	3.28 83	3.00 76	6.94 176	42.63 1083	12.00 305	12.00 305	16.87 428	23.43 595
10" 250mm	3.31 84	3.00 76	8.31 211	51.63 1311	24.00 610	20.00 508	24.75 629	24.65 626
12" 300mm	3.56 91	3.25 83	9.81 249	55.01 1397	24.00 610	20.00 508	26.25 667	26.15 664
14" 350mm	3.56 91	3.25 83	10.81 275	60.38 1534	24.00 610	20.00 508	27.25 692	27.15 690
16" 400mm	4.13 105	3.75 95	12.00 305	65.70 1669	24.00 610	20.00 508	28.50 724	28.40 721
18" 450mm	4.13 105	3.75 95	12.88 327	73.51 1867	24.00 610	20.00 508	31.98 812	31.91 811
20" 500mm	5.19 132	4.75 121	14.25 362	77.70 1974	24.00 610	20.00 508	33.35 847	33.29 846
24" 600mm	5.19 132	4.75 121	16.38 416	96.45 2450	24.00 610	20.00 508	35.54 903	36.48 927

Inches  
Millimeters

Bevel Gear Handwheel

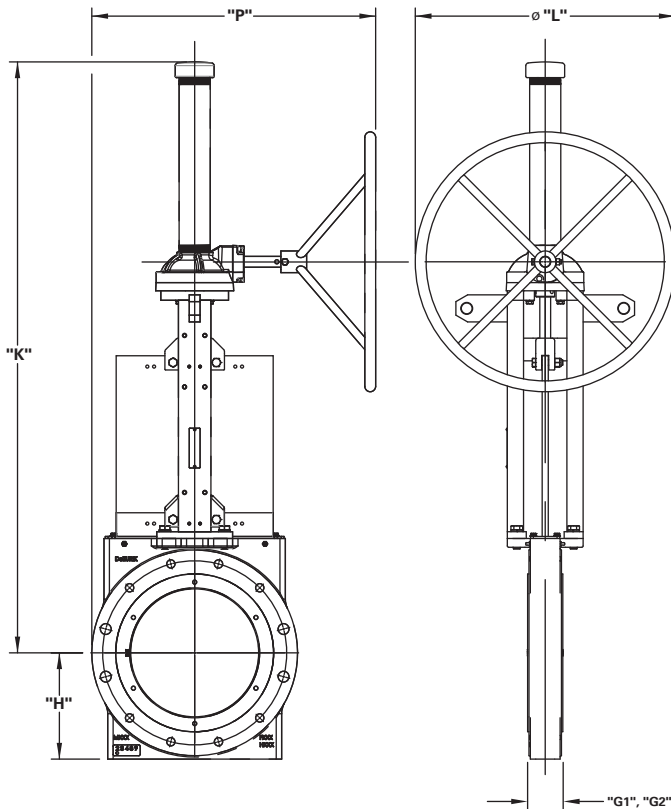

Bevel Gear Chainwheel

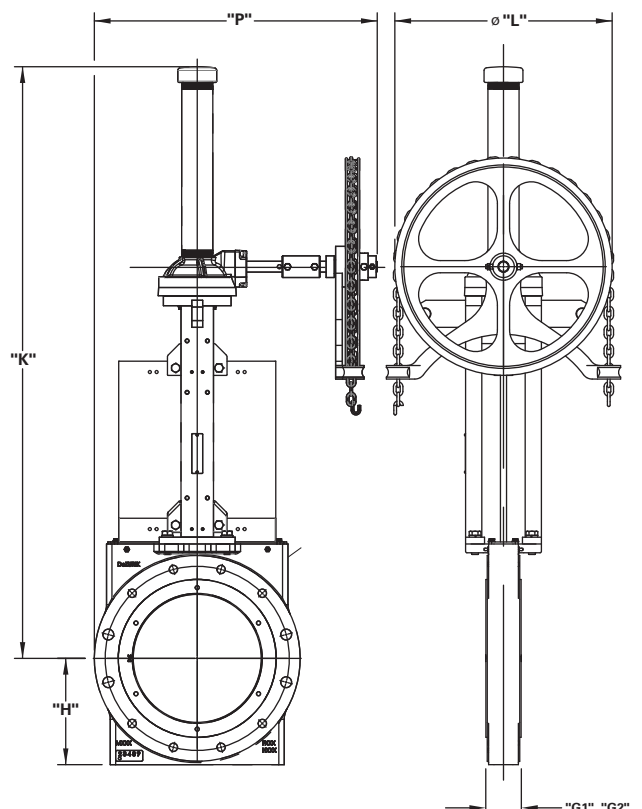

NOTE: "G1" is the minimum dimension required for installation. "G2" is the installed dimension after seat compression. Flange gaskets are not used.

# Dimensions

## Pneumatic Cylinder

Valve Size	Dimensions				
	G1	G2	H	K	P
2"	2.31	2.13	3.44	25.74	6.00
50mm	59	54	87	654	152
3"	2.44	2.25	4.06	27.83	7.00
80mm	62	57	103	707	178
4"	2.44	2.25	4.81	32.08	11.00
100mm	62	57	122	815	279
6"	2.75	2.50	5.81	37.77	11.00
150mm	70	64	148	959	279
8"	3.28	3.00	6.94	47.31	12.00
200mm	83	76	176	1202	305
10"	3.31	3.00	8.31	58.31	16.50
250mm	84	76	211	1481	419
12"	3.56	3.25	9.81	59.84	16.50
300mm	91	83	249	1520	419
14"	3.56	3.25	10.81	69.12	16.50
350mm	91	83	275	1756	419
16"	4.13	3.75	12.00	69.71	17.50
400mm	105	95	305	1771	445
18"	4.13	3.75	12.88	78.40	17.50
450mm	105	95	327	1991	445
20"	5.19	4.75	14.25	80.00	20.25
500mm	132	121	362	2032	514
24"	5.19	4.75	16.38	91.38	20.25
600mm	132	121	416	2321	514

Inches  
Millimeters

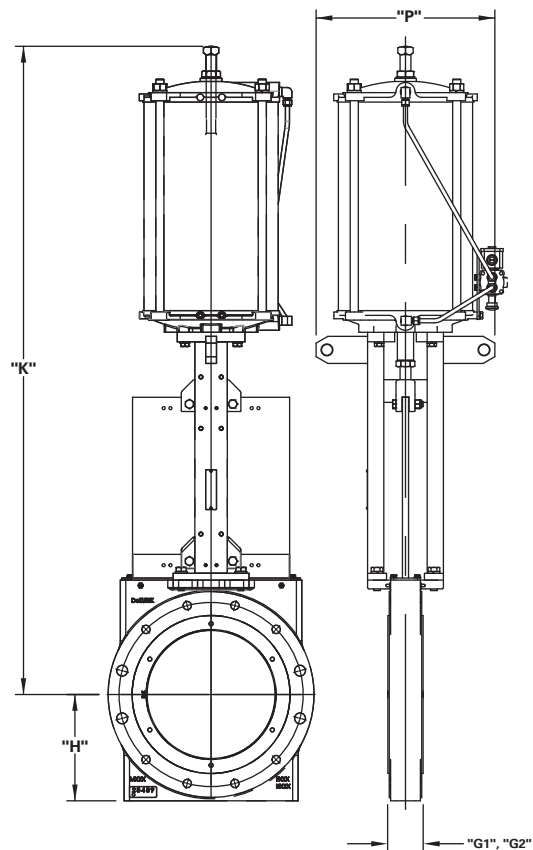

## Hydraulic Cylinder

Valve Size	Dimensions				
	G1	G2	H	K	P
2"	2.31	2.13	3.44	23.44	6.00
50mm	59	54	87	595	152
3"	2.44	2.25	4.06	25.19	6.00
80mm	62	57	103	640	152
4"	2.44	2.25	4.81	28.94	11.00
100mm	62	57	122	735	279
6"	2.75	2.50	5.81	33.75	11.00
150mm	70	64	148	857	279
8"	3.28	3.00	6.94	41.85	12.00
200mm	83	76	176	1063	305
10"	3.31	3.00	8.31	50.19	16.50
250mm	84	76	211	1275	419
12"	3.56	3.25	9.81	53.81	16.50
300mm	91	83	249	1367	419
14"	3.56	3.25	10.81	60.44	16.50
350mm	91	83	275	1535	419
16"	4.13	3.75	12.00	64.63	17.50
400mm	105	95	305	1642	445
18"	4.13	3.75	12.88	71.32	17.50
450mm	105	95	327	1812	445
20"	5.19	4.75	14.25	75.51	20.25
500mm	132	121	362	1918	514
24"	5.19	4.75	16.38	89.88	20.25
600mm	132	121	416	2283	514

Inches  
Millimeters

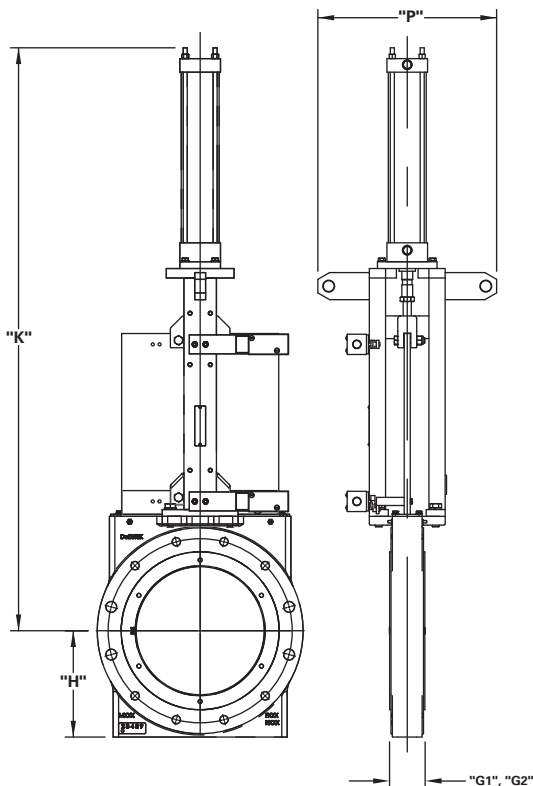

NOTE: "G1" is the minimum dimension required for installation. "G2" is the installed dimension after seat compression. Flange gaskets are not used.

## Sales and Service

For information about our worldwide locations, approvals, certifications and local representative:

**Web Site:** [DeZURIK.com](http://DeZURIK.com)    **E-Mail:** [info@DeZURIK.com](mailto:info@DeZURIK.com)



250 Riverside Ave. N. Sartell, Minnesota 56377 • Phone: 320-259-2000 • Fax: 320-259-2227

*DeZURIK, Inc. reserves the right to incorporate our latest design and material changes without notice or obligation. Design features, materials of construction and dimensional data, as described in this bulletin, are provided for your information only and should not be relied upon unless confirmed in writing by DeZURIK, Inc. Certified drawings are available upon request.*