

HILTON FIXED CONE VALVES

Purpose of Fixed Cone Valves

- Designed for continuous flow control with free discharge.
- Commonly used on reservoirs for water level control and turbine by-pass.

Design Characteristics

- Robust construction, designed for years of trouble free service.
- Unique rib design to reduce vibration.
- Available baffled hood design provides ~ 90% energy reduction compared to 20%-40% reduction for an un-baffled hood (based on testing performed at the Utah State University Water Research Laboratory)
- Metal-to-metal or resilient seat designs available. Optional Nitronic 60 seat rings for increased wear resistance.
- Operates smoothly from zero to 100% capacity without cavitation.
- Flow discharge coefficient between 0.80-0.85.
- Body and sleeve seat rings are designed to be replaceable with the valve in place.

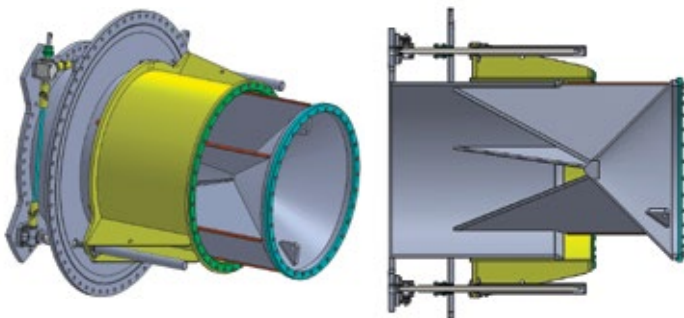

Typical Fixed Cone Valve Design



12" Fixed Cone Valve With Baffled Hood
Used For Performance Testing At Utah State
University Water Research Laboratory

Material & Actuation Options

- Typically provided in carbon steel with stainless steel in critical components.
- Epoxy coating options available.
- Can be provided in all stainless or other weldable alloys at the user's request.
- Actuation options include manual, electric and hydraulic.
- Hydraulic power units available.

Test Standards

- HILTON Standard or to user's specifications.

Flow Characteristics

FLOW (CALCULATED) vs. HEAD by % OPEN (24" HILTON FIXED CONE VALVE)

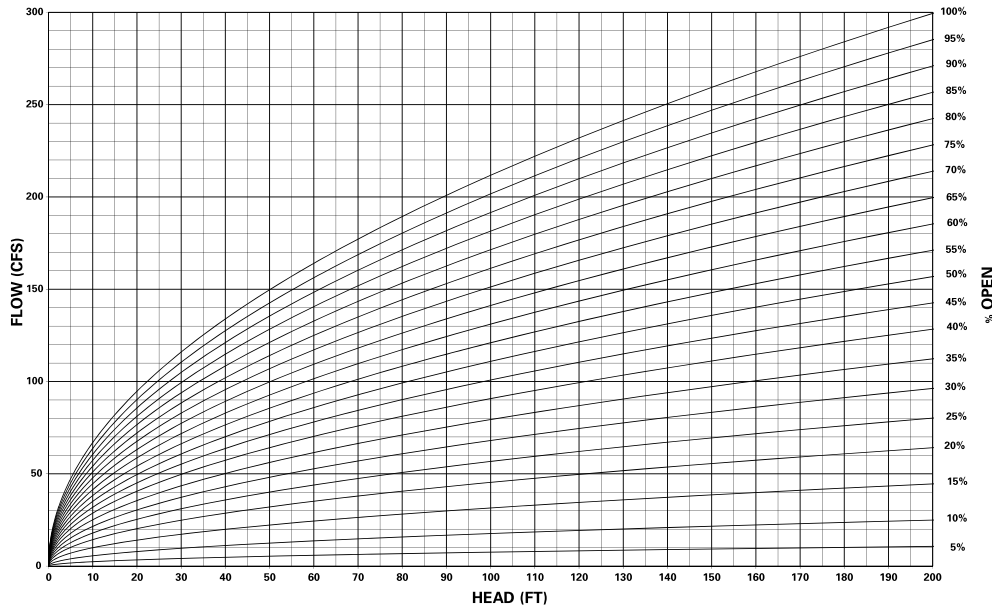

Other Hilton Valves for Hydro Applications

- Jet Flow Gate Valves
- Throttling Knife Gate Valves
- Knife Gate Guard Valves
- Slide Gate Valves

Hilton Offers Decades of Experience In Free Discharge Applications

Hilton Valves have been successfully applied in free discharge applications in the hydropower industry since 1975. This extensive experience with hydro applications enables Hilton application engineers to provide recommendations and assist with specifications for consulting engineers and utilities. Hilton Jet Flow Gates utilize heavy duty construction and are based on the original US Bureau of Reclamation designs. In addition, Hilton pioneered the use of Throttling Knife Gate Valves as another alternative to Jet Flow Gates and Fixed Cone Valves in appropriate applications.



60" Fixed Cone Valve Body, Fabricated from 304 Stainless Steel & Nitronic 60

Sales and Service

For information about our worldwide locations, approvals, certifications and local representative:

Web Site: www.dezurik.com E-Mail: info@dezurik.com



250 Riverside Ave. N. Sartell, Minnesota 56377 • Phone: 320-259-2000 • Fax: 320-259-2227

DeZURIK, Inc. reserves the right to incorporate our latest design and material changes without notice or obligation. Design features, materials of construction and dimensional data, as described in this bulletin, are provided for your information only and should not be relied upon unless confirmed in writing by DeZURIK, Inc. Certified drawings are available upon request.